

PM Group S.p.A.
Via G. Verdi, 22
41018 San Cesario sul Panaro - Modena (Italy)
tel. +39 059 936811
fax. +39 059 936800
e-mail: sparepartsdept@pm-group.eu
servicedept@pm-group.eu

SERIE
21 - 23 P

RICAMBI ORIGINALI
Original Spare Parts
Pièces d'Origine
Originale Ersatzteile
Repuestos Originales

N° di codice - *N° de code* - Kodenummer - *Code N°* - N° de código: **4.150.686**
Edizione - *Edition* - Ausgabe - *Edition* - Edición: **11/2012**



SERIE 21 - 23 P

**Ed.
11/2012**

**Cod.
4.150.686**

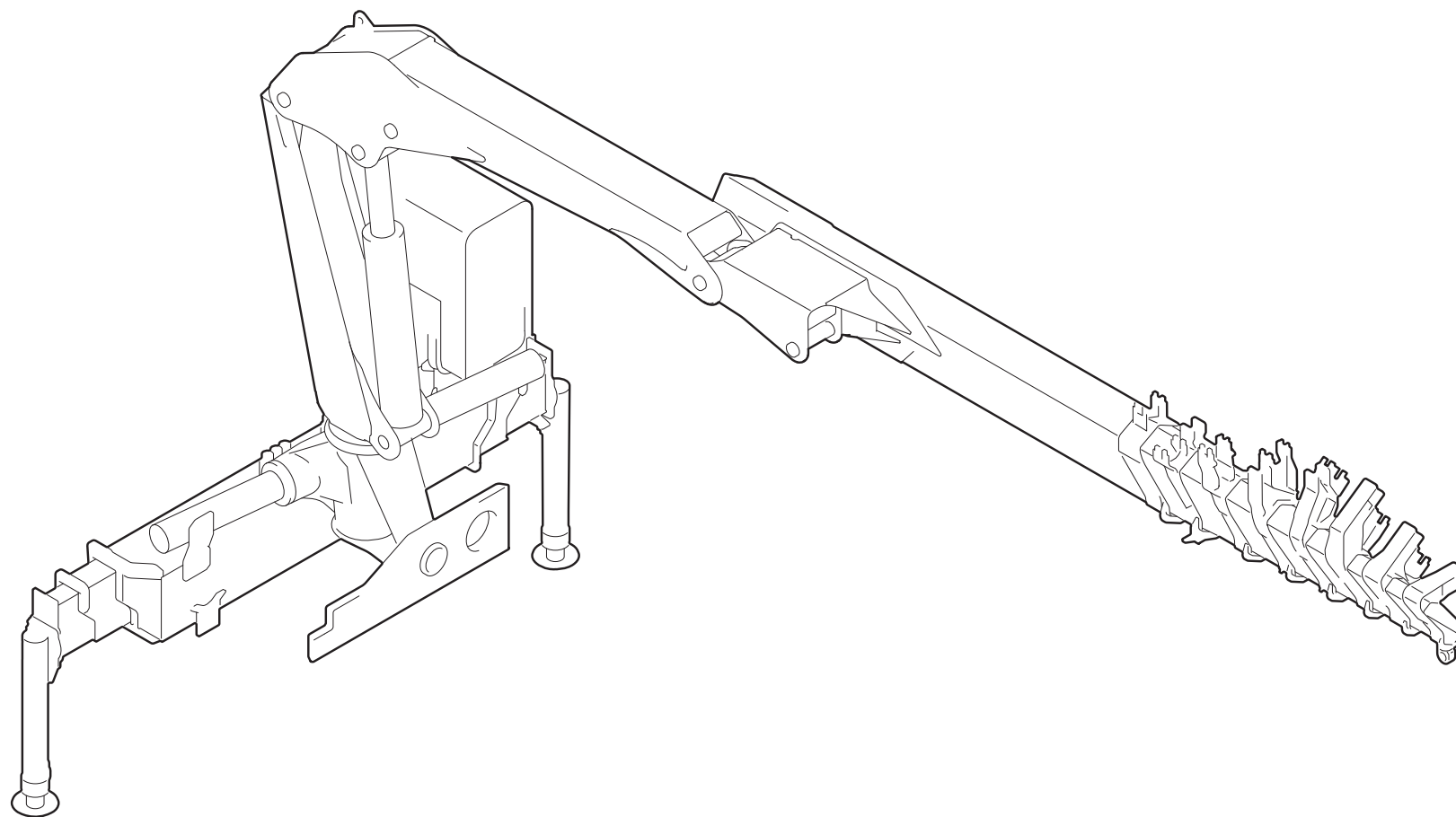



NORME PER LE ORDINAZIONI

Le ordinazioni dei ricambi devono essere corredate dalle seguenti indicazioni:

- A) *Modello della gru*
- B) *Numero di matricola*
- C) *Numero di identificazione del ricambio richiesto*
- D) *Quantità richiesta*
- E) *Denominazione*
- F) *Per i particolari provvisti di descrizione commerciale l'Autogru PM non fornisce ricambi*
- G) *Per l'ordinazione dei kit pattini consultare la pagina dell'ultimo braccio idraulico della versione interessata*

POUR COMMANDER LES PIECES DETACHEES

Donner toujours les indications suivantes:

- A) *Type de la grue*
- B) *Numéro de série*
- C) *Code de la pièce*
- D) *Quantité demandée*
- E) *Dénomination de la pièce*
- F) *Pour les détails avec description commerciale, l'Autogru PM ne fournit pas de pièces de rechange*
- G) *Pour la commande des kits de plaques d'usure, consulter la page de la dernière flèche hydraulique de la version en question*

BESTELLWEG

Ersatzteilenbestellungen müssen mit den folgenden Angaben ausgestattet werden:

- A) *Gruppentyp*
- B) *Fabriknummer*
- C) *Teilkennzeichen*
- D) *Menge je Teil*
- E) *Teilbenennung*
- F) *Ersatzteile für Bauteile anderer Hersteller werden von der PM Autogru nicht geliefert*
- G) *Zur Bestellung der Schlittensets beziehen Sie sich bitte auf den letzten Hydraulikauslegers in der zutreffenden Ausführung*

HOW TO ORDER SPARE PARTS

Any order for spare parts should be completed with the following dates:

- A) *Crane model*
- B) *Serial number*
- C) *Identification code number of the part required*
- D) *Quantity required*
- E) *Part denomination*
- F) *As far as parts featuring commercial descriptions are concerned, Autogru PM supplies no spare parts*
- G) *To order the sliding pad kit, consult the page describing the last hydraulic boom of the version*

REGLAS PARA LOS PEDIDOS

Pedidos de repuestos tienen que ser dotados de las siguientes indicaciones:

- A) *Modelo de la grua*
- B) *Numero de la matricula*
- C) *Numero matricula del repuesto pedido*
- D) *Cantidad pedida*
- E) *Denominación*
- F) *Para los particulares provistos de descripción comercial, Autogru PM no suministra piezas de repuesto*
- G) *Para ordenar el kit de patines de deslizamiento, consultar la página del último brazo hidráulico de la versión interesada*



1 - Modello della macchina

Modèle de la machine

Maschinemodell

Machine model

Modelo de la máquina

2 - Numero della tavola con indice di modifica

Numéro du plan avec indice de révision

Tafelnummer mit Änderungszahl

Table number with modification indication

Número de la lámina con índice de modificación

3 - Validità matricola della tavola

Validité matricule du plan

Gültigkeit der Seriennummer der Tafel

Validity of table number

Validez matricula de la lámina

4 - Numero di posizione del particolare

Numéro de position de la pièce

Positionsnummer des Teils

Position number of part

Número de posición de la pieza

5 - Numero di codice del particolare

Numéro de code de la pièce

Best. Nr. des Teils

Code number of part

Número de código de la pieza

6 - Quantità di particolari per tavola

Quantité de pièces par plan

Stückzahl der Teile pro Tafel

Quantity of parts per table

Cantidad de piezas por lámina



Norme per la consultazione del catalogo - Normes pour la consultation du catalogue
 Normen für die Katalogbenutzung - How to consult the catalogue - Normas para consultar el catálogo

Ed.
11/2012

21
23 P



BASE - ANCORAGGIO
 * Embase - ancrage
 * Kramfuß - Befestigungssatz
 * Base - anclaje kit
 * Base - kit de anclaje

TAV. GA.01.01
 matr. G.A107.0005

21
23 P

3 2 1

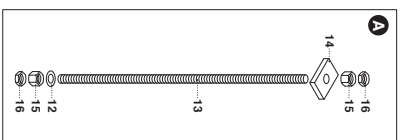
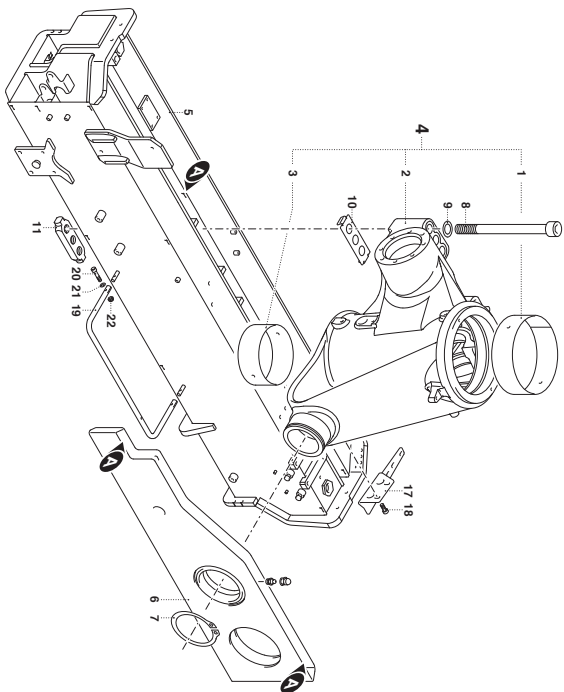
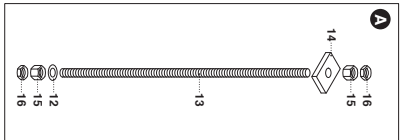

UNO1-R-1443.03

UNISTUDIO - Modem

PM 21 - PM 23 P

matr. GA107.0005

TAV. GA.01.01

POS. N° CODICE	Q.	DESCRIZIONE	DESIGNATION	BENENNING	DESCRIPTION	DENOMINACIONES
1	137388	1	BOCCOLA	DOUILLE	BUSHING	CASQUILLO
2	46744	1	SUPPORTO	TRÄGER	SUPPORT	SOPORTE
3	137351	1	BOCCOLA	DOUILLE	BUSHING	CASQUILLO
4	280980	1	KIT SUPPORTO ROTAZIONE	KIT SUPPORT ROTAZION	ROTATION SUPPORT KIT	KIT SOPORTE ROTACION
5	120945	1	TRAMERSA	QUERBALKEN	CROSSBEAM	TRAMERSA
6	467488	1	SUPPORTO	TRÄGER	SUPPORT	SOPORTE
7	109193	1	ANELLO ELASTICO	JOINT D'ARRÊT	SPRING RING	ANILLO ELASTICO
8	487487	6	VITE	VIS	SCHRAUBE	TORNILLO
9	417212	6	RONDELLA	RONDELLE	SCHIBE	ARANDELA
10	373905	2	PATTINO	PATIN	SLIDING BLOCK	PATIN
11	469157	2	STAFFA	ETRIER	BRACKET	ESTRIBO
12	417775	12	RONDELLA	RONDELLE	SCHIBE	ARANDELA
13	481189	6	TIRANTE	ZUGSTANGE	TIE ROD	TIRANTE
14	469066	6	STAFFA	ETRIER	BRACKET	ESTRIBO
15	191173	12	DADO	MUTTER	NUT	TUERCA
16	191087	12	DADO	ECHOU	NUT	TUERCA
17	467506	1	SUPPORTO	TRÄGER	SUPPORT	SOPORTE
18	487130	2	VITE	VIS	SCHRAUBE	TORNILLO

4 5 6



INDICE

* INDEX
* INDEX

* VERZEICHNIS
* INDICE

Ed.
11/2012

21
23 P

TAV. GA.01.01 BASE - ANCORAGGIO

- * Embase - ancrage
- * Kranfuß - Befestigungssatz
- * Base - anchorage kit
- * Base - kit de anclaje

TAV. GA.02.01 ROTAZIONE

- * Rotation
- * Drehung
- * Rotación
- * Rotación

TAV. GB.01.01 BRACCI STABILIZZATORI STANDARD - SFILO MANUALE

- * Bras stabilisateurs standard - extension manuelle
- * Standardstützarme - manuelle Ausziehen
- * Standard outrigger arms - manual extension
- * Brazos estabiliz. estándar - extensión manual

TAV. GB.01.02 BRACCI STABILIZZATORI STANDARD - SFILO IDRAULICO

- * Bras stabilisateurs standard - extension hydraulique
- * Standardstützarme - hydraulische Ausziehen
- * Standard outrigger arms - hydraulic extension
- * Brazos estabiliz. estándar - extensión hidraulica

TAV. GB.01.03 1/2 BRACCI STABILIZZATORI SUPER EXTRALARGHI

- * Bras stabilisateurs super extra larges
- * Superextrabreitestützarme
- * Super extra-large outrigger arms
- * Brazos estabiliz. super extra-anchos

TAV. GB.01.03 2/2 BRACCI STABILIZZATORI SUPER EXTRALARGHI

- * Bras stabilisateurs super extra larges
- * Superextrabreitestützarme
- * Super extra-large outrigger arms
- * Brazos estabiliz. super extra-anchos

TAV. GC.01.01 COLONNA

- * Colonne
- * Säule
- * Column
- * Columna

TAV. GC.02.01 LUBRIFICAZIONE ROTAZIONE CON OLIO

- * Graissage rotation avec huile
- * Schwenkschmierung mit Öl
- * Rotation lubrication with oil
- * Lubricación rotación con aceite



* INDEX
* INDEX

INDICE

* VERZEICHNIS
* INDICE

Ed.
11/2012

21
23 P

TAV. GC.02.02 LUBRIFICAZIONE ROTAZIONE CON GRASSO

- * Graissage rotation avec graisse
- * Schwenkschmierung mit Fett
- * Rotation lubrication with grease
- * Lubricación rotación con grasa

TAV. GD.01.01 BRACCIO PRINCIPALE

- * Bras principal
- * Hauptarm
- * Main arm
- * Brazo principal

TAV. GE.01.01 MARTINETTO STABILIZZATORI FISSI - 340434

- * Vérin stabilisateurs fixes
- * Feststützzylindern
- * Fixed outriggers cylinders
- * Cilindro estabilizadores fijos

TAV. GE.01.02 MARTINETTO STABILIZZATORI ROTANTI - 340428

- * Vérin stabilisateurs tournants
- * Drehstützzylindern
- * Rotating outriggers cylinders
- * Cilindro estabilizadores rotatorios

TAV. GE.02.01 MARTINETTO SFILO BRACCI STAB. STANDARD - 340420

- * Vérin extension bras stabilisateurs standard
- * Stützarmausziehenzylinder - standard
- * Standard outrigger arms extension cylinder
- * Cilindro extensión brazos estabilizadores estándar

TAV. GE.02.02 MARTINETTO SFILO BRACCI STAB. SUPER EXTRALARGHI - 340419

- * Vérin extension bras stabilisateurs super extra larges
- * Stützarmausziehenzylinder - super extrabreite
- * Super extra-large outrigger arms extension cylinder
- * Cilindro extensión brazos estabilizadores super extra-anchos

TAV. GF.01.01 MARTINETTO PRINCIPALE - 340439

- * Vérin principal
- * Hauptzylinder
- * Main cylinder
- * Cilindro principal

TAV. GF.02.01 MARTINETTO SECONDARIO - 340440

- * Vérin secondaire
- * Nebenzylinder
- * Secondary cylinder
- * Cilindro secundario



INDICE

* INDEX
* INDEX

* VERZEICHNIS
* INDICE

Ed.
11/2012

21
23 P

TAV. GG.01.01 FODERO (LC)

- * Fourreau (LC)
- * Futter (LC)
- * Cover (LC)
- * Camisa (LC)

TAV. GG.01.01A FODERO (LC)

- * Fourreau (LC)
- * Futter (LC)
- * Cover (LC)
- * Camisa (LC)

TAV. GG.02.01 BRACCIO SECONDARIO

- * Bras secondaire
- * Nebenarm
- * Secondary arm
- * Brazo secundario

TAV. GG.02.02 BRACCIO SECONDARIO (LC)

- * Bras secondaire
- * Nebenarm
- * Secondary arm
- * Brazo secundario

TAV. GG.02.02A BRACCIO SECONDARIO (LC)

- * Bras secondaire
- * Nebenarm
- * Secondary arm
- * Brazo secundario

TAV. GG.03.01 1° BRACCIO SFILO IDRAULICO

- * 1er bras - extension hydraulique
- * 1. Arm - hydraulische Ausziehen
- * 1st arm - hydraulic extension
- * 1er brazo - extensión hidráulica

TAV. GG.04.01 2° BRACCIO SFILO IDRAULICO (21023-24-25-26-27 - 23023-24-25-26-27 P)

- * 2ème bras - extension hydraulique
- * 2. Arm - hydraulische Ausziehen
- * 2nd arm - hydraulic extension
- * 2do brazo - extensión hidráulica

TAV. GG.04.02 2° BRACCIO SFILO IDRAULICO (21022 - 23022 P)

- * 2ème bras - extension hydraulique
- * 2. Arm - hydraulische Ausziehen
- * 2nd arm - hydraulic extension
- * 2do brazo - extensión hidráulica



INDICE

* INDEX
* INDEX

* VERZEICHNIS
* INDICE

Ed.
11/2012

21
23 P

TAV. GG.05.01 3° BRACCIO SFILO IDRAULICO (21024-25-26-27 - 23024-25-26-27 P)

- * 3ème bras - extension hydraulique
- * 3. Arm - hydraulische Ausziehen
- * 3rd arm - hydraulic extension
- * 3ero brazo - extensión hidráulica

TAV. GG.07.01 5° BRACCIO SFILO IDRAULICO (21026-27 - 23026-27 P)

- * 5ème bras - extension hydraulique
- * 5. Arm - hydraulische Ausziehen
- * 5th arm - hydraulic extension
- * 5to brazo - extensión hidráulica

TAV. GG.05.02 3° BRACCIO SFILO IDRAULICO (21023 - 23023 P)

- * 3ème bras - extension hydraulique
- * 3. Arm - hydraulische Ausziehen
- * 3rd arm - hydraulic extension
- * 3ero brazo - extensión hidráulica

TAV. GG.07.02 5° BRACCIO SFILO IDRAULICO (21025 - 23025 P)

- * 5ème bras - extension hydraulique
- * 5. Arm - hydraulische Ausziehen
- * 5th arm - hydraulic extension
- * 5to brazo - extensión hidráulica

TAV. GG.06.01 4° BRACCIO SFILO IDRAULICO (21025-26-27 - 23025-26-27 P)

- * 4ème bras - extension hydraulique
- * 4. Arm - hydraulische Ausziehen
- * 4th arm - hydraulic extension
- * 4to brazo - extensión hidráulica

TAV. GG.08.01 6° BRACCIO SFILO IDRAULICO (21027 - 23027 P)

- * 6ème bras - extension hydraulique
- * 6. Arm - hydraulische Ausziehen
- * 6th arm - hydraulic extension
- * 6to brazo - extensión hidráulica

TAV. GG.06.02 4° BRACCIO SFILO IDRAULICO (21024 - 23024 P)

- * 4ème bras - extension hydraulique
- * 4. Arm - hydraulische Ausziehen
- * 4th arm - hydraulic extension
- * 4to brazo - extensión hidráulica

TAV. GG.08.02 6° BRACCIO SFILO IDRAULICO (21026 - 23026 P)

- * 6ème bras - extension hydraulique
- * 6. Arm - hydraulische Ausziehen
- * 6th arm - hydraulic extension
- * 6to brazo - extensión hidráulica



INDICE

* INDEX
* INDEX

* VERZEICHNIS
* INDICE

Ed.
11/2012

21
23 P

TAV. GG.09.01 7° BRACCIO SFILO IDRAULICO (21027 - 23027 P)

- * 7ème bras - extension hydraulique
- * 7. Arm - hydraulische Ausziehen
- * 7th arm - hydraulic extension
- * 7mo brazo - extensión hidráulica

TAV. GH.02.02 MARTINETTO SFILO 1° BRACCIO IDRAULICO - 340549 (LC)

- * Vérin extension - 1er bras hydraulique (LC)
- * 1. Hydraulikarm - Ausziehenzylinder (LC)
- * Extension cylinder - 1st hydraulic arm (LC)
- * Cilindro extensión - 1er brazo hidráulico (LC)

TAV. GH.01.01 MARTINETTO SFILO BRACCIO SECONDARIO - 340505 (LC)

- * Vérin extension bras secondaire (LC)
- * Nebenarm - Ausziehenzylinder (LC)
- * Secondary arm - extension cylinder (LC)
- * Cilindro extensión brazo secundario (LC)

TAV. GH.03.01 MARTINETTO SFILO 2° BRACCIO IDRAULICO - 340413

- * Vérin extension - 2ème bras hydraulique
- * 2. Hydraulikarm - Ausziehenzylinder
- * Extension cylinder - 2nd hydraulic arm
- * Cilindro extensión - 2do brazo hidráulico

TAV. GH.01.01A MARTINETTO SFILO BRACCIO SECONDARIO - 340548 (LC)

- * Vérin extension bras secondaire (LC)
- * Nebenarm - Ausziehenzylinder (LC)
- * Secondary arm - extension cylinder (LC)
- * Cilindro extensión brazo secundario (LC)

TAV. GH.04.01 MARTINETTO SFILO 3° BRACCIO IDRAULICO - 340414

- * Vérin extension - 3ème bras hydraulique
- * 3. Hydraulikarm - Ausziehenzylinder
- * Extension cylinder - 3rd hydraulic arm
- * Cilindro extensión - 3ro brazo hidráulico

TAV. GH.02.01 MARTINETTO SFILO 1° BRACCIO IDRAULICO - 340412

- * Vérin extension - 1er bras hydraulique
- * 1. Hydraulikarm - Ausziehenzylinder
- * Extension cylinder - 1st hydraulic arm
- * Cilindro extensión - 1er brazo hidráulico

TAV. GH.05.01 MARTINETTO SFILO 4° BRACCIO IDRAULICO - 340415

- * Vérin extension - 4ème bras hydraulique
- * 4. Hydraulikarm - Ausziehenzylinder
- * Extension cylinder - 4th hydraulic arm
- * Cilindro extensión - 4to brazo hidráulico

**INDICE**

* INDEX
* INDEX

* VERZEICHNIS
* INDICE

Ed.
11/2012

21
23 P

TAV. GH.06.01 MARTINETTO SFILO 5° BRACCIO IDRAULICO - 340416

- * Vérin extension - 5ème bras hydraulique
- * 5. Hydraulikarm - Ausziehenzylinder
- * Extension cylinder - 5th hydraulic arm
- * Cilindro extensión - 5to brazo hidráulico

TAV. GH.07.01 MARTINETTO SFILO 6° BRACCIO IDRAULICO - 340416

- * Vérin extension - 6ème bras hydraulique
- * 6. Hydraulikarm - Ausziehenzylinder
- * Extension cylinder - 6th hydraulic arm
- * Cilindro extensión - 6to brazo hidráulico

TAV. GH.08.01 MARTINETTO SFILO 7° BRACCIO IDRAULICO - 340417

- * Vérin extension - 7ème bras hydraulique
- * 7. Hydraulikarm - Ausziehenzylinder
- * Extension cylinder - 7th hydraulic arm
- * Cilindro extensión - 7mo brazo hidráulico

TAV. GI.01.01 DOPPIO COMANDO - HYDROCONTROL - MANUALE (21)

- * Double commande - HYDROCONTROL - manuel
- * Zweiseitige Steuerung - HYDROCONTROL - manuelle
- * Dual side control - HYDROCONTROL - manual
- * Mando bilateral - HYDROCONTROL - manual

TAV. GI.01.02 DOPPIO COMANDO - HYDROCONTROL - RADIOCOMANDO (21)

- * Double commande - Hydrocontrol - Radiocommande
- * Zweiseitige Steuerung - Hydrocontrol - Fernsteuerung
- * Dual side control - Hydrocontrol - Radio control
- * Mando bilateral - Hydrocontrol - Radiomando

TAV. GI.01.03 COMANDO - DANFOSS (21)

- * Commande - DANFOSS
- * Steuerung - DANFOSS
- * Control - DANFOSS
- * Mando - DANFOSS

TAV. GI.01.04 COMANDO - DANFOSS (P.T.) (23 P)

- * Commande - DANFOSS (P.T.)
- * Steuerung - DANFOSS (P.T.)
- * Control - DANFOSS (P.T.)
- * Mando - DANFOSS (P.T.)

TAV. GI.01.05 DOPPIO COMANDO - HYDROCONTROL - 3° PUNTO DI MANOVRA (21)

- * Double commande - HYDROCONTROL - 3ème point de manœuvre
- * Zweiseitige Steuerung - HYDROCONTROL - 3. Manöverplatz
- * Dual side control - HYDROCONTROL - 3rd manoeuvre position
- * Mando bilateral - HYDROCONTROL - 3er punto de maniobra



INDICE

* INDEX
* INDEX

* VERZEICHNIS
* INDICE

Ed.
11/2012

21
23 P

TAV. GI.01.06 DOPPIO COMANDO - DANFOSS - 3° PUNTO DI MANOVRA (23 P)

- * Double commande - DANFOSS - 3ème point de manœuvre
- * Zweiseitige Steuerung - DANFOSS - 3. Manöverplatz
- * Dual side control - DANFOSS - 3rd manoeuvre position
- * Mando bilateral - DANFOSS - 3er punto de maniobra

TAV. GI.02.01 DOPPIO COMANDO - STABILIZZATORI

- * Double commande - Stabilisateurs
- * Zweiseitige Steuerung - Stabilisatoren
- * Dual side control - Outriggers
- * Mando bilateral - Estabilizadores

TAV. GI.03.01 TELAIO 3° PUNTO DI MANOVRA - HYDROCONTROL (MANUALE)

- * Châssis 3ème point de manœuvre - HYDROCONTROL (manuel)
- * Rahmen 3. Manöverplatz - HYDROCONTROL (manuelle)
- * Frame for the 3rd manoeuvre position - HYDROCONTROL (manual)
- * Bastidor 3er punto de maniobra - HYDROCONTROL (manual)

TAV. GI.03.02 TELAIO 3° PUNTO DI MANOVRA - RADIOCOMANDO

- * Châssis 3ème point de manœuvre - radiocommande
- * Rahmen 3. Manöverplatz - Fernsteuerung
- * Frame for the 3rd manoeuvre position - radio control
- * Bastidor 3er punto de maniobra - radiomando

TAV. GI.04.01 TELAIO 3° PUNTO DI MANOVRA - HYDROCONTROL (MANUALE)

- * Châssis 3ème point de manœuvre - HYDROCONTROL (manuel)
- * Rahmen 3. Manöverplatz - HYDROCONTROL (manuelle)
- * Frame for the 3rd manoeuvre position - HYDROCONTROL (manual)
- * Bastidor 3er punto de maniobra - HYDROCONTROL (manual)

TAV. GJ.01.01 MANDATA E SCARICO - HYDROCONTROL (21)

- * Conduit en pression et retour - HYDROCONTROL
- * Ausgus-und Auslaufschläuche - HYDROCONTROL
- * Delivery and return - HYDROCONTROL
- * Latiguillos de retorno - HYDROCONTROL

TAV. GJ.01.02 MANDATA E SCARICO - DANFOSS

- * Conduit en pression et retour - DANFOSS
- * Ausgus-und Auslaufschläuche - DANFOSS
- * Delivery and return - DANFOSS
- * Latiguillos de retorno - DANFOSS

TAV. GJ.02.01 IMPIANTO IDRAULICO COLLEGAMENTO DISTRIBUTORE (HYDROCONTROL-RADIOCOMANDO) (21)

- * Installation hydraulique jonction distributeur (Hydrocontrol-radiocommande)
- * Steuerventilverbindung-Hydraulischeanlage (Hydrocontrol-Funksteuerung)
- * Control valve block connection hydraulic system (Hydrocontro-Radio control)
- * Instalación neumática conexión distribuidor (Hydrocontrol-Radiocontrol)

**INDICE**

* INDEX
* INDEX

* VERZEICHNIS
* INDICE

Ed.
11/2012

21
23 P

TAV. GJ.02.02 IMPIANTO IDRAULICO COLLEGAMENTO DISTRIBUTORE (HYDROCONTROL-RADIOCOMANDO) (21)

- * Installation hydraulique jonction distributeur (Hydrocontrol-radiocommande)
- * Steuerventilverbindung-Hydraulischeanlage (Hydrocontrol-Funksteuerung)
- * Control valve block connection hydraulic system (Hydrocontro-Radio control)
- * Instalación neumática conexión distribuidor (Hydrocontrol-Radiocontrol)

TAV. GJ.03.04 DISTRIBUTORE BRACCI STABILIZZATORI DANFOSS (23 P)

- * Distributeur bras stabilisateurs DANFOSS
- * DANFOSS Stützarme Steuerventil
- * DANFOSS outrigger arms control valve
- * Distribuidor brazos estabilizadores DANFOSS

TAV. GJ.03.01 DISTRIBUTORE BRACCI STABILIZZATORI HYDROCONTROL - DANFOSS (21)

- * Distributeur bras stabilisateurs HYDROCONTROL - DANFOSS
- * HYDROCONTROL Stützarme Steuerventil - DANFOSS
- * HYDROCONTROL outrigger arms control valve - DANFOSS
- * Distribuidor brazos estabilizadores HYDROCONTROL - DANFOSS

TAV. GK.01.01 1/2 COMANDO BRACCI STABILIZZATORI

- * Commande bras stabilisateurs
- * Stützarmesteuerung
- * Outrigger arms control
- * Mando brazos estabilizadores

TAV. GJ.03.02 DISTRIBUTORE BRACCI STABILIZZATORI DANFOSS SENZA "MCS"

- * Distributeur bras stabilisateurs DANFOSS sans "MCS"
- * DANFOSS Stützarme Steuerventil ohne "MCS"
- * DANFOSS outrigger arms control valve without "MCS"
- * Distribuidor brazos estabilizadores DANFOSS sin "MCS"

TAV. GK.01.01 2/2 COMANDO BRACCI STABILIZZATORI

- * Commande bras stabilisateurs
- * Stützarmesteuerung
- * Outrigger arms control
- * Mando brazos estabilizadores

TAV. GJ.03.03 DISTRIBUTORE "MCS" BRACCI STABILIZZATORI (23 P)

- * Distributeur "MCS" bras stabilisateurs
- * Stützarme "MCS" Steuerventil
- * Outrigger arms "MCS" control valve
- * Distribuidor "MCS" brazos estabilizadores

TAV. GK.02.01 KIT MARTINETTO STABILIZZATORI FISSI - 340434

- * Kit vérin stabilisateurs fixes
- * Feststützzyllindersatz
- * Fixed outriggers cylinders kit
- * Kit cilindro estabilizadores fijos



INDICE

* INDEX
* INDEX

* VERZEICHNIS
* INDICE

Ed.
11/2012

21
23 P

TAV. GK.02.02 KIT MARTINETTO STABILIZZATORI ROTANTI - 340428

- * Kit vérin stabilisateurs tournants
- * Drehstützylinderersatz
- * Rotating outriggers cylinders kit
- * Kit cilindro estabilizadores rotatorios

TAV. GK.03.01 1/2 COMANDO MARTINETTO STABILIZZATORE (BRACCI STANDARD MANUALI FISSI-ROTANTI)

- * Commande vérin stabilisateur (bras standard manuels fixes-tournants)
- * Stützzylindersteuerung (Fest-Dreh-Manual Standardarme)
- * Outrigger cylinder control (fixed-rotating manual standard arms)
- * Mando gatos de apoyo (brazos estándar manuales fijos-rotatorios)

TAV. GK.03.01 2/2 COMANDO MARTINETTO STABILIZZATORE (BRACCI STANDARD MANUALI FISSI-ROTANTI)

- * Commande vérin stabilisateur (bras standard manuels fixes-tournants)
- * Stützzylindersteuerung (Fest-Dreh-Manual Standardarme)
- * Outrigger cylinder control (fixed-rotating manual standard arms)
- * Mando gatos de apoyo (brazos estándar manuales fijos-rotatorios)

TAV. GK.03.02 1/2 COMANDO MARTINETTO STABILIZZATORE (BRACCI STANDARD IDRAULICI FISSI-ROTANTI)

- * Commande vérin stabilisateur (bras standard hydrauliques fixes-tournants)
- * Stützzylindersteuerung (Fest-Dreh-Hydraulik Standardarme)
- * Outrigger cylinder control (fixed-rotating hydraulic standard arms)
- * Mando gatos de apoyo (brazos estándar hidráulicos fijos-rotatorios)

TAV. GK.03.02 2/2 COMANDO MARTINETTO STABILIZZATORE (BRACCI STANDARD IDRAULICI FISSI-ROTANTI)

- * Commande vérin stabilisateur (bras standard hydrauliques fixes-tournants)
- * Stützzylindersteuerung (Fest-Dreh-Hydraulik Standardarme)
- * Outrigger cylinder control (fixed-rotating hydraulic standard arms)
- * Mando gatos de apoyo (brazos estándar hidráulicos fijos-rotatorios)

TAV. GK.03.03 1/2 COMANDO MARTINETTO STABILIZZATORE (BRACCI SUPER EXTRALARGHI IDRAULICI FISSI-ROTANTI)

- * Commande vérin stabilisateur (bras super extra larges hydrauliques fixes-tournants)
- * Stützzylindersteuerung (Fest-Dreh-Hydraulik super Extrabreitearme)
- * Outrigger cylinder control (fixed-rotating hydraulic super extra-large arms)
- * Mando gatos de apoyo (brazos super extra anchos hidráulicos fijos-rotatorios)

TAV. GK.03.03 2/2 COMANDO MARTINETTO STABILIZZATORE (BRACCI SUPER EXTRALARGHI IDRAULICI FISSI-ROTANTI)

- * Commande vérin stabilisateur (bras super extra larges hydrauliques fixes-tournants)
- * Stützzylindersteuerung (Fest-Dreh-Hydraulik super Extrabreitearme)
- * Outrigger cylinder control (fixed-rotating hydraulic super extra-large arms)
- * Mando gatos de apoyo (brazos super extra anchos hidráulicos fijos-rotatorios)

TAV. GK.04.01 COMANDO ROTAZIONE - HYDROCONTROL (21)

- * Commande rotation - HYDROCONTROL
- * Schwenksteuerung - HYDROCONTROL
- * Rotation control - HYDROCONTROL
- * Mando rotación - HYDROCONTROL

**INDICE**

* INDEX
* INDEX

* VERZEICHNIS
* INDICE

Ed.
11/2012

21
23 P

TAV. GK.04.02 COMANDO ROTAZIONE - DANFOSS

- * Commande rotation - DANFOSS
- * Schwenksteuerung - DANFOSS
- * Rotation control - DANFOSS
- * Mando rotación - DANFOSS

TAV. GK.04.03 COMANDO ROTAZIONE - VALVOLA BLOCCO

- * Commande rotation - Soupape blocage
- * Schwenksteuerung - Sperrventil
- * Rotation control - Lock valve
- * Mando rotación - Valvula bloqueo

TAV. GK.05.01 COMANDO MARTINETTO PRINCIPALE - HYDROCONTROL (21)

- * Commande vérin principal - HYDROCONTROL
- * Hauptzylindersteuerung - HYDROCONTROL
- * Main cylinder control - HYDROCONTROL
- * Mando cilindro principal - HYDROCONTROL

TAV. GK.05.02 COMANDO MARTINETTO PRINCIPALE - DANFOSS

- * Commande vérin principal - DANFOSS
- * Hauptzylindersteuerung - DANFOSS
- * Main cylinder control - DANFOSS
- * Mando cilindro principal - DANFOSS

TAV. GK.06.01 COMANDO MARTINETTO SECONDARIO - HYDROCONTROL (21)

- * Commande vérin secondaire - HYDROCONTROL
- * Nebenzylindersteuerung - HYDROCONTROL
- * Secondary cylinder control - HYDROCONTROL
- * Mando cilindro secundario - HYDROCONTROL

TAV. GK.06.02 COMANDO MARTINETTO SECONDARIO - DANFOSS

- * Commande vérin secondaire - DANFOSS
- * Nebenzylindersteuerung - DANFOSS
- * Secondary cylinder control - DANFOSS
- * Mando cilindro secundario - DANFOSS

TAV. GK.07.01 COMANDO MARTINETTO SFILO BRACCI IDRAULICI - HYDROCONTROL (21)

- * Commande vérin extension bras hydrauliques - HYDROCONTROL
- * Hydraulicarme Ausziehenzylindersteuerung - HYDROCONTROL
- * Hydraulic arms extension cylinder control - HYDROCONTROL
- * Mando cilindro extensión brazos hidráulicos - HYDROCONTROL

TAV. GK.07.02 COMANDO MARTINETTO SFILO BRACCI IDRAULICI - DANFOSS

- * Commande vérin extension bras hydrauliques - DANFOSS
- * Hydraulicarme Ausziehenzylindersteuerung - DANFOSS
- * Hydraulic arms extension cylinder control - DANFOSS
- * Mando cilindro extensión brazos hidráulicos - DANFOSS



INDICE

* INDEX
* INDEX

* VERZEICHNIS
* INDICE

Ed.
11/2012

21
23 P

TAV. GK.07.03 COMANDO MARTINETTO SFILO BRACCI IDRAULICI - HYDRO-CONTROL - 3° PUNTO DI MANOVRA (21)

- * Commande vérin extension bras hydr. - HYDROCONTROL - 3ème point de manœuvre
- * Hydraulicarme Ausziehzylindersteuerung - HYDROCONTROL - 3. Manöverplatz
- * Hydr. arms extension cylinder control - HYDROCONTROL - 3rd manoeuvre position
- * Mando cilindro extensión brazos hidr. - HYDROCONTROL - 3er punto de maniobra

TAV. GK.07.04 COMANDO MARTINETTO SFILO BRACCI IDRAULICI - DANFOSS - 3° PUNTO DI MANOVRA

- * Commande vérin extension bras hydrauliques - DANFOSS - 3ème point de manœuvre
- * Hydraulicarme Ausziehzylindersteuerung - DANFOSS - 3. Manöverplatz
- * Hydraulic arms extension cylinder control - DANFOSS - 3rd manoeuvre position
- * Mando cilindro extensión brazos hidráulicos - DANFOSS - 3er punto de maniobra

TAV. GL.01.01 1/2 COMPL. COMANDO MARTINETTO SFILO BRACCI IDRAULICI (SECONDARIO/1°/2°) (LC)

- * Compl. commande vérin extension bras hydrauliques (secondaire/1er/2ème) (LC)
- * Ergänzung des Steuerungs der Hydraulischearmeausziehzylinder (Neben/1./2.) (LC)
- * Hydraulic arms extension cylinder control - compl. (secondary/1st/2nd) (LC)
- * Complet. mando cilindro extensión brazos hidráulicos (secundario/1ro/2do) (LC)

TAV. GL.01.01A 1/2 COMPL. COMANDO MARTINETTO SFILO BRACCI IDRAULICI (SECONDARIO/1°/2°) (LC)

- * Compl. commande vérin extension bras hydrauliques (secondaire/1er/2ème) (LC)
- * Ergänzung des Steuerungs der Hydraulischearmeausziehzylinder (Neben/1./2.) (LC)
- * Hydraulic arms extension cylinder control - compl. (secondary/1st/2nd) (LC)
- * Complet. mando cilindro extensión brazos hidráulicos (secundario/1ro/2do) (LC)

TAV. GL.01.01 2/2 COMPL. COMANDO MARTINETTO SFILO BRACCI IDRAULICI (SECONDARIO/1°/2°) (LC)

- * Compl. commande vérin extension bras hydrauliques (secondaire/1er/2ème) (LC)
- * Ergänzung des Steuerungs der Hydraulischearmeausziehzylinder (Neben/1./2.) (LC)
- * Hydraulic arms extension cylinder control - compl. (secondary/1st/2nd) (LC)
- * Complet. mando cilindro extensión brazos hidráulicos (secundario/1ro/2do) (LC)

TAV. GL.02.01 COMPL. COMANDO MARTINETTO SFILO 1° / 2° BRACCIO IDRAULICO

- * Compl. commande vérin extension 1er/2ème bras hydraulique
- * Hydr. 1./2. Arm Ausziehzylindersteuerung - Ergänzung
- * Hydraulic 1st/2nd arm extension cylinder control compl.
- * Complet. mando cilindro extensión 1°/2° brazo hidráulico

TAV. GL.03.01 COMPL. COMANDO MARTINETTO SFILO 3° BRACCIO IDRAULICO

- * Compl. commande vérin extension 3ème bras hydrauliques
- * Hydr. 3. Arm Ausziehzylindersteuerung - Ergänzung
- * Hydraulic 3rd arm extension cylinder control compl.
- * Complet. mando cilindro extensión 3° brazo hidráulico

TAV. GL.04.01 COMPL. COMANDO MARTINETTO SFILO 4° BRACCIO IDRAULICO

- * Compl. commande vérin extension 4ème bras hydrauliques
- * Hydr. 4. Arm Ausziehzylindersteuerung - Ergänzung
- * Hydraulic 4th arm extension cylinder control compl.
- * Complet. mando cilindro extensión 4° brazo hidráulico

**INDICE**

* INDEX
* INDEX

* VERZEICHNIS
* INDICE

Ed.
11/2012

21
23 P

**TAV. GL.05.01 COMPL. COMANDO MARTINETTO SFILO 5° BRACCIO IDRAU-
LICO**

- * Compl. commande vérin extension 5ème bras hydrauliques
- * Hydr. 5. Arm Ausziehzylindersteuerung - Ergänzung
- * Hydraulic 5th arm extension cylinder control compl.
- * Complet. mando cilindro extensión 5° brazo hidráulico

**TAV. GL.06.01 COMPL. COMANDO MARTINETTO SFILO 6° BRACCIO IDRAU-
LICO**

- * Compl. commande vérin extension 6ème bras hydrauliques
- * Hydr. 6 Arm Ausziehzylindersteuerung - Ergänzung
- * Hydraulic 6th arm extension cylinder control compl.
- * Complet. mando cilindro extensión 6° brazo hidráulico

**TAV. GL.07.01 COMPL. COMANDO MARTINETTO SFILO 7° BRACCIO IDRAU-
LICO**

- * Compl. commande vérin extension 7ème bras hydrauliques
- * Hydr. 7 Arm Ausziehzylindersteuerung - Ergänzung
- * Hydraulic 7th arm extension cylinder control compl.
- * Complet. mando cilindro extensión 7° brazo hidráulico

TAV. GM.01.01 LUBRIFICAZIONE CENTRALIZZATA

- * Graissage centralisé
- * Sammelschmierung
- * Centralised lubrication
- * Lubricación centralizada

TAV. GN.01.01 DISTRIBUTORE DANFOSS 5 ELEMENTI - H -197673 (21)

- * Distributeur DANFOSS - 5 éléments - H
- * DANFOSS-Steuerventilblock - 5 Elemente - H
- * DANFOSS control valve block - 5 elements - H
- * Distribuidor DANFOSS 5 elementos - H

**TAV. GN.01.02 DISTRIBUTORE DANFOSS 6 ELEMENTI - H - 1° ATTIVAZIONE -
197675 (21)**

- * Distributeur DANFOSS - 6 éléments - H 1ère activation
- * DANFOSS-Steuerventilblock - 6 Elemente - H - 1. Betätigung
- * DANFOSS control valve block - 6 elements - H - 1st activation
- * Distribuidor DANFOSS 6 elementos - H - 1era activación

**TAV. GN.01.03 DISTRIBUTORE DANFOSS 6 ELEMENTI - H - ARGANO - 197674
(21)**

- * Distributeur DANFOSS - 6 éléments - H - treuil
- * DANFOSS-Steuerventilblock - 6 Elemente - H - Winde
- * DANFOSS control valve block - 6 elements - H - winch
- * Distribuidor DANFOSS 6 elementos - H - cabrestante

**TAV. GN.01.04 DISTRIBUTORE DANFOSS 7 ELEMENTI - H - 2° ATTIVAZIONE -
197676 (21)**

- * Distributeur DANFOSS - 7 éléments - H 2ème activation
- * DANFOSS-Steuerventilblock - 7 Elemente - H - 2. Betätigung
- * DANFOSS control valve block - 7 elements - H - 2nd activation
- * Distribuidor DANFOSS 7 elementos - H - 2da activación



INDICE

* INDEX
* INDEX

* VERZEICHNIS
* INDICE

Ed.
11/2012

21
23 P

TAV. GN.01.05 **DISTRIBUTORE DANFOSS 5 ELEMENTI - A - 197669 (21)**

- * Distributeur DANFOSS - 5 éléments - A
- * DANFOSS-Steuerventilblock - 5 Elemente - A
- * DANFOSS control valve block - 5 elements - A
- * Distribuidor DANFOSS 5 elementos - A

TAV. GN.01.06 **DISTRIBUTORE DANFOSS 6 ELEMENTI - A - 1° ATTIVAZIONE - 197671 (21)**

- * Distributeur DANFOSS - 6 éléments - A 1ère activation
- * DANFOSS-Steuerventilblock - 6 Elemente - A - 1. Betätigung
- * DANFOSS control valve block - 6 elements - A - 1st activation
- * Distribuidor DANFOSS 6 elementos - A - 1era activación

TAV. GN.01.07 **DISTRIBUTORE DANFOSS 6 ELEMENTI A - ARGANO - 197670 (21)**

- * Distributeur DANFOSS - 6 éléments A - treuil
- * DANFOSS-Steuerventilblock - 6 Elemente A - Winde
- * DANFOSS control valve block - 6 elements A - winch
- * Distribuidor DANFOSS 6 elementos A -cabrestante

TAV. GN.01.08 **DISTRIBUTORE DANFOSS 7 ELEMENTI - A - 2° ATTIVAZIONE - 197672 (21)**

- * Distributeur DANFOSS - 7 éléments - A 2ème activation
- * DANFOSS-Steuerventilblock - 7 Elemente - A - 2. Betätigung
- * DANFOSS control valve block - 7 elements - A - 2nd activation
- * Distribuidor DANFOSS 7 elementos - A - 2da activación

TAV. GN.02.01 **DISTRIBUTORE DANFOSS 4 ELEMENTI - H - 197568 (23 P)**

- * Distributeur DANFOSS - 4 éléments - H
- * DANFOSS-Steuerventilblock - 4 Elemente - H
- * DANFOSS control valve block - 4 elements - H
- * Distribuidor DANFOSS 4 elementos - H

TAV. GN.02.02 **DISTRIBUTORE DANFOSS 5 ELEMENTI - H - 1° ATTIVAZIONE - 497569 (23 P)**

- * Distributeur DANFOSS - 5 éléments - H 1ère activation
- * DANFOSS-Steuerventilblock - 5 Elemente - H - 1. Betätigung
- * DANFOSS control valve block - 5 elements - H - 1st activation
- * Distribuidor DANFOSS 5 elementos - H - 1era activación

TAV. GN.02.03 **DISTRIBUTORE DANFOSS 5 ELEMENTI H - ARGANO - 197571 (23 P)**

- * Distributeur DANFOSS - 5 éléments H - treuil
- * DANFOSS-Steuerventilblock - 5 Elemente H - Winde
- * DANFOSS control valve block - 5 elements H - winch
- * Distribuidor DANFOSS 5 elementos H -cabrestante

TAV. GN.02.04 **DISTRIBUTORE DANFOSS 6 ELEMENTI - H - 2° ATTIVAZIONE - 197570 (23 P)**

- * Distributeur DANFOSS - 6 éléments - H 2ème activation
- * DANFOSS-Steuerventilblock - 6 Elemente - H - 2. Betätigung
- * DANFOSS control valve block - 6 elements - H - 2nd activation
- * Distribuidor DANFOSS 6 elementos - H - 2da activación

**INDICE**

* INDEX
* INDEX

* VERZEICHNIS
* INDICE

Ed.
11/2012

21
23 P

TAV. GN.02.05 DISTRIBUTORE DANFOSS 6 ELEMENTI H - PROLUNGA ARTICOLATA - 197572 (23 P)

- * Distributeur DANFOSS - 6 éléments H - rallonge articulée
- * DANFOSS-Steuerventilblock - 6 Elemente H - Gelenkverlängerung
- * DANFOSS control valve block - 6 elements H - jib
- * Distribuidor DANFOSS 6 elementos H -extensión articulada

TAV. GN.02.09 DISTRIBUTORE DANFOSS 5 ELEMENTI A - ARGANO - 197552 (23 P)

- * Distributeur DANFOSS - 5 éléments A - treuil
- * DANFOSS-Steuerventilblock - 5 Elemente A - Winde
- * DANFOSS control valve block - 5 elements A - winch
- * Distribuidor DANFOSS 5 elementos A -cabrestante

TAV. GN.02.06 DISTRIBUTORE DANFOSS 7 ELEMENTI H - PROLUNGA ARTICOLATA - ARGANO - 197573 (23 P)

- * Distributeur DANFOSS - 7 éléments H - rallonge articulée - treuil
- * DANFOSS-Steuerventilblock - 7 Elemente H - Gelenkverlängerung - Winde
- * DANFOSS control valve block - 7 elements H - jib - winch
- * Distribuidor DANFOSS 6 elementos H -extensión articulada - cabrestante

TAV. GN.02.10 DISTRIBUTORE DANFOSS 6 ELEMENTI - A - 2° ATTIVAZIONE - 197553 (23 P)

- * Distributeur DANFOSS - 6 éléments - A 2ème activation
- * DANFOSS-Steuerventilblock - 6 Elemente - A - 2. Betätigung
- * DANFOSS control valve block - 6 elements - A - 2nd activation
- * Distribuidor DANFOSS 6 elementos - A - 2da activación

TAV. GN.02.07 DISTRIBUTORE DANFOSS 4 ELEMENTI - A - 197570 (23 P)

- * Distributeur DANFOSS - 4 éléments - A
- * DANFOSS-Steuerventilblock - 4 Elemente - A
- * DANFOSS control valve block - 4 elements - A
- * Distribuidor DANFOSS 4 elementos - A

TAV. GN.02.11 DISTRIBUTORE DANFOSS 6 ELEMENTI A - PROLUNGA ARTICOLATA - 197554 (23 P)

- * Distributeur DANFOSS - 6 éléments A - rallonge articulée
- * DANFOSS-Steuerventilblock - 6 Elemente A - Gelenkverlängerung
- * DANFOSS control valve block - 6 elements A - jib
- * Distribuidor DANFOSS 6 elementos A -extensión articulada

TAV. GN.02.08 DISTRIBUTORE DANFOSS 5 ELEMENTI - A - 1° ATTIVAZIONE - 197551 (23 P)

- * Distributeur DANFOSS - 5 éléments - A 1ère activation
- * DANFOSS-Steuerventilblock - 5 Elemente - A - 1. Betätigung
- * DANFOSS control valve block - 5 elements - A - 1st activation
- * Distribuidor DANFOSS 5 elementos - A - 1era activación

TAV. GN.02.12 DISTRIBUTORE DANFOSS 7 ELEMENTI A - PROLUNGA ARTICOLATA - ARGANO - 197567 (23 P)

- * Distributeur DANFOSS - 7 éléments A - rallonge articulée - treuil
- * DANFOSS-Steuerventilblock - 7 Elemente A - Gelenkverlängerung - Winde
- * DANFOSS control valve block - 7 elements A - jib - winch
- * Distribuidor DANFOSS 6 elementos A -extensión articulada - cabrestante



INDICE

* INDEX
* INDEX

* VERZEICHNIS
* INDICE

Ed.
11/2012

21
23 P

TAV. GN.04.01 DISTRIBUTORE 5 ELEMENTI - HC - D4/5 - 197665 (21)

- * Distributeur - 5 éléments - HC - D4/5
- * Steuerventilblock - 5 Elemente - HC - D4/5
- * Control valve block - 5 elements - HC - D4/5
- * Distribuidor 5 elementos - HC - D4/5

TAV. GN.04.02 DISTRIBUTORE 6 ELEMENTI - HC - D4/6 - 197667 (21)

- * Distributeur - 6 éléments - HC D4/6
- * Steuerventilblock - 6 Elemente - HC D4/6
- * Control valve block - 6 elements - HC D4/6
- * Distribuidor 6 elementos - HC D4/6

TAV. GN.04.03 DISTRIBUTORE 7 ELEMENTI - HC D4/7 - 197668 (21)

- * Distributeur - 7 éléments - HC D4/7
- * Steuerventilblock - 7 Elemente - HC D4/7
- * Control valve block - 7 elements - HC D4/7
- * Distribuidor 7 elementos - HC D4/7

TAV. GN.04.04 DISTRIBUTORE 6 ELEMENTI - HC - D4/6 - ARGANO - 197666 (21)

- * Distributeur - 6 éléments - HC D4/6 - treuil
- * Steuerventilblock - 6 Elemente - HC D4/6 - Winde
- * Control valve block - 6 elements - HC D4/6 - winch
- * Distribuidor 6 elementos - HC D4/6 - cabrestante

TAV. GN.05.01 DISTRIBUTORE BRACCI STABILIZZATORI WALVOIL - 197534

- * Distributeur bras stabilisateurs WALVOIL
- * WALVOIL Stützarme Steuerventil
- * WALVOIL outrigger arms control valve
- * Distribuidor brazos estabilizadores WALVOIL

TAV. GO.01.01 TARGHETTE COMANDI

- * Autocollants commandes
- * Steuerungsschilder
- * Control decals
- * Etiquetas mandos

TAV. GO.01.02 TARGHETTE COMANDI (21)

- * Autocollants commandes
- * Steuerungsschilder
- * Control decals
- * Etiquetas mandos

TAV. GO.01.03 TARGHETTE COMANDI STABILIZZATORI SENZA "MCS"

- * Autocollants commandes stabilisateurs sans "MCS"
- * Stützsteuerungsschilder ohne "MCS"
- * Outriggers control decals without "MCS"
- * Etiquetas mandos estabilizadores sin "MCS"

**INDICE**

* INDEX
* INDEX

* VERZEICHNIS
* INDICE

Ed.
11/2012

21
23 P

TAV. GO.01.04 TARGHETTE COMANDI STABILIZZATORI CON "MCS" (23 P)

- * Autocollants commandes stabilisateurs avec "MCS"
- * Stützsteuerungsschilder mit "MCS"
- * Outriggers control decals with "MCS"
- * Etiquetas mandos estabilizadores con "MCS"

TAV. GO.05.01 TARGHETTE (23 P) (LC)

- * Autocollants
- * Schilder
- * Decals
- * Etiquetas

TAV. GO.02.01 TARGHETTE (21)

- * Autocollants
- * Schilder
- * Decals
- * Etiquetas

TAV. ST.01.01 1° PROLUNGA MECCANICA (21023 - 23023 P)

- * 1ère rallonge mécanique
- * 1. mechanische Verlängerung
- * 1st mechanical extension
- * 1era prolonga mecánica

TAV. GO.03.01 TARGHETTE (21) (LC)

- * Autocollants
- * Schilder
- * Decals
- * Etiquetas

TAV. ST.02.01 1° PROLUNGA MECCANICA (21024 - 23024 P) - 2° PROLUNGA MECCANICA (21023 - 23023 P)

- * 1ère rallonge mécanique - 2ème rallonge mécanique
- * 1. mechanische Verlängerung - 2. mechanische Verlängerung
- * 1st mechanical extension - 2nd mechanical extension
- * 1era prolonga mecánica - 2da prolonga mecánica

TAV. GO.04.01 TARGHETTE (23 P)

- * Autocollants
- * Schilder
- * Decals
- * Etiquetas

TAV. ST.03.01 1° PROLUNGA MECCANICA (21025 - 23025 P) - 2° PROLUNGA MECCANICA (21024 - 23024 P) - 3° PROLUNGA MECCANICA (21023 - 23023 P)

- * 1ère rallonge mécanique - 2ème rallonge mécanique - 3ème rallonge mécanique
- * 1. mechanische Verlängerung - 2. mechanische Verlängerung - 3. mechanische Verlängerung
- * 1st mechanical extension - 2nd mechanical extension - 3rd mechanical extension
- * 1era prolonga mecánica - 2da prolonga mecánica - 3cera prolonga mecánica



INDICE

* INDEX
* INDEX

* VERZEICHNIS
* INDICE

Ed.
11/2012

21
23 P

TAV. ST.04.01 1° PROLUNGA MECCANICA (21026 - 23026 P) - 2° PROLUNGA MECCANICA (21025 - 23025 P)

- * 1ère rallonge mécanique - 2ème rallonge mécanique
- * 1. mechanische Verlängerung - 2. mechanische Verlängerung
- * 1st mechanical extension - 2nd mechanical extension
- * 1era prolonga mecánica - 2da prolonga mecánica

TAV. SU.01.01 1/2 LIMITATORE DI MOMENTO - HYDROCONTROL (21)

- * Limiteur de moment - HYDROCONTROL
- * Momentbegrenzer - HYDROCONTROL
- * Moment control device - HYDROCONTROL
- * Sistema limitador de momento - HYDROCONTROL

TAV. SU.01.01 2/2 LIMITATORE DI MOMENTO - HYDROCONTROL (21)

- * Limiteur de moment - HYDROCONTROL
- * Momentbegrenzer - HYDROCONTROL
- * Moment control device - HYDROCONTROL
- * Sistema limitador de momento - HYDROCONTROL

TAV. SU.01.02 1/2 LIMITATORE DI MOMENTO - DANFOSS (21)

- * Limiteur de moment - DANFOSS
- * Momentbegrenzer - DANFOSS
- * Moment control device - DANFOSS
- * Sistema limitador de momento - DANFOSS

TAV. SU.01.02 2/2 LIMITATORE DI MOMENTO - DANFOSS (21)

- * Limiteur de moment - DANFOSS
- * Momentbegrenzer - DANFOSS
- * Moment control device - DANFOSS
- * Sistema limitador de momento - DANFOSS

TAV. SU.02.01 COMPL. IMPIANTO SENZA LIMITATORE (HYDROCONTROL - RADIOCOMANDO) (21)

- * Compl. installation sans limiteur (HYDROCONTROL - Radiocommande)
- * Anlagebetätigung ohne Begrenzer (HYDROCONTROL - Fernsteuerung)
- * System completion without limiting device (HYDROCONTROL - Radio control)
- * Complet. instalación sin limitador (HYDROCONTROL - Radiomando)

TAV. SV.01.01 1/2 COMANDO 1° ATTIVAZIONE - AVVOLGITUBO

- * Commande 1ère activation - enrouleur
- * 1. Betätigungssteuerung - Schlauchwickler
- * 1st activation control - hose reel
- * Mando 1era activación con enrollador

TAV. SV.01.01 2/2 COMPL. COMANDO 1° ATTIVAZIONE - AVVOLGITUBO

- * Compl. commande 1ère activation - enrouleur
- * Steuerung 1. Aktivierung - Ergänzung - Schlauchwickler
- * 1st activation control compl. - hose reel
- * Complet. mando 1° activación - enrollador



* INDEX
* INDEX

INDICE

* VERZEICHNIS
* INDICE

Ed.
11/2012

21
23 P

TAV. SV.02.01 1/2 COMANDO 2° ATTIVAZIONE - AVVOLGITUBO

- * Commande 1ère activation - enrouleur
- * 1. Betätigungssteuerung - Schlauchwickler
- * 1st activation control - hose reel
- * Mando 1era activación con enrollador

TAV. SV.02.01 2/2 COMPL. COMANDO 2° ATTIVAZIONE - AVVOLGITUBO

- * Compl. commande 2ème activation - enrouleur
- * Steuerung 2. Aktivierung - Ergänzung - Schlauchwickler
- * 2nd activation control compl. - hose reel
- * Complet. mando 2° activación - enrollador

TAV. SV.03.01 COMPL. ATTIVAZIONE - RACCOGLITUBO (21023 - 23023 P)

- * Compl. activation - serre-tubes
- * Aktivierung - Ergänzung - Schlauchaufnahme
- * Activation compl. - pipe holder
- * Complet. activación - recogetubo

TAV. SV.03.02 COMPL. ATTIVAZIONE - RACCOGLITUBO (21024 - 23024 P)

- * Compl. activation - serre-tubes
- * Aktivierung - Ergänzung - Schlauchaufnahme
- * Activation compl. - pipe holder
- * Complet. activación - recogetubo

TAV. SV.03.03 1/2 COMPL. ATTIVAZIONE - RACCOGLITUBO (21025 - 23025 P)

- * Compl. activation - serre-tubes
- * Aktivierung - Ergänzung - Schlauchaufnahme
- * Activation compl. - pipe holder
- * Complet. activación - recogetubo

TAV. SV.03.03 2/2 COMPL. ATTIVAZIONE - RACCOGLITUBO (21025 - 23025 P)

- * Compl. activation - serre-tubes
- * Aktivierung - Ergänzung - Schlauchaufnahme
- * Activation compl. - pipe holder
- * Complet. activación - recogetubo

TAV. SV.04.01 COMPL. COMANDO 1° ATTIVAZIONE - RACCOGLITUBO (21023 - 23023 P)

- * Compl. commande 1ère activation - serre-tubes
- * 1. Aktivierung Steuerung - Ergänzung - Schlauchaufnahme
- * 1st activation control compl. - pipe holder
- * Complet. mando 1° activación - recogetubo

TAV. SV.04.02 COMPL. COMANDO 1° ATTIVAZIONE - RACCOGLITUBO (21024 - 23024 P)

- * Compl. commande 1ère activation - serre-tubes
- * 1. Aktivierung Steuerung - Ergänzung - Schlauchaufnahme
- * 1st activation control compl. - pipe holder
- * Complet. mando 1° activación - recogetubo



INDICE

* INDEX
* INDEX

* VERZEICHNIS
* INDICE

Ed.
11/2012

21
23 P

TAV. SV.04.03 COMPL. COMANDO 1° ATTIVAZIONE - RACCOGLITUBO (21025 - 23025 P)

- * Compl. commande 1ère activation - serre-tubes
- * 1. Aktivierung Steuerung - Ergänzung - Schlauchaufnahme
- * 1st activation control compl. - pipe holder
- * Complet. mando 1° activación - recogetubo

TAV. SV.04.04 COMPL. COMANDO 1° ATTIVAZIONE - RACCOGLITUBO - 3° PUNTO DI MANOVRA (21023 - 23023 P)

- * Compl. commande 1ère activation - serre-tubes - 3ème point de manœuvre
- * 1. Aktivierung Steuerung - Ergänzung - Schlauchaufnahme - 3. Manöverplatz
- * 1st activation control compl. - pipe holder - 3rd manoeuvre position
- * Complet. mando 1° activación - recogetubo - 3er punto de maniobra

TAV. SV.04.05 COMPL. COMANDO 1° ATTIVAZIONE - RACCOGLITUBO - 3° PUNTO DI MANOVRA (21024 - 23024 P)

- * Compl. commande 1ère activation - serre-tubes - 3ème point de manœuvre
- * 1. Aktivierung Steuerung - Ergänzung - Schlauchaufnahme - 3. Manöverplatz
- * 1st activation control compl. - pipe holder - 3rd manoeuvre position
- * Complet. mando 1° activación - recogetubo - 3er punto de maniobra

TAV. SV.04.06 COMPL. COMANDO 1° ATTIVAZIONE - RACCOGLITUBO - 3° PUNTO DI MANOVRA (21025 - 23025 P)

- * Compl. commande 1ère activation - serre-tubes - 3ème point de manœuvre
- * 1. Aktivierung Steuerung - Ergänzung - Schlauchaufnahme - 3. Manöverplatz
- * 1st activation control compl. - pipe holder - 3rd manoeuvre position
- * Complet. mando 1° activación - recogetubo - 3er punto de maniobra

TAV. SV.05.01 COMPL. COMANDO 2° ATTIVAZIONE - RACCOGLITUBO (21023 - 23023 P)

- * Compl. commande 2ème activation - serre-tubes
- * 2. Aktivierung Steuerung - Ergänzung - Schlauchaufnahme
- * 2nd activation control compl. - pipe holder
- * Complet. mando 2° activación - recogetubo

TAV. SV.05.02 COMPL. COMANDO 2° ATTIVAZIONE - RACCOGLITUBO (21024 - 23024 P)

- * Compl. commande 2ème activation - serre-tubes
- * 2. Aktivierung Steuerung - Ergänzung - Schlauchaufnahme
- * 2nd activation control compl. - pipe holder
- * Complet. mando 2° activación - recogetubo

TAV. SV.05.03 1/2 COMPL. COMANDO 2° ATTIVAZIONE - RACCOGLITUBO (21025 - 23025 P)

- * Compl. commande 2ème activation - serre-tubes
- * 2. Aktivierung Steuerung - Ergänzung - Schlauchaufnahme
- * 2nd activation control compl. - pipe holder
- * Complet. mando 2° activación - recogetubo

TAV. SV.05.03 2/2 COMPL. COMANDO 2° ATTIVAZIONE - RACCOGLITUBO (21025 - 23025 P)

- * Compl. commande 2ème activation - serre-tubes
- * 2. Aktivierung Steuerung - Ergänzung - Schlauchaufnahme
- * 2nd activation control compl. - pipe holder
- * Complet. mando 2° activación - recogetubo

**INDICE**

* INDEX
* INDEX

* VERZEICHNIS
* INDICE

Ed.
11/2012

21
23 P

TAV. SV.05.04 COMPL. COMANDO 2° ATTIVAZIONE - RACCOGLITUBO - 3° PUNTO DI MANOVRA (21023 - 23023 P)

- * Compl. commande 2ème activation - serre-tubes - 3ème point de manoeuvre
- * 2. Aktivierung Steuerung - Ergänzung - Schlauchaufnahme - 3. Manöverplatz
- * 2nd activation control compl. - pipe holder - 3rd manoeuvre position
- * Complet. mando 2° activación - recogetubo - 3er punto de maniobra

TAV. SV.07.01 COMANDO ATTIVAZIONE ARGANO TC1 - TC2 (23 P)

- * Commande activation treuil - TC1-TC2
- * Winde Betätigungssteuerung - TC1-TC2
- * Winch activation control - TC1-TC2
- * Mando activación cabrestante - TC1-TC2

TAV. SV.05.05 COMPL. COMANDO 2° ATTIVAZIONE - RACCOGLITUBO - 3° PUNTO DI MANOVRA (21024 - 23024 P)

- * Compl. commande 2ème activation - serre-tubes - 3ème point de manoeuvre
- * 2. Aktivierung Steuerung - Ergänzung - Schlauchaufnahme - 3. Manöverplatz
- * 2nd activation control compl. - pipe holder - 3rd manoeuvre position
- * Complet. mando 2° activación - recogetubo - 3er punto de maniobra

TAV. SV.07.02 COMANDO ATTIVAZIONE ARGANO P15 (21)

- * Commande activation treuil - P15
- * Winde Betätigungssteuerung - P15
- * Winch activation control - P15
- * Mando activación cabrestante - P15

TAV. SV.05.06 COMPL. COMANDO 2° ATTIVAZIONE - RACCOGLITUBO - 3° PUNTO DI MANOVRA (21025 - 23025 P)

- * Compl. commande 2ème activation - serre-tubes - 3ème point de manoeuvre
- * 2. Aktivierung Steuerung - Ergänzung - Schlauchaufnahme - 3. Manöverplatz
- * 2nd activation control compl. - pipe holder - 3rd manoeuvre position
- * Complet. mando 2° activación - recogetubo - 3er punto de maniobra

TAV. SV.08.01 COMPL. IMPIANTO ARGANO TC1 (STANDARD) (23 P)

- * Compl. installation treuil - TC1 (standard)
- * Winde Anlagebetätigung - TC1 (Standard)
- * Winch system completion - TC1 (standard)
- * Complet. instalación cabrestante TC1 (estándar)

TAV. SV.06.01 COMPL. ATTIVAZIONE - RACCOGLITUBO (LC)

- * Compl. activation - serre-tubes (LC)
- * Aktivierung - Ergänzung - Schlauchaufnahme (LC)
- * Activation compl. - pipe holder (LC)
- * Complet. activación - recogetubo (LC)

TAV. SV.08.02 COMPL. IMPIANTO ARGANO TC1 (LC) (23 P)

- * Compl. installation treuil - TC1 (LC)
- * Winde Anlagebetätigung - TC1 (LC)
- * Winch system completion - TC1 (LC)
- * Complet. instalación cabrestante TC1 (LC)



INDICE

* INDEX
* INDEX

* VERZEICHNIS
* INDICE

Ed.
11/2012

21
23 P

TAV. SV.09.01 **COMPL. IMPIANTO ARGANO TC2 (STANDARD) (23 P)**

- * Compl. installation treuil - TC2 (standard)
- * Winde Anlagebetätigung - TC2 (Standard)
- * Winch system completion - TC2 (standard)
- * Complet. instalación cabrestante TC2 (estándar)

TAV. SV.09.02 **COMPL. IMPIANTO ARGANO TC2 (LC) (21)**

- * Compl. installation treuil - TC2 (LC)
- * Winde Anlagebetätigung - TC2 (LC)
- * Winch system completion - TC2 (LC)
- * Complet. instalación cabrestante TC2 (LC)

TAV. SV.09.03 **COMPL. IMPIANTO ARGANO P15 (21)**

- * Compl. installation treuil - P15
- * Winde Anlagebetätigung - P15
- * Winch system completion - P15
- * Complet. instalación cabrestante - P15

TAV. SV.09.04 **COMPL. IMPIANTO ARGANO P15 (LC) (21)**

- * Compl. installation treuil - P15 (LC)
- * Winde Anlagebetätigung - P15 (LC)
- * Winch system completion - P15 (LC)
- * Complet. instalación cabrestante - P15 (LC)

TAV. SV.10.01 **BOZZELLO TC1 (2 TIRI) (23 P)**

- * Poulie TC1 (2 tractions)
- * TC1 Seilblock (2 Züge)
- * TC1 line block (2 pulls)
- * Poleas TC1 (2 tiros)

TAV. SV.11.01 **BOZZELLO TC2 (1 TIRO) (23 P)**

- * Poulie TC2 (1 traction)
- * TC2 Seilblock (1 Zug)
- * TC2 line block (1 pull)
- * Poleas TC2 (1 tiro)

TAV. SW.01.01 **DISPOSITIVO BLOCCO - LIMITATORE ROTAZIONE**

- * Dispositif blocage - limiteur rotation
- * Sperreeinrichtung - Rotationsbegrenzer
- * Rotation limiting - stopping device
- * Dispositivo bloqueo limitador rotación

TAV. SW.02.01 1/2 **DISPOSITIVI DI SICUREZZA - BHP (21)**

- * Dispositifs de sécurité - BHP
- * Sicherungsvorrichtungen - BHP
- * Safety devices - BHP
- * Dispositivos de seguridad - BHP



INDICE

* INDEX
* INDEX

* VERZEICHNIS
* INDICE

Ed.
11/2012

21
23 P

TAV. SW.02.01 2/2 DISPOSITIVI DI SICUREZZA - BHP (21)

- * Dispositifs de sécurité - BHP
- * Sicherungsvorrichtungen - BHP
- * Safety devices - BHP
- * Dispositivos de seguridad - BHP

TAV. SW.20.01 SICUREZZA APPOGGIO STABILIZZATORI (INTERLOCK)

- * Sécurité appui stabilisateurs (INTERLOCK)
- * Stützeunterlege Sicherung (INTERLOCK)
- * Outriggers bearing security (INTERLOCK)
- * Seguridad pie estabilizadores (INTERLOCK)

TAV. SW.21.01 DISPOSITIVO BLOCCO - LIMITATORE ROTAZIONE - INTERLOCK 3 (23 P)

- * Dispositif blocage - limiteur rotation - INTERLOCK 3
- * Sperreeinrichtung - Rotationsbegrenzer - INTERLOCK 3
- * Rotation limiting - stopping device - INTERLOCK 3
- * Dispositivo bloqueo limitador rotación - INTERLOCK 3

TAV. SW.21.02 DISPOSITIVO BLOCCO - LIMITATORE ROTAZIONE - INTERLOCK 5

- * Dispositif blocage - limiteur rotation - INTERLOCK 5
- * Sperreeinrichtung - Rotationsbegrenzer - INTERLOCK 5
- * Rotation limiting - stopping device - INTERLOCK 5
- * Dispositivo bloqueo limitador rotación - INTERLOCK 5

TAV. SW.22.01 1/2 COMPL. COMANDO MARTINETTO STABILIZZATORE (BRACCI STANDARD) - INTERLOCK 5

- * Compl. commande vérin stabilisateur (bras standard) - INTERLOCK 5
- * Ergänzung des Steuerungs der Stützzyylinder (Standardarme) - INTERLOCK 5
- * Outrigger cylinder control compl. (standard arms) - INTERLOCK 5
- * Complet. mando gato estabilizador(brazos estándar) - INTERLOCK 5

TAV. SW.22.01 2/2 COMPL. COMANDO MARTINETTO STABILIZZATORE (BRACCI STANDARD) - INTERLOCK 5

- * Compl. commande vérin stabilisateur (bras standard) - INTERLOCK 5
- * Ergänzung des Steuerungs der Stützzyylinder (Standardarme) - INTERLOCK 5
- * Outrigger cylinder control compl. (standard arms) - INTERLOCK 5
- * Complet. mando gato estabilizador(brazos estándar) - INTERLOCK 5

TAV. SW.23.01 COMPL. INTERLOCK 3-4 - 3° PUNTO DI MANOVRA

- * Compl. INTERLOCK 3-4 - 3ème point de manœuvre
- * INTERLOCK 3-4 Ergänzung - 3. Manöverplatz
- * Compl. INTERLOCK 3-4 - 3rd manoeuvre position
- * Complet. INTERLOCK 3-4 - 3er punto de maniobra

TAV. SX.01.01 IMPIANTO ELETTRICO - MACCHINA BASE - HYDROCONTROL (MANUALE) (21)

- * Installation électrique - machine standard - HYDROCONTROL (Manuel)
- * Standardmaschine - Elektrischeanlage - HYDROCONTROL (Manuelle)
- * Standard machine - electric system - HYDROCONTROL (Manual)
- * Instalación eléctrica máquina base - HYDROCONTROL (Manual)



INDICE

* INDEX
* INDEX

* VERZEICHNIS
* INDICE

Ed.
11/2012

21
23 P

TAV. SX.01.02 IMP. ELETTRICO EMERGENZA-MACCHINA BASE - HYDROCONTROL (RADIOCOMANDO) - ARGANO - (21)

- * Installation électrique urgence - machine standard - HYDROCONTROL (radiocommande) - treuil
- * Not-Aus Vorrichtung Elektrischeanlage - Standardmaschine - HYDROCONTROL (Fernsteuerung) - Winde
- * Emergency electric system - Standard machine - HYDROCONTROL (radio control) - winch
- * Instalación eléctrica emergencia - máquina base - HYDROCONTROL (radiomando) - cabrestante

TAV. SX.02.01 1/2 IMPIANTO ELETTRICO EMERGENZA- MACCHINA BASE - HYDROCONTROL (ARGANO) (MANUALE) (21)

- * Installation électrique urgence - machine standard - HYDROCONTROL (treuil) (manuel)
- * Not-Aus Vorrichtung Elektrischeanlage - Standardmaschine - HYDROCONTROL (Winde) (Manuelle)
- * Emergency electric system - Standard machine - HYDROCONTROL (winch) (manual)
- * Instalación eléctrica emergencia - máquina base - HYDROCONTROL (cabrestante) (manual)

TAV. SX.02.01 2/2 IMPIANTO ELETTRICO EMERGENZA- MACCHINA BASE - HYDROCONTROL (ARGANO) (MANUALE) (21)

- * Installation électrique urgence - machine standard - HYDROCONTROL (treuil) (manuel)
- * Not-Aus Vorrichtung Elektrischeanlage - Standardmaschine - HYDROCONTROL (Winde) (Manuelle)
- * Emergency electric system - Standard machine - HYDROCONTROL (winch) (manual)
- * Instalación eléctrica emergencia - máquina base - HYDROCONTROL (cabrestante) (manual)

TAV. SX.02.02 1/2 IMPIANTO ELETTRICO EMERGENZA- MACCHINA BASE - HYDROCONTROL (ARGANO) (RADIOCOMANDO) (21)

- * Installation électrique urgence - machine standard - HYDROCONTROL (treuil) (radiocommande)
- * Not-Aus Vorrichtung Elektrischeanlage - Standardmaschine - HYDROCONTROL (Winde) (Fernsteuerung)
- * Emergency electric system - Standard machine - HYDROCONTROL (winch) (radio control)
- * Instalación eléctrica emergencia - máquina base - HYDROCONTROL (cabrestante) (radiomando)

TAV. SX.02.02 2/2 IMPIANTO ELETTRICO EMERGENZA- MACCHINA BASE - HYDROCONTROL (ARGANO) (RADIOCOMANDO) (21)

- * Installation électrique urgence - machine standard - HYDROCONTROL (treuil) (radiocommande)
- * Not-Aus Vorrichtung Elektrischeanlage - Standardmaschine - HYDROCONTROL (Winde) (Fernsteuerung)
- * Emergency electric system - Standard machine - HYDROCONTROL (winch) (radio control)
- * Instalación eléctrica emergencia - máquina base - HYDROCONTROL (cabrestante) (radiomando)

TAV. SX.02.03 1/2 IMPIANTO ELETTRICO EMERGENZA- MACCHINA BASE - DANFOSS (ARGANO) (21)

- * Installation électrique urgence - machine standard - DANFOSS (treuil)
- * Not-Aus Vorrichtung Elektrischeanlage - Standardmaschine - DANFOSS (Winde)
- * Emergency electric system - Standard machine - DANFOSS (winch)
- * Instalación eléctrica emergencia - máquina base - DANFOSS (cabrestante)

TAV. SX.02.03 2/2 IMPIANTO ELETTRICO EMERGENZA- MACCHINA BASE - DANFOSS (ARGANO) (21)

- * Installation électrique urgence - machine standard - DANFOSS (treuil)
- * Not-Aus Vorrichtung Elektrischeanlage - Standardmaschine - DANFOSS (Winde)
- * Emergency electric system - Standard machine - DANFOSS (winch)
- * Instalación eléctrica emergencia - máquina base - DANFOSS (cabrestante)

TAV. SX.03.01 1/2 IMPIANTO ELETTRICO - MACCHINA BASE (23 P)

- * Installation électrique - machine standard
- * Standardmaschine - Elektrischeanlage
- * Standard machine - electric system
- * Instalación eléctrica máquina base



INDICE

* INDEX
* INDEX

* VERZEICHNIS
* INDICE

Ed.
11/2012

21
23 P

TAV. SX.03.01A 1/2 IMPIANTO ELETTRICO - MACCHINA BASE - LG-A (23 P)

- * Installation électrique - machine standard - LG-A
- * Standardmaschine - Elektrischeanlage - LG-A
- * Standard machine - electric system - LG-A
- * Instalación eléctrica máquina base - LG-A

TAV. SX.03.01 2/2 IMPIANTO ELETTRICO - MACCHINA BASE (23 P)

- * Installation électrique - machine standard
- * Standardmaschine - Elektrischeanlage
- * Standard machine - electric system
- * Instalación eléctrica máquina base

TAV. SX.04.01 IMPIANTO ELETTRICO - PROLUNGA ARTICOLATA (23 P)

- * Installation électrique - rallonge articulée
- * Gelenkverlängerung - Elektrischeanlage
- * Jib - electric system
- * Instalación eléctrica extensión articulada

TAV. SX.05.01 IMPIANTO ELETTRICO ARGANO (23 P)

- * Installation électrique treuil
- * Windeelektrischeanlage
- * Winch electric system
- * Instalación eléctrica cabrestante

TAV. SX.06.01 IMPIANTO ELETTRICO ARGANO - PROLUNGA ARTICOLATA (23 P)

- * Installation électrique treuil - rallonge articulée
- * Winde - Gelenkverlängerung Elektrischeanlage
- * Winch - jib - electric system
- * Instalación eléctrica cabrestante - extensión articulada

TAV. SX.06.02 IMPIANTO ELETTRICO ARGANO TC1 - PROLUNGA ARTICOLATA (23 P)

- * Installation électrique treuil TC1 - rallonge articulée
- * TC1 Winde - Gelenkverlängerung Elektrischeanlage
- * TC1 winch - jib - electric system
- * Instalación eléctrica cabrestante TC1 - extensión articulada

TAV. SX.07.01 IMPIANTO ELETTRICO STABILIZZATORI "MCS" (23 P)

- * Installation électrique stabilisateurs "MCS"
- * Stützeelektrischeanlage "MCS"
- * Outriggers electric system "MCS"
- * Instalación eléctrica estabilizadores "MCS"

TAV. SX.08.01 SCAMBIATORE DI CALORE - HYDROCONTROL (MANUALE) (21)

- * Echangeur chaleur - HYDROCONTROL (manuel)
- * Wärmeaustauscher - HYDROCONTROL (manuelle)
- * Heat exchanger - HYDROCONTROL (manual)
- * Intercambiador calor - HYDROCONTROL (manual)



INDICE

* INDEX
* INDEX

* VERZEICHNIS
* INDICE

Ed.
11/2012

21
23 P

TAV. SX.08.02 SCAMBIATORE DI CALORE - DANFOSS - HYDROCONTROL (RADIOCOMANDO)

- * Echangeur chaleur - DANFOSS -HYDROCONTROL (radiocommande)
- * Wärmeaustauscher - DANFOSS -HYDROCONTROL (Fernsteuerung)
- * Heat exchanger - DANFOSS -HYDROCONTROL (radio control)
- * Intercambiador calor - DANFOSS -HYDROCONTROL (radio mando)

TAV. SY.02.01 RADIOCOMANDO HTR 6F CE STD/INV (240247) (23 P)

- * Radiocommande HTR 6F CE STD/INV (240247)
- * Funksteuerung HTR 6F CE STD/INV (240247)
- * Radio control HTR 6F CE STD/INV (240247)
- * Radiocontrol HTR 6F CE STD/INV (240247)

TAV. SX.09.01 SERBATOIO OLIO - 3° PUNTO DI MANOVRA

- * Réservoir d'huile - 3ème point de manœuvre
- * Ölbehälter - 3. Manöverplatz
- * Oil tank - 3rd manoeuvre position
- * Deposito aceite - 3er punto de maniobra

TAV. SY.02.02 RADIOCOMANDO HTR 6F USA STD/INV (270592) (23 P)

- * Radiocommande HTR 6F USA STD/INV (270592)
- * Funksteuerung HTR 6F USA STD/INV (270592)
- * Radio control HTR 6F USA STD/INV (270592)
- * Radiocontrol HTR 6F USA STD/INV (270592)

TAV. SY.01.01 RADIOCOMANDO - SCANRECO 6F (397001) - DANFOSS (21)

- * Radiocommande - SCANRECO 6F - DANFOSS
- * Funksteuerung - SCANRECO 6F - DANFOSS
- * Radio control - SCANRECO 6F - DANFOSS
- * Radiocontrol - SCARECO 6F - DANFOSS

TAV. SY.01.02 RADIOCOMANDO - SCANRECO 6F (470491) - STD (23 P)

- * Radiocommande - SCANRECO 6F (470491) - STD
- * Funksteuerung - SCANRECO 6F (470491) - STD
- * Radio control - SCANRECO 6F (470491) - STD
- * Radiocontrol - SCARECO 6F (470491) - STD

MACCHINA BASE

GRUE STANDARD

STANDARDKРАН

BASIC CRANE

GRUA BASE



BASE - ANCORAGGIO

* Embase - ancrage
* Kranfuß - Befestigungssatz
* Base - anchorage kit
* Base - kit de anclaje

TAV. GA.01.01

matr. G107.0005

21
23 P

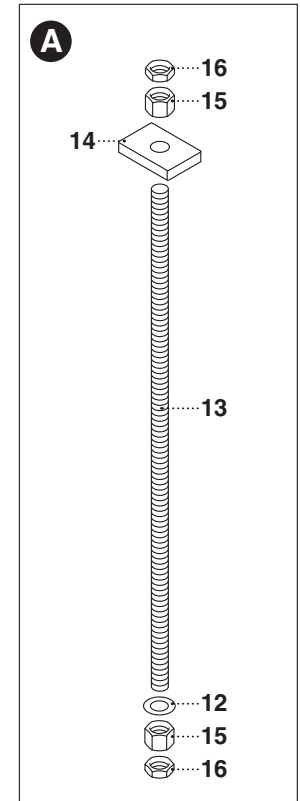
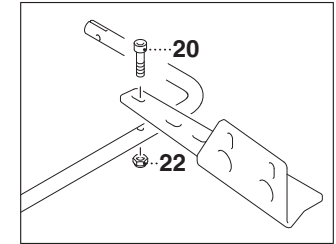
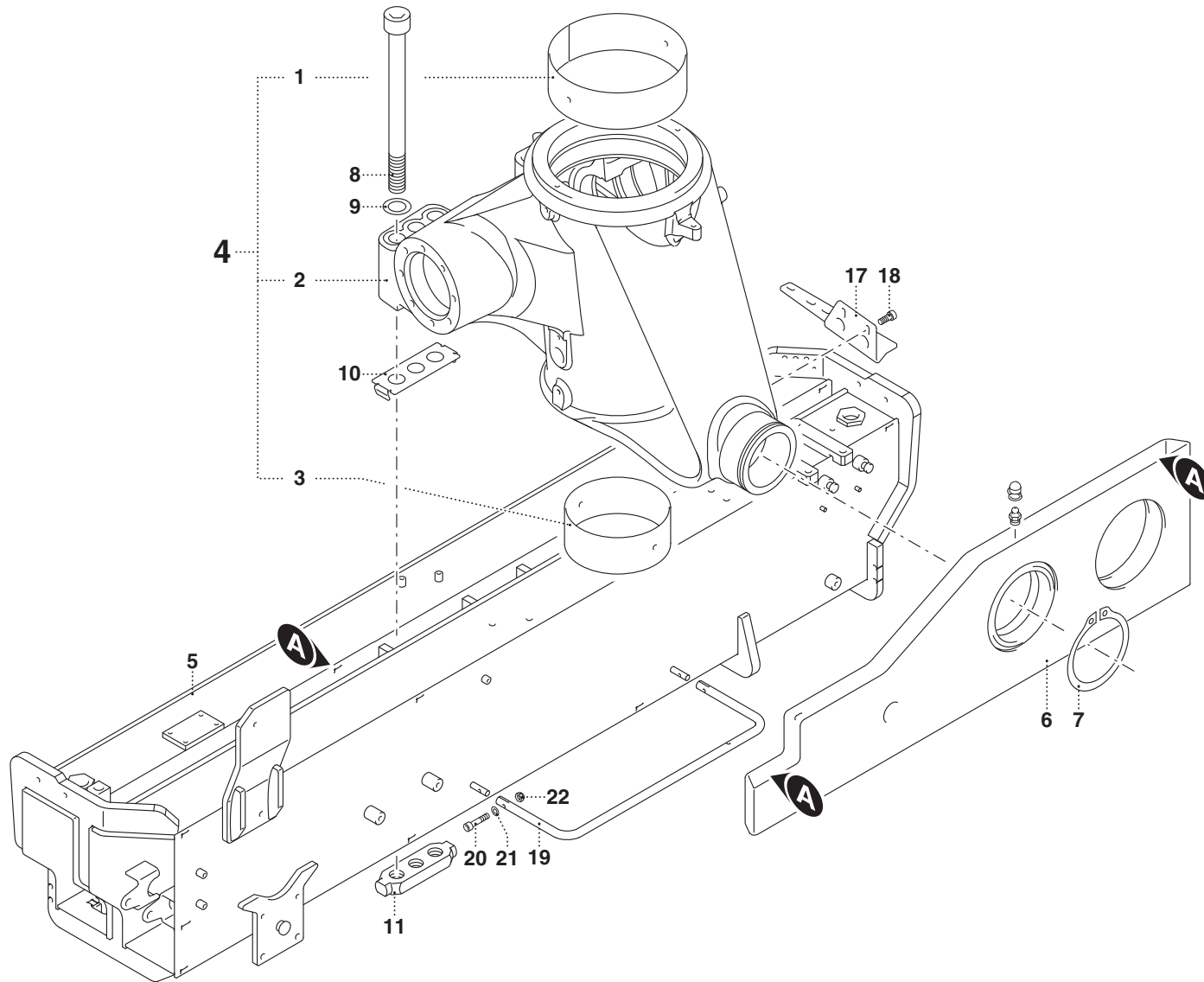
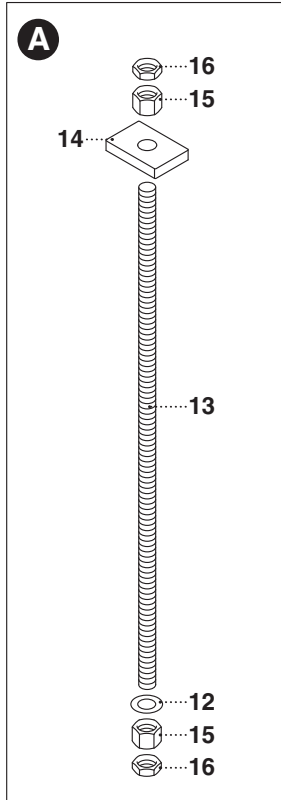

PM 21 - PM 23 P

matr. G107.0005

TAV. GA.01.01

POS.	N° CODICE	Q.	DESCRIZIONE	DESIGNATION	BENENNUNG	DESCRIPTION	DENOMINACIONES
1	137388	1	BOCCOLA	DOUILLE	BUCHSE	BUSHING	CASQUILLO
2	467444	1	SUPPORTO	SUPPORT	TRÄGER	SUPPORT	SOPORTE
3	137351	1	BOCCOLA	DOUILLE	BUCHSE	BUSHING	CASQUILLO
4	280980	1	KIT SUPPORTO ROTAZIONE	KIT SUPPORT ROTATION	ROTATIONTRÄGERSATZ	ROTATION SUPPORT KIT	KIT SOPORTE ROTACION
5	120945	1	TRAVERSA	TRAVERSE	QUERBALKEN	CROSSBEAM	TRAVIESA
6	467488	1	SUPPORTO	SUPPORT	TRÄGER	SUPPORT	SOPORTE
7	109193	1	ANELLO ELASTICO	JOINT D'ARRET	SPRENGRING	SPRING RING	ANILLO ELASTICO
8	497487	6	VITE	VIS	SCHRAUBE	SCREW	TORNILLO
9	417212	6	RONDELLA	RONDELLE	SCHEIBE	WASHER	ARANDELA
10	373905	2	PATTINO	PATIN	GLEITBLOCK	SLIDING BLOCK	PATIN
11	459157	2	STAFFA	ETRIER	BÜGEL	BRACKET	ESTRIBO
12	417175	12	RONDELLA	RONDELLE	SCHEIBE	WASHER	ARANDELA
13	481189	6	TIRANTE	TIRANT	ZUGSTANGE	TIE ROD	TIRANTE
14	459066	6	STAFFA	ETRIER	BÜGEL	BRACKET	ESTRIBO
15	191173	12	DADO	ECROU	MUTTER	NUT	TUERCA
16	191087	12	DADO	ECROU	MUTTER	NUT	TUERCA
17	467506	1	SUPPORTO	SUPPORT	TRÄGER	SUPPORT	SOPORTE
18	497130	2	VITE	VIS	SCHRAUBE	SCREW	TORNILLO
19	467588	1	SUPPORTO	SUPPORT	TRÄGER	SUPPORT	SOPORTE
20	497121	3	VITE	VIS	SCHRAUBE	SCREW	TORNILLO
21	417024	3	RONDELLA	RONDELLE	SCHEIBE	WASHER	ARANDELA
22	191125	3	DADO	ECROU	MUTTER	NUT	TUERCA



ROTAZIONE

- * Rotation
- * Drehung
- * Rotación
- * Rotación

TAV. GA.02.01

matr. G107.0005

21
23 P

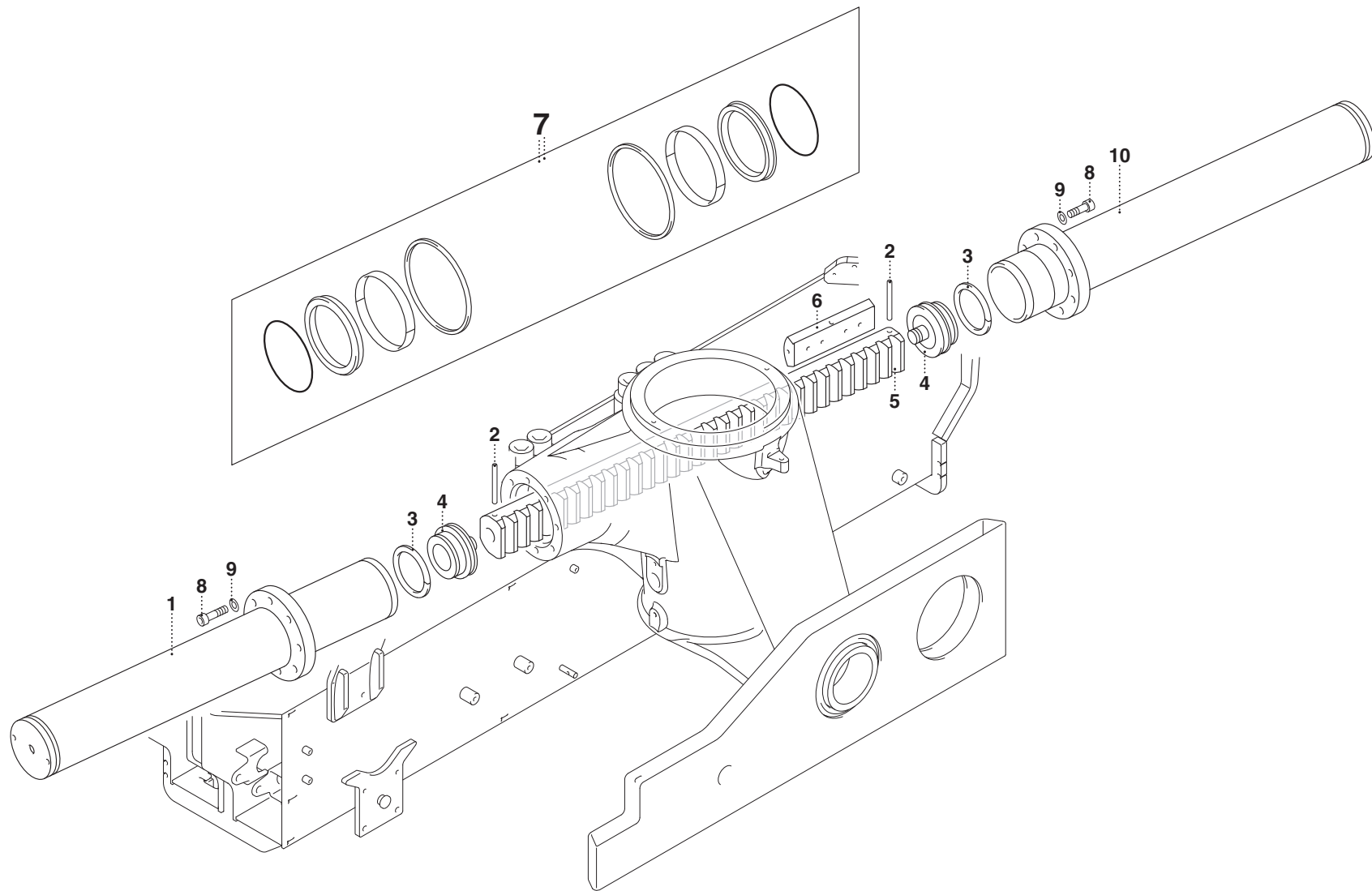

PM 21 - PM 23 P

matr. G107.0005

TAV. GA.02.01

POS.	N° CODICE	Q.	DESCRIZIONE	DESIGNATION	BENENNUNG	DESCRIPTION	DENOMINACIONES
1	161837	1	CILINDRO	CYLINDRE	ZYLINDER	CYLINDER	CILINDRO
2	455716	2	SPINA	GOUPILLE	STIFT	PIN	PASADOR
3	112060	2	ANELLO	BAGUE	RING	RING	ANILLO
4	382368	2	PISTONE	PISTON	KOLBEN	PISTON	PISTON
5	181058	1	CREMAGLIERA	CREMAILLERE	ZAHNSTANGE	RACK	CREMALLERA
6	373929	1	PATTINO	PATIN	GLEITBLOCK	SLIDING BLOCK	PATIN
7	280662	1	KIT GUARNIZIONI	KIT JOINTS	DICHTUNGSSATZ	SEALS KIT	KIT JUNTAS
8	497881	16	VITE	VIS	SCHRAUBE	SCREW	TORNILLO
9	417007	16	RONDELLA	RONDELLE	SCHEIBE	WASHER	ARANDELA
10	161838	1	CILINDRO	CYLINDRE	ZYLINDER	CYLINDER	CILINDRO



BRACCI STABILIZZATORI STANDARD - SFILO MANUALE

* Bras stabilisateurs standard - extension manuelle
* Standardstützarme - manuelle Ausziehen
* Standard outrigger arms - manual extension
* Brazos estabiliz. estándar - extensión manual

TAV. GB.01.01

matr. G107.0005

21
23 P

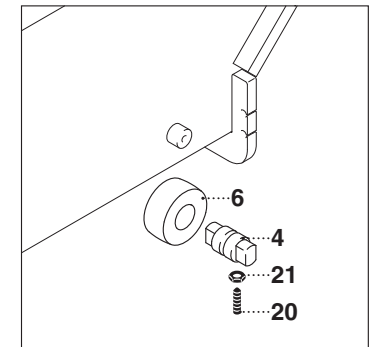
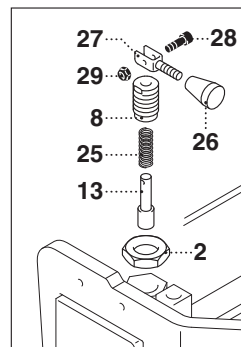
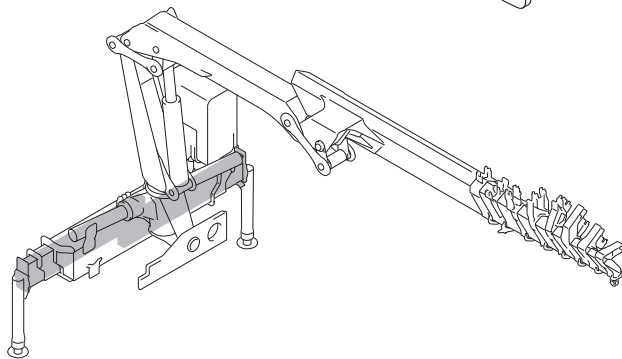
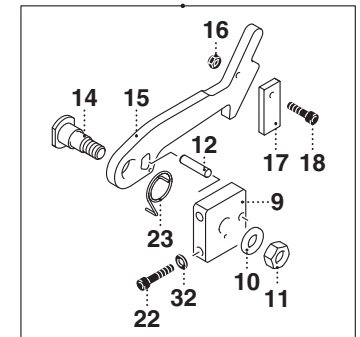
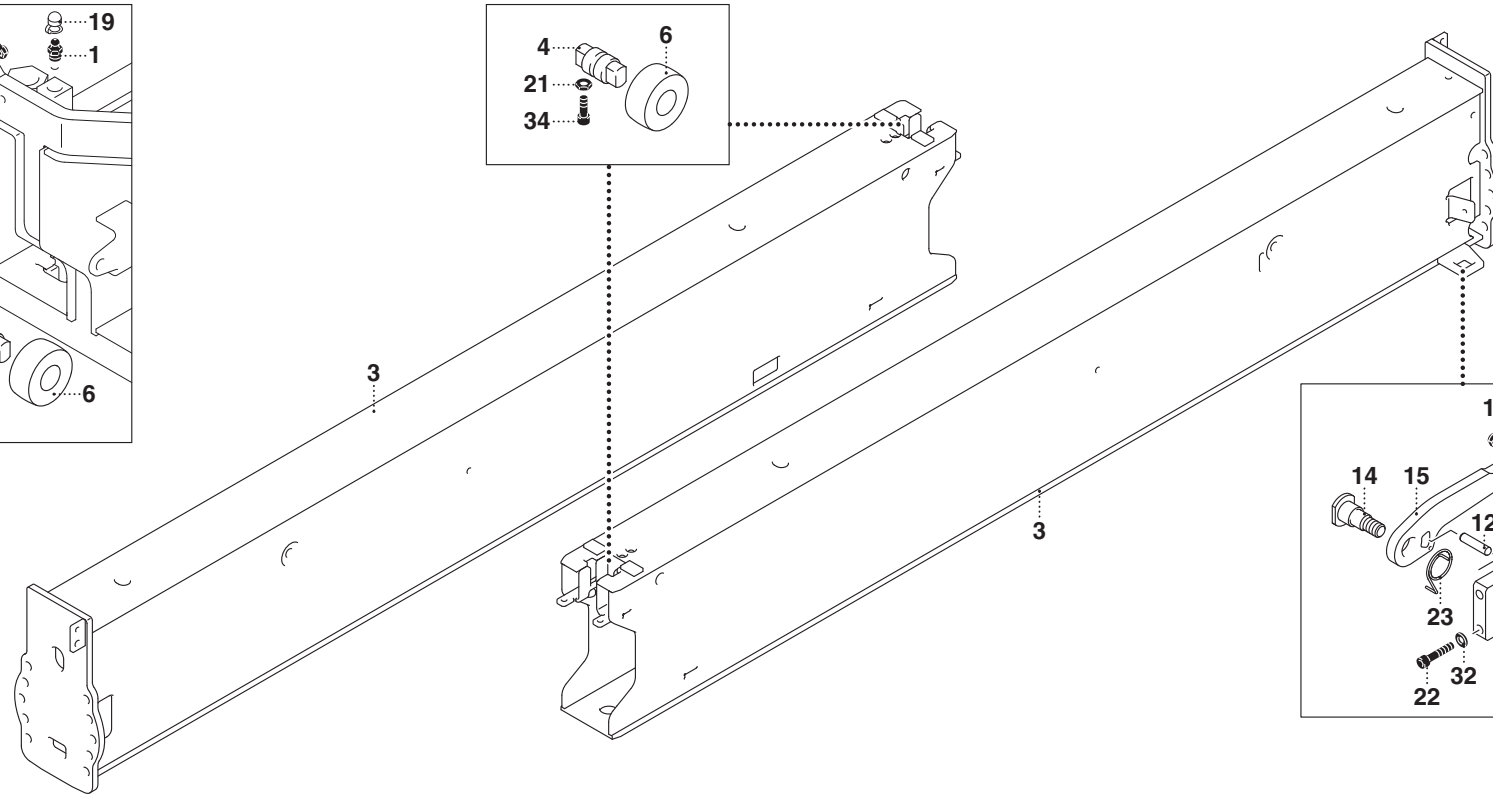
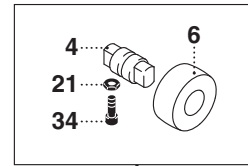
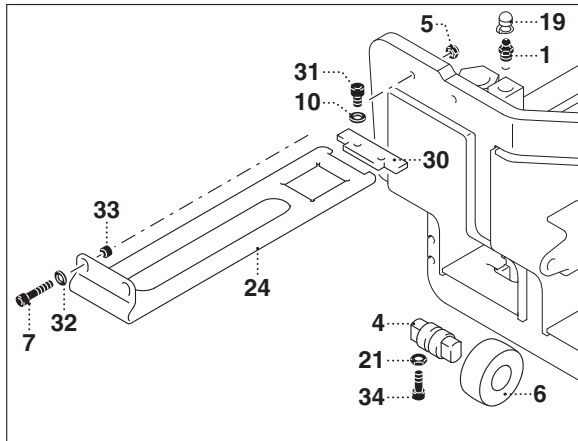

UN01-R-1529-LG

PM 21 - PM 23 P

matr. G107.0005

TAV. GB.01.01

POS.	N° CODICE	Q.	DESCRIZIONE	DESIGNATION	BENENNUNG	DESCRIPTION	DENOMINACIONES
1	281010	2	INGRASSATORE	GRAISSEUR	SCHMIERER	GREASE FITTING	ENGRASADOR
2	191087	2	DADO	ECROU	MUTTER	NUT	TUERCA
3	142515	2	BRACCIO STABILIZZATORE	BRAS STABILISATEUR	STABILISATORARM	STABILISATOR ARM	BRAZO ESTABILIZADOR
4	379949	4	PERNO	AXE	BOLZEN	PIN	PERNO
5	191168	4	DADO	ECROU	MUTTER	NUT	TUERCA
6	429010	4	RULLO	GALET	ROLLE	ROLLER	RODILLO
7	497135	4	VITE	VIS	SCHRAUBE	SCREW	TORNILLO
8	136915	2	BOCCOLA	DOUILLE	BUCHSE	BUSHING	CASQUILLO
9	466552	2	SUPPORTO	SUPPORT	TRÄGER	SUPPORT	SOPORTE
10	417005	6	RONDELLA	RONDELLE	SCHEIBE	WASHER	ARANDELA
11	191045	2	DADO	ECROU	MUTTER	NUT	TUERCA
12	455023	2	SPINA	GOUPILLE	STIFT	PIN	PASADOR
13	380479	2	PERNO	AXE	BOLZEN	PIN	PERNO
14	380229	2	PERNO	AXE	BOLZEN	PIN	PERNO
15	208287	2	FERMO	ARRET	VERSTELLVORRICHTUNG	LOCK	TOPE
16	191033	2	DADO	ECROU	MUTTER	NUT	TUERCA
17	208288	2	FERMO	ARRET	VERSTELLVORRICHTUNG	LOCK	TOPE
18	497111	2	VITE	VIS	SCHRAUBE	SCREW	TORNILLO
19	471215	2	TAPPO	BOUCHON	VERSCHLUSSDECKEL	PLUG	TAPON
20	498103	4	VITE	VIS	SCHRAUBE	SCREW	TORNILLO
21	191064	8	DADO	ECROU	MUTTER	NUT	TUERCA
22	497134	4	VITE	VIS	SCHRAUBE	SCREW	TORNILLO
23	349130	2	MOLLA	RESSORT	FEDER	SPRING	MUELLE
24	373906	2	PATTINO	PATIN	GLEITBLOCK	SLIDING BLOCK	PATIN
25	349090	2	MOLLA	RESSORT	FEDER	SPRING	MUELLE
26	385007	2	POMELLO	POMMEAU	KNOPF	KNOB	POMO



BRACCI STABILIZZATORI STANDARD - SFILO MANUALE

* Bras stabilisateurs standard - extension manuelle
* Standardstützarme - manuelle Ausziehen
* Standard outrigger arms - manual extension
* Brazos estabiliz. estándar - extensión manual

TAV. GB.01.01

matr. G107.0005

21
23 P

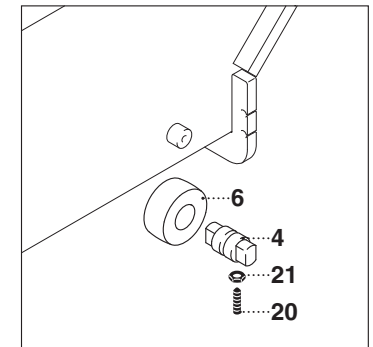
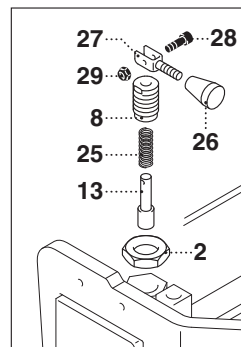
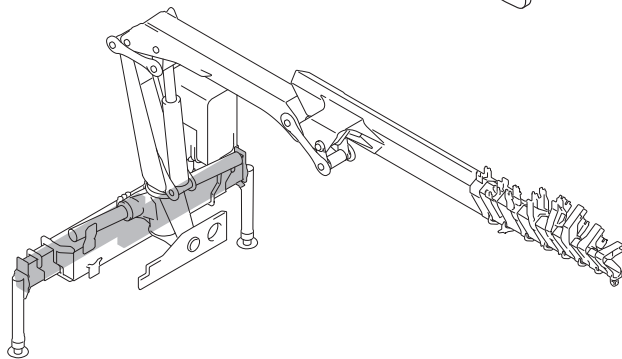
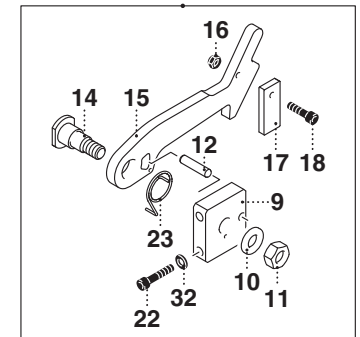
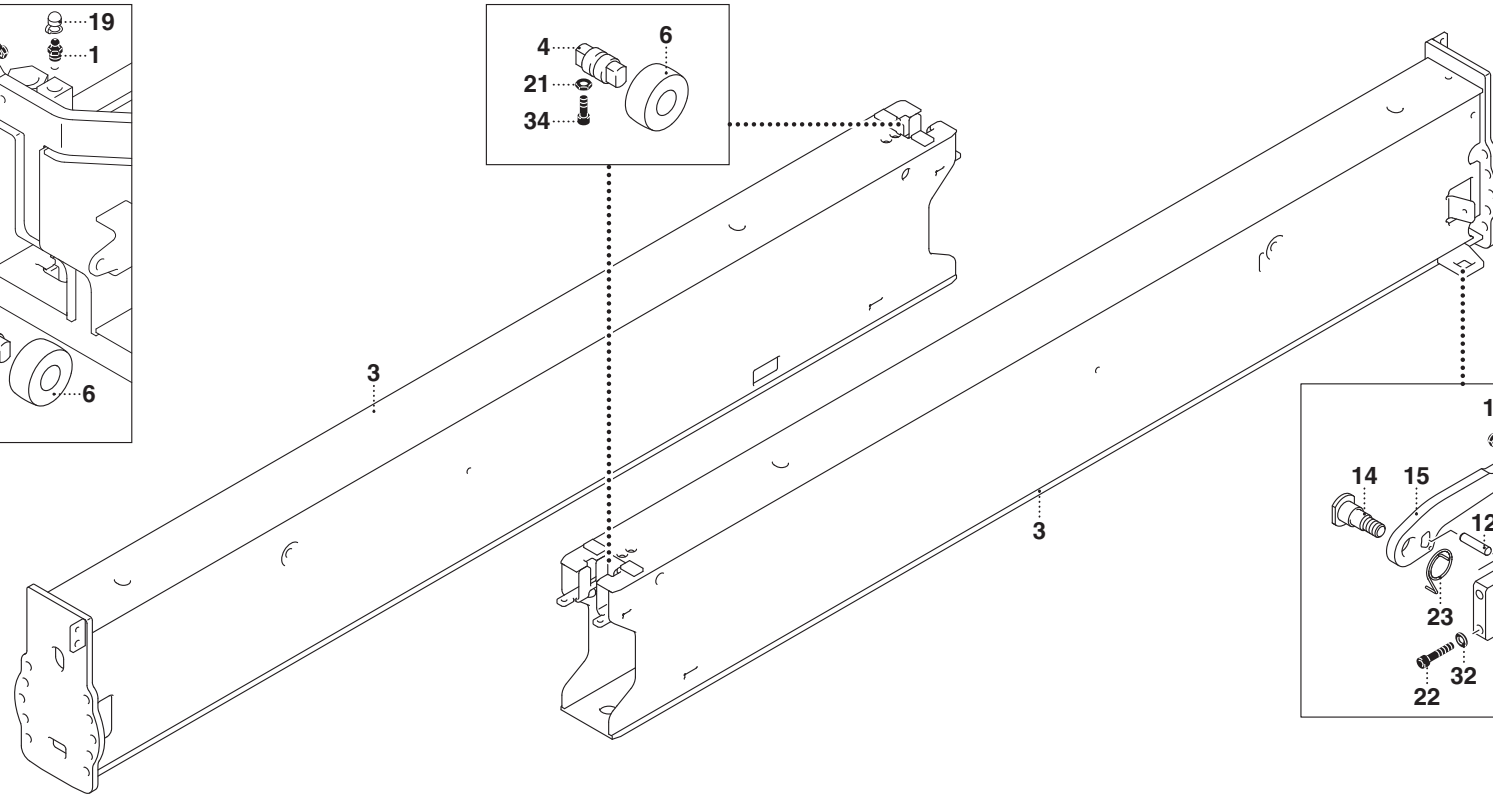
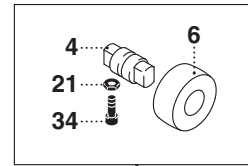
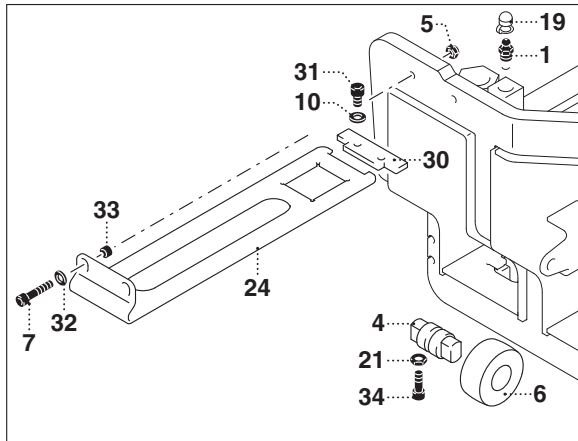

UN01-R-1529-LG

PM 21 - PM 23 P

matr. G107.0005

TAV. GB.01.01

POS. N° CODICE	Q.	DESCRIZIONE	DESIGNATION	BENENNUNG	DESCRIPTION	DENOMINACIONES	
27	220044	2	FORCELLA	FOURCHE	GABEL	CLEVIS	HORQUILLA
28	497114	2	VITE	VIS	SCHRAUBE	SCREW	TORNILLO
29	191046	2	DADO	ECROU	MUTTER	NUT	TUERCA
30	208295	2	FERMO	ARRET	VERSTELLVORRICHTUNG	LOCK	TOPE
31	497143	4	VITE	VIS	SCHRAUBE	SCREW	TORNILLO
32	417004	8	RONDELLA	RONDELLE	SCHEIBE	WASHER	ARANDELA
33	136934	4	BOCCOLA	DOUILLE	BUCHSE	BUSHING	CASQUILLO
34	497148	4	VITE	VIS	SCHRAUBE	SCREW	TORNILLO



BRACCI STABILIZZATORI STANDARD - SFILO IDRAULICO

- * Bras stabilisateurs standard - extension hydraulique
- * Standardstützarme - hydraulische Ausziehen
- * Standard outrigger arms - hydraulic extension
- * Brazos estabiliz. estándar - extensión hidráulica

TAV. GB.01.02

matr. G107.0005

21
23 P

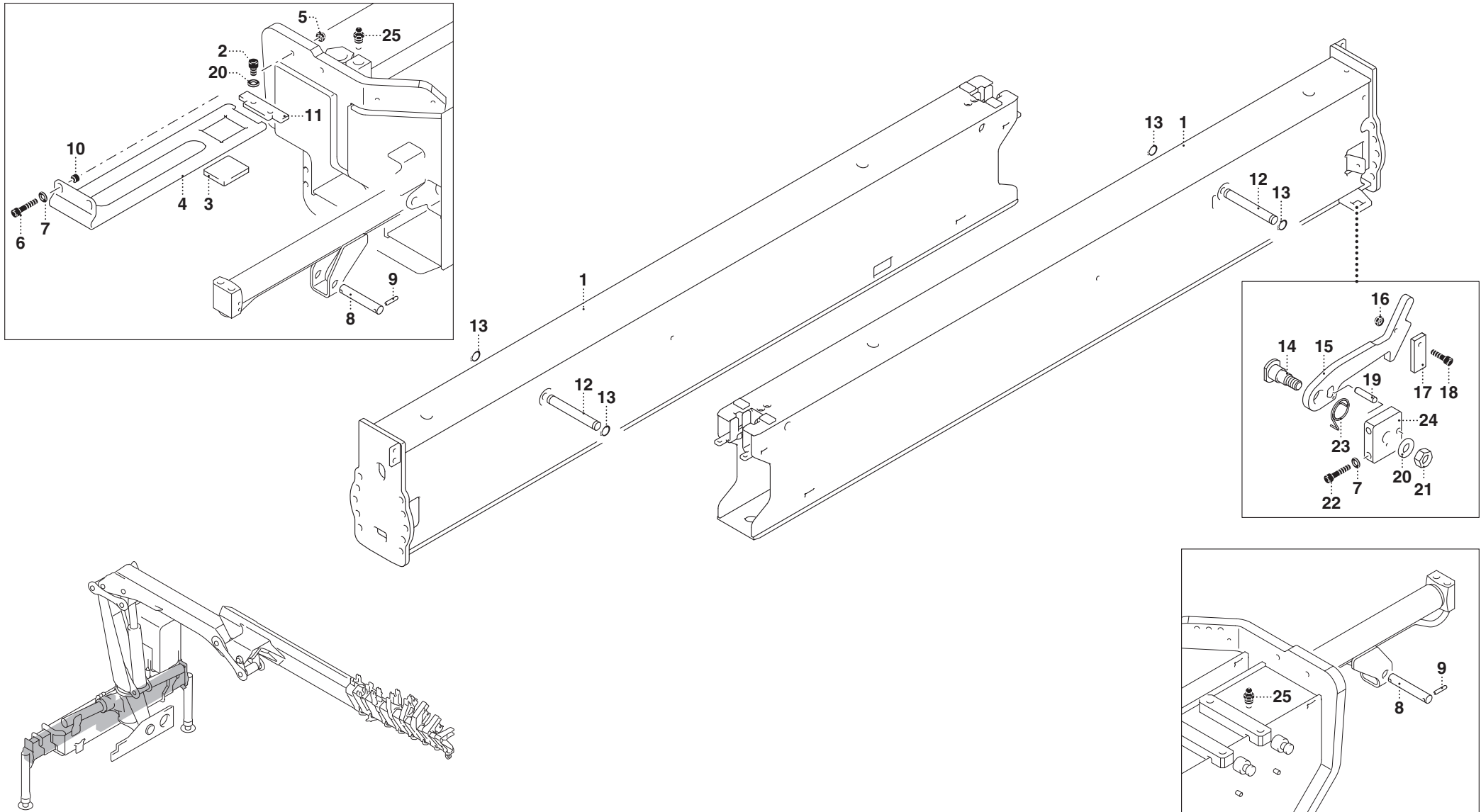

UN01-R-1541-LG

PM 21 - PM 23 P

matr. G107.0005

TAV. GB.01.02

POS.	N° CODICE	Q.	DESCRIZIONE	DESIGNATION	BENENNUNG	DESCRIPTION	DENOMINACIONES
1	142515	2	BRACCIO	BRAS	ARM	ARM	BRAZO
2	497143	4	VITE	VIS	SCHRAUBE	SCREW	TORNILLO
3	373907	2	PATTINO	PATIN	GLEITBLOCK	SLIDING BLOCK	PATIN
4	373906	2	PATTINO	PATIN	GLEITBLOCK	SLIDING BLOCK	PATIN
5	191168	4	DADO	ECROU	MUTTER	NUT	TUERCA
6	497135	4	VITE	VIS	SCHRAUBE	SCREW	TORNILLO
7	417004	8	RONDELLA	RONDELLE	SCHEIBE	WASHER	ARANDELA
8	380423	2	PERNO	AXE	BOLZEN	PIN	PERNO
9	455212	4	SPINA	GOUPILLE	STIFT	PIN	PASADOR
10	136934	4	BOCCOLA	DOUILLE	BUCHSE	BUSHING	CASQUILLO
11	208295	2	FERMO	ARRET	VERSTELLVORRICHTUNG	LOCK	TOPE
12	380460	2	PERNO	AXE	BOLZEN	PIN	PERNO
13	109006	4	ANELLO	BAGUE	RING	RING	ANILLO
14	380229	2	PERNO	AXE	BOLZEN	PIN	PERNO
15	208287	2	FERMO	ARRET	VERSTELLVORRICHTUNG	LOCK	TOPE
16	191033	2	DADO	ECROU	MUTTER	NUT	TUERCA
17	208288	2	FERMO	ARRET	VERSTELLVORRICHTUNG	LOCK	TOPE
18	497111	2	VITE	VIS	SCHRAUBE	SCREW	TORNILLO
19	455023	2	SPINA	GOUPILLE	STIFT	PIN	PASADOR
20	417005	10	RONDELLA	RONDELLE	SCHEIBE	WASHER	ARANDELA
21	191206	2	DADO	ECROU	MUTTER	NUT	TUERCA
22	497134	4	VITE	VIS	SCHRAUBE	SCREW	TORNILLO
23	349130	2	MOLLA	RESSORT	FEDER	SPRING	MUELLE
24	466552	2	SUPPORTO	SUPPORT	TRÄGER	SUPPORT	SOPORTE
25	281010	2	INGRASSATORE	GRAISSEUR	SCHMIERER	GREASE FITTING	ENGRASADOR



BRACCI STABILIZZATORI SUPER EXTRALARGHI

* Bras stabilisateurs super extra larges
* Superextrabreitestützarme
* Super extra-large outrigger arms
* Brazos estabiliz. super extra-anchos

TAV. GB.01.03 1/2

matr. G107.0005

21
23 P

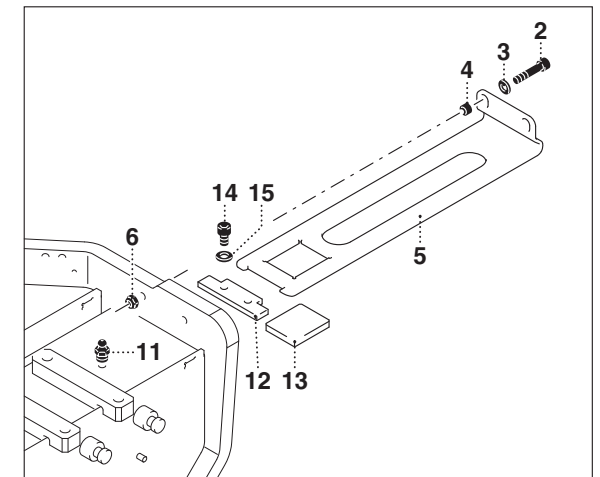
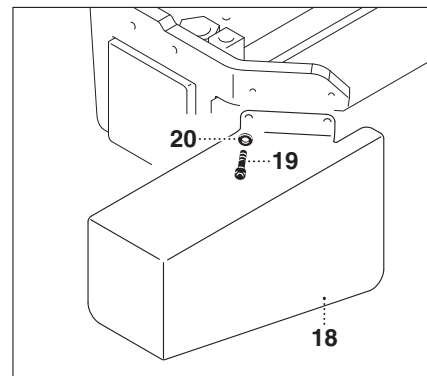
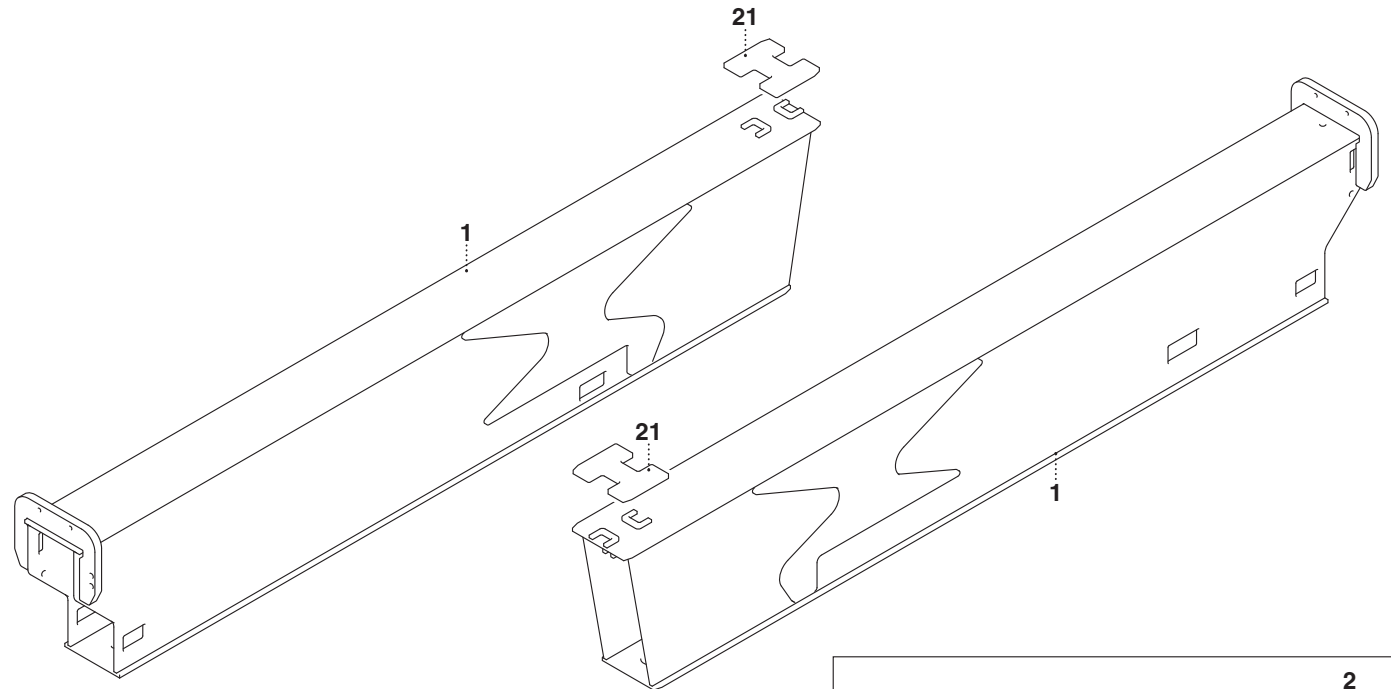
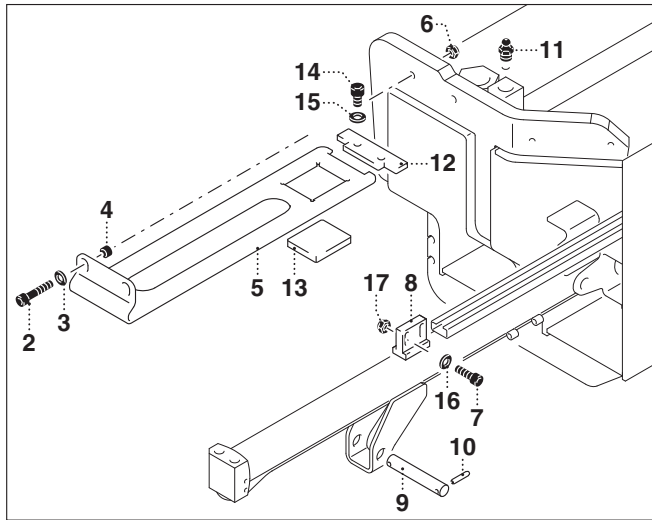

UN01-R-1445-LG

PM 21 - PM 23 P

matr. G107.0005

TAV. GB.01.03 1/2

POS.	N° CODICE	Q.	DESCRIZIONE	DESIGNATION	BENENNUNG	DESCRIPTION	DENOMINACIONES
1	142507	2	BRACCIO	BRAS	ARM	ARM	BRAZO
2	497135	4	VITE	VIS	SCHRAUBE	SCREW	TORNILLO
3	417004	4	RONDELLA	RONDELLE	SCHEIBE	WASHER	ARANDELA
4	136934	4	BOCCOLA	DOUILLE	BUCHSE	BUSHING	CASQUILLO
5	373906	2	PATTINO	PATIN	GLEITBLOCK	SLIDING BLOCK	PATIN
6	191168	4	DADO	ECROU	MUTTER	NUT	TUERCA
7	491121	4	VITE	VIS	SCHRAUBE	SCREW	TORNILLO
8	373932	2	PATTINO	PATIN	GLEITBLOCK	SLIDING BLOCK	PATIN
9	380423	2	PERNO	AXE	BOLZEN	PIN	PERNO
10	455212	4	SPINA	GOUPILLE	STIFT	PIN	PASADOR
11	281010	2	INGRASSATORE	GRAISSEUR	SCHMIERER	GREASE FITTING	ENGRASADOR
12	208295	2	FERMO	ARRET	VERSTELLVORRICHTUNG	LOCK	TOPE
13	373907	2	PATTINO	PATIN	GLEITBLOCK	SLIDING BLOCK	PATIN
14	497143	4	VITE	VIS	SCHRAUBE	SCREW	TORNILLO
15	417005	8	RONDELLA	RONDELLE	SCHEIBE	WASHER	ARANDELA
16	417025	4	RONDELLA	RONDELLE	SCHEIBE	WASHER	ARANDELA
17	191125	4	DADO	ECROU	MUTTER	NUT	TUERCA
18	176417	2	CARTER	CARTER	GEHÄUSE	CASING	CARTER
19	497120	4	VITE	VIS	SCHRAUBE	SCREW	TORNILLO
20	417024	4	RONDELLA	RONDELLE	SCHEIBE	WASHER	ARANDELA
21	373949	2	PATTINO	PATIN	GLEITBLOCK	SLIDING BLOCK	PATIN



BRACCI STABILIZZATORI SUPER EXTRALARGHI

- * Bras stabilisateurs super extra larges
- * Superextrabreitestützarme
- * Super extra-large outrigger arms
- * Brazos estabiliz. super extra-anchos

TAV. GB.01.03 2/2

matr. G107.0005

21
23 P

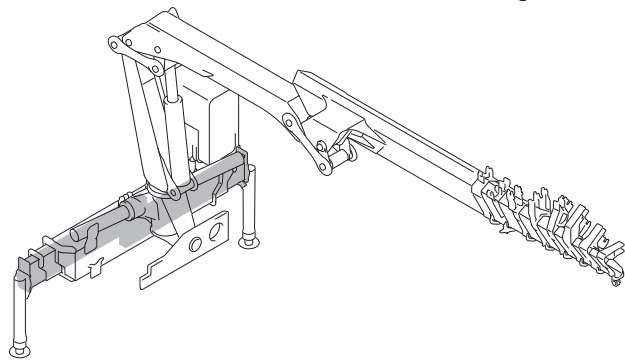
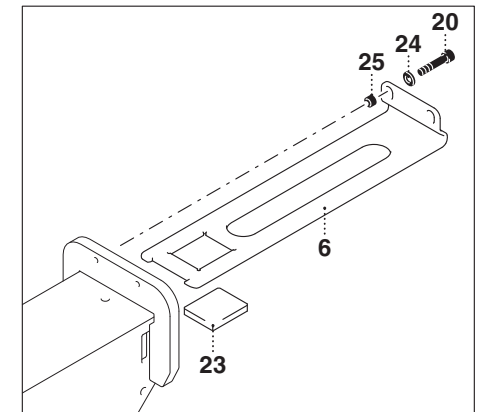
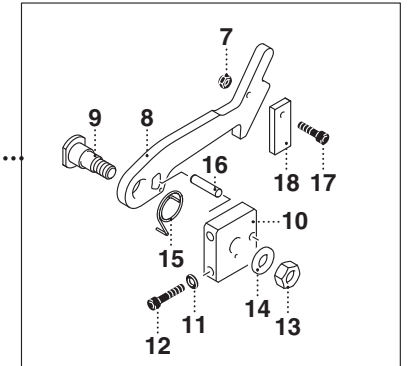
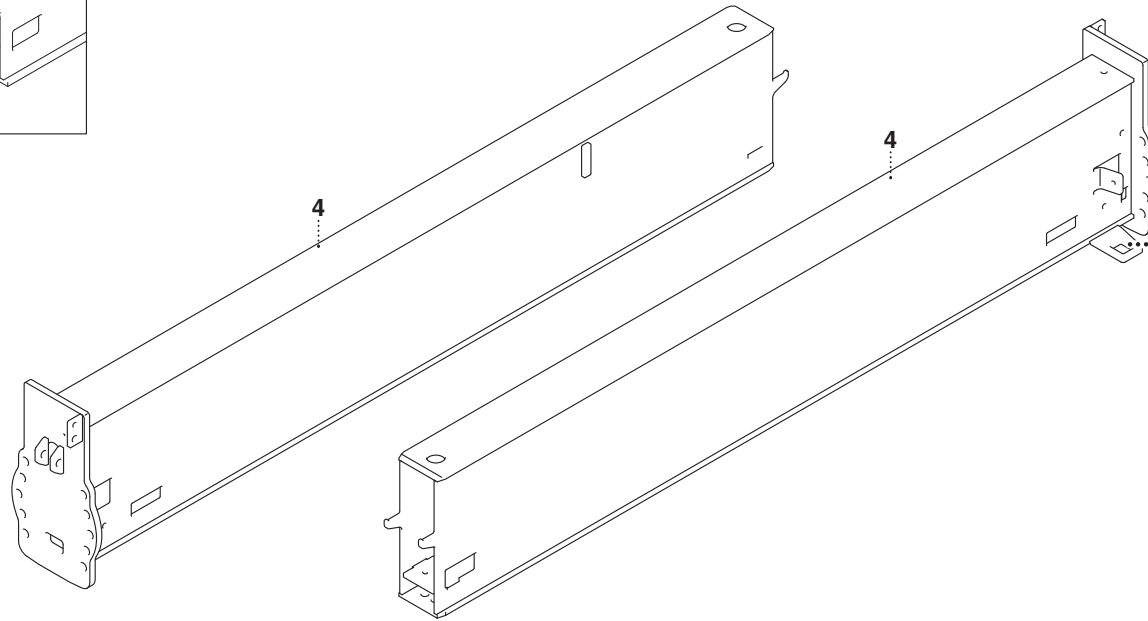
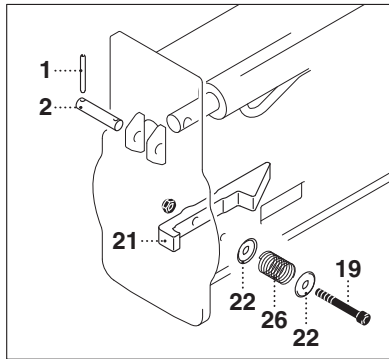
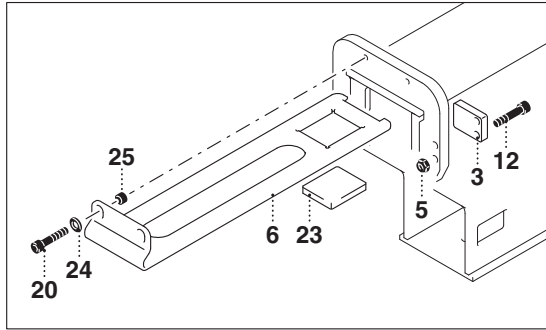

UN01-R-1491-LG

PM 21 - PM 23 P

matr. G107.0005

TAV. GB.01.03 2/2

POS.	N° CODICE	Q.	DESCRIZIONE	DESIGNATION	BENENNUNG	DESCRIPTION	DENOMINACIONES
1	380438	2	PERNO	AXE	BOLZEN	PIN	PERNO
2	455212	4	SPINA	GOUPILLE	STIFT	PIN	PASADOR
3	208277	2	FERMO	ARRET	VERSTELLVORRICHTUNG	LOCK	TOPE
4	142508	2	BRACCIO	BRAS	ARM	ARM	BRAZO
5	191168	8	DADO	ECROU	MUTTER	NUT	TUERCA
6	373906	2	PATTINO	PATIN	GLEITBLOCK	SLIDING BLOCK	PATIN
7	191033	2	DADO	ECROU	MUTTER	NUT	TUERCA
8	208287	2	FERMO	ARRET	VERSTELLVORRICHTUNG	LOCK	TOPE
9	380229	2	PERNO	AXE	BOLZEN	PIN	PERNO
10	466552	2	SUPPORTO	SUPPORT	TRÄGER	SUPPORT	SOPORTE
11	417025	4	RONDELLA	RONDELLE	SCHEIBE	WASHER	ARANDELA
12	497134	8	VITE	VIS	SCHRAUBE	SCREW	TORNILLO
13	191045	2	DADO	ECROU	MUTTER	NUT	TUERCA
14	417005	2	RONDELLA	RONDELLE	SCHEIBE	WASHER	ARANDELA
15	349130	2	MOLLA	RESSORT	FEDER	SPRING	MUELLE
16	455023	2	SPINA	GOUPILLE	STIFT	PIN	PASADOR
17	497111	2	VITE	VIS	SCHRAUBE	SCREW	TORNILLO
18	208288	2	FERMO	ARRET	VERSTELLVORRICHTUNG	LOCK	TOPE
19	497966	4	VITE	VIS	SCHRAUBE	SCREW	TORNILLO
20	497383	4	VITE	VIS	SCHRAUBE	SCREW	TORNILLO
21	208292	4	FERMO	ARRET	VERSTELLVORRICHTUNG	LOCK	TOPE
22	417252	8	RONDELLA	RONDELLE	SCHEIBE	WASHER	ARANDELA
23	373907	2	PATTINO	PATIN	GLEITBLOCK	SLIDING BLOCK	PATIN
24	417004	4	RONDELLA	RONDELLE	SCHEIBE	WASHER	ARANDELA
25	136934	4	BOCCOLA	DOUILLE	BUCHSE	BUSHING	CASQUILLO
26	349142	4	MOLLA	RESSORT	FEDER	SPRING	MUELLE



COLONNA

- * Colonne
- * Säule
- * Column
- * Columna

TAV. GC.01.01

matr. G107.0005

21
23 P

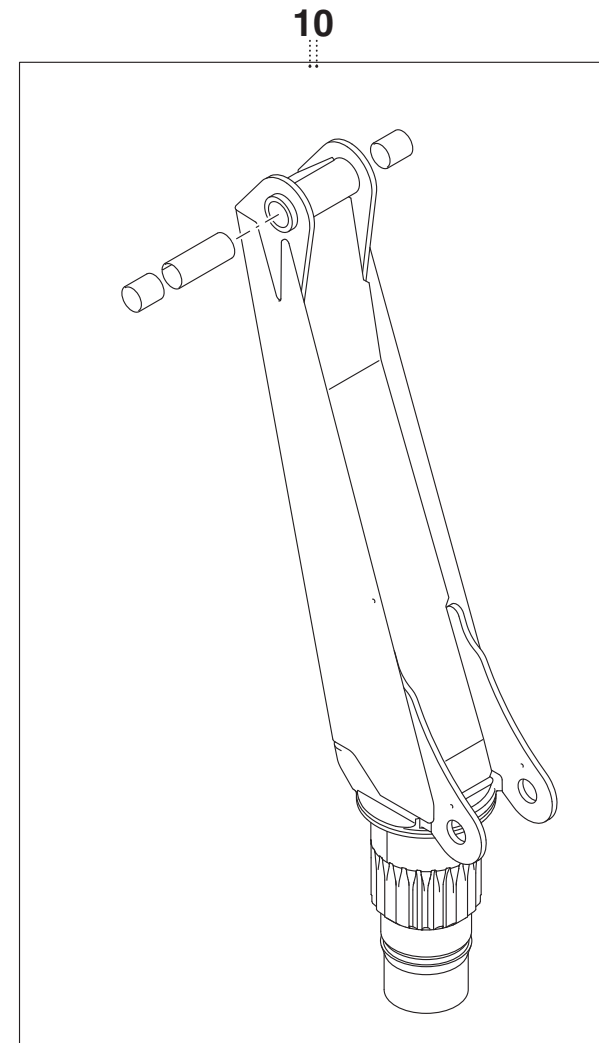
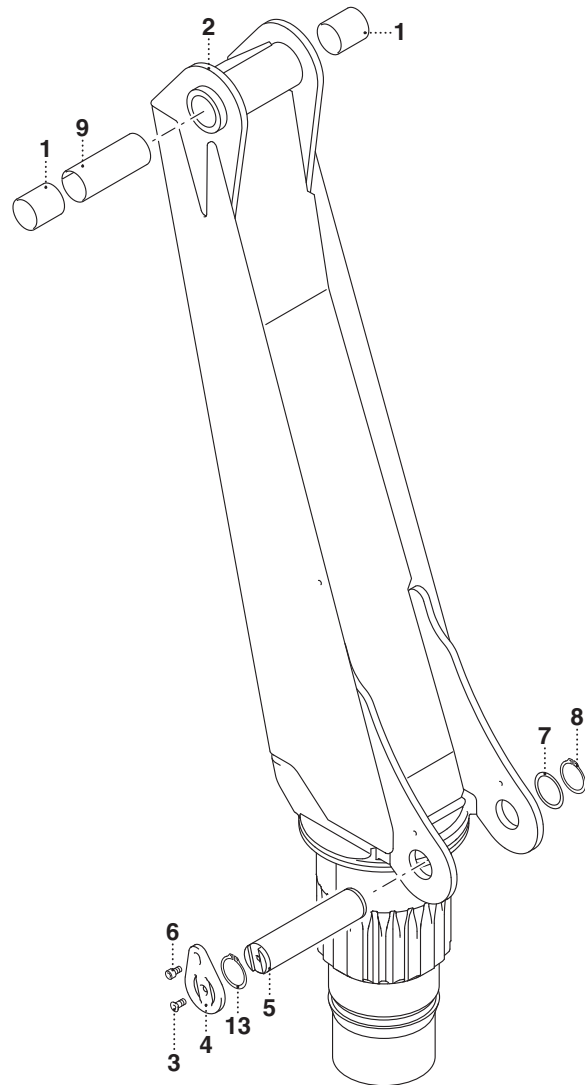



LUBRIFICAZIONE ROTAZIONE CON OLIO

- * Graissage rotation avec huile
- * Schwenkschmierung mit Öl
- * Rotation lubrication with oil
- * Lubricación rotación con aceite

TAV. GC.02.01

matr. G107.0005

21
23 P

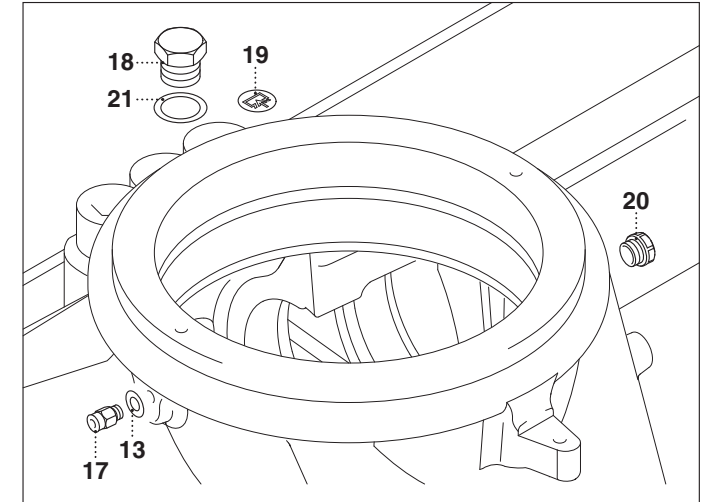
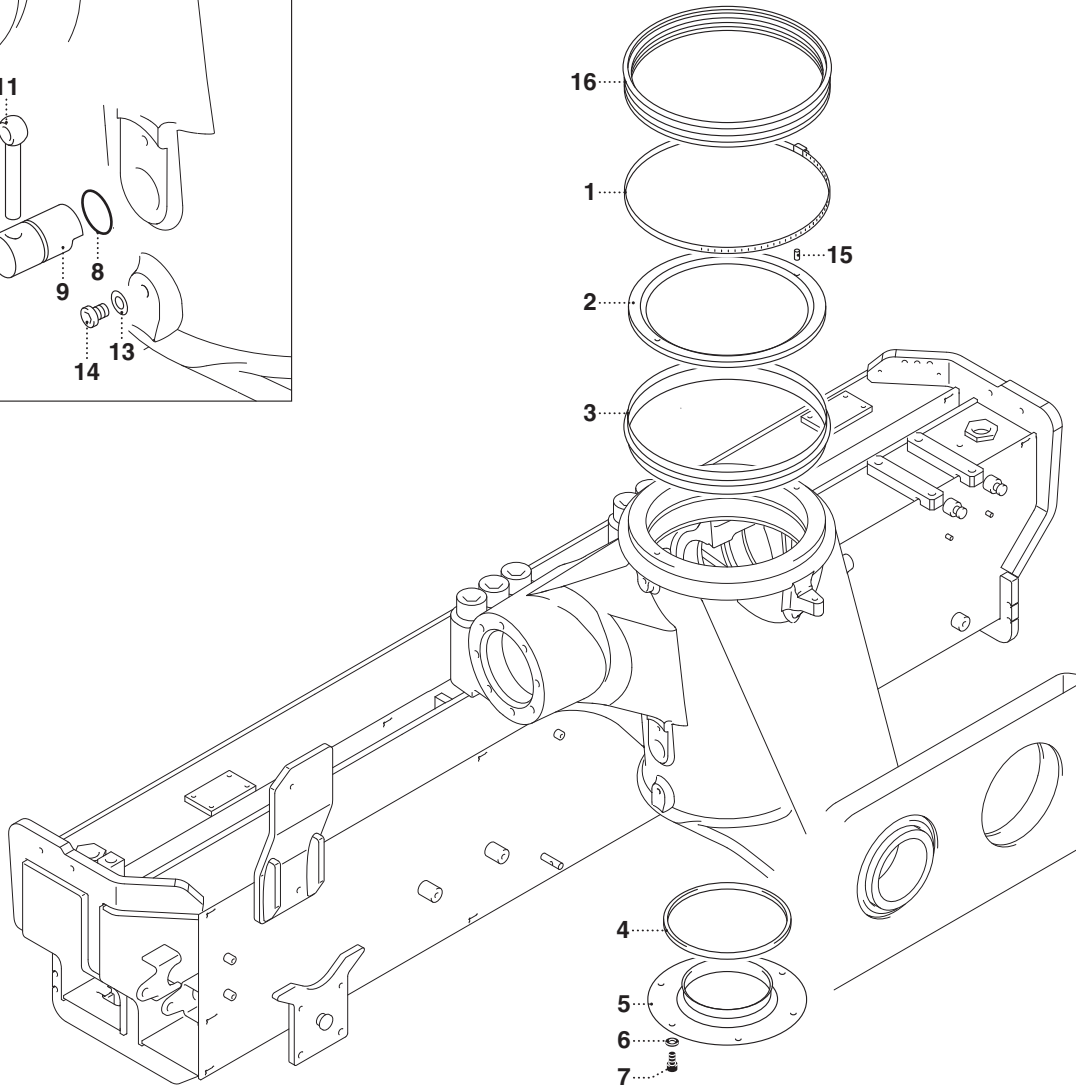
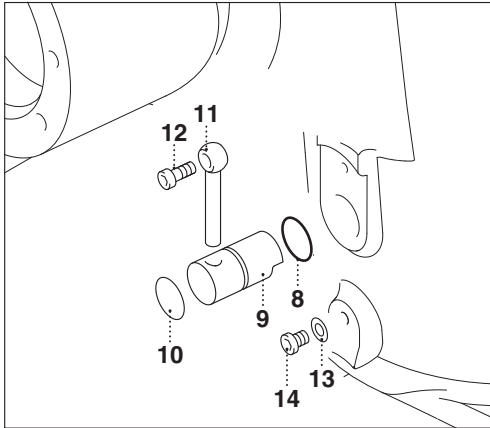

PM 21 - PM 23 P

matr. G107.0005

TAV. GC.02.01

POS.	N° CODICE	Q.	DESCRIZIONE	DESIGNATION	BENENNUNG	DESCRIPTION	DENOMINACIONES
1	207083	1	FASCETTA	COLLIER	HALTEBAND	CLAMP	ABRAZADERA
2	112230	1	ANELLO	BAGUE	RING	RING	ANILLO
3	112232	1	GUARNIZIONE	JOINT	DICHTUNG	SEAL	GUARNICION
4	273934	1	GUARNIZIONE	JOINT	DICHTUNG	SEAL	GUARNICION
5	403268	1	PROTEZIONE	PROTECTION	SCHUTZ	GUARD	PROTECCION
6	417004	6	RONDELLA	RONDELLE	SCHEIBE	WASHER	ARANDELA
7	497237	6	VITE	VIS	SCHRAUBE	SCREW	TORNILLO
8	273093	2	GUARNIZIONE	JOINT	DICHTUNG	SEAL	GUARNICION
9	380467	2	PERNO	AXE	BOLZEN	PIN	PERNO
10	171335	2	TARGHETTA	AUTOCOLLANT	SCHILD	DECAL	ETIQUETA
11	498150	2	VITE	VIS	SCHRAUBE	SCREW	TORNILLO
12	497238	2	VITE	VIS	SCHRAUBE	SCREW	TORNILLO
13	417076	4	RONDELLA	RONDELLE	SCHEIBE	WASHER	ARANDELA
14	471285	2	TAPPO	BOUCHON	VERSCHLUSSDECKEL	PLUG	TAPON
15	455016	2	SPINA	GOUPILLE	STIFT	PIN	PASADOR
16	271290	1	GUARNIZIONE	JOINT	DICHTUNG	SEAL	GUARNICION
17	409415	2	RACCORDO	RACCORD	ANSCHLUSS	FITTING	RACOR
18	471029	1	TAPPO	BOUCHON	VERSCHLUSSDECKEL	PLUG	TAPON
19	171336	1	TARGHETTA	AUTOCOLLANT	SCHILD	DECAL	ETIQUETA
20	471349	1	TAPPO	BOUCHON	VERSCHLUSSDECKEL	PLUG	TAPON
21	417093	1	RONDELLA	RONDELLE	SCHEIBE	WASHER	ARANDELA



LUBRIFICAZIONE ROTAZIONE CON GRASSO

- * Graissage rotation avec graisse
- * Schwenkschmierung mit Fett
- * Rotation lubrication with grease
- * Lubricación rotación con grasa

TAV. GC.02.02

matr. G107.0005

21
23 P

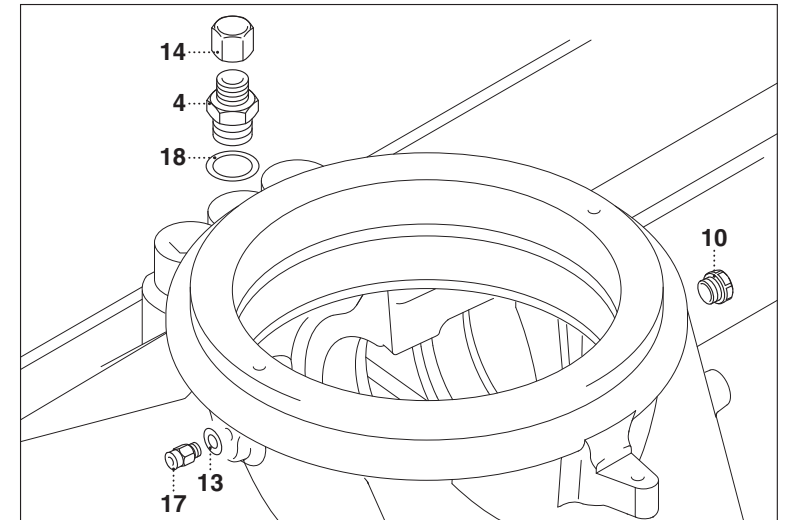
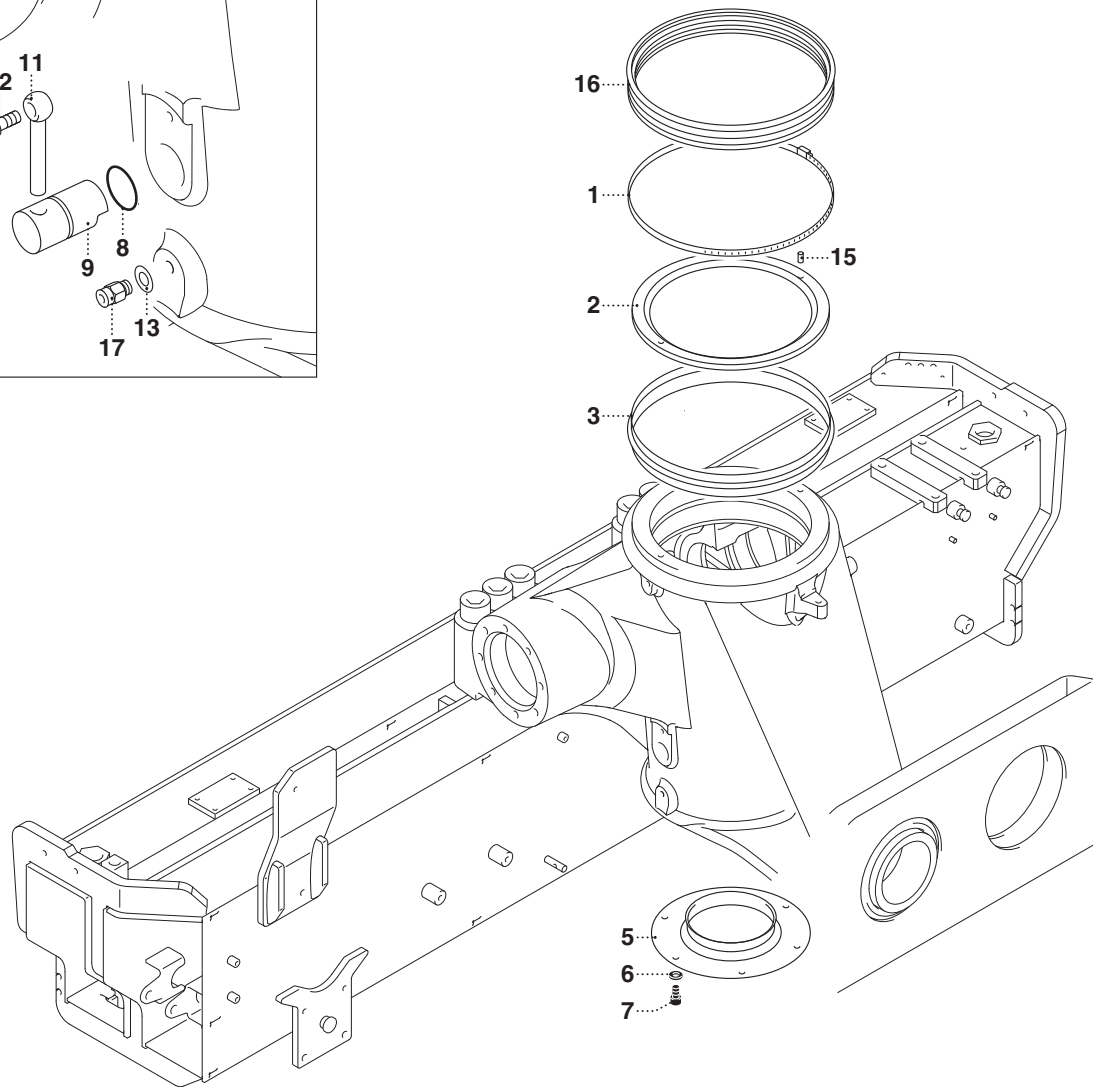
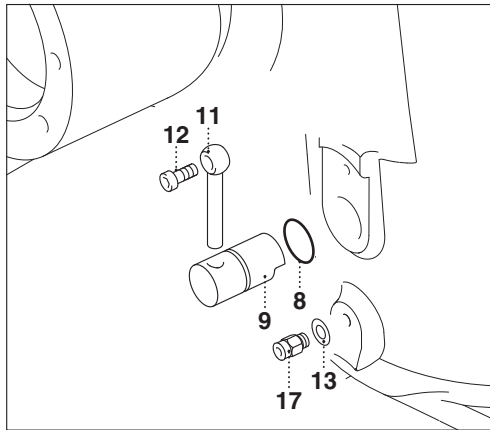

PM 21 - PM 23 P

matr. G107.0005

TAV. GC.02.02

POS.	N° CODICE	Q.	DESCRIZIONE	DESIGNATION	BENENNUNG	DESCRIPTION	DENOMINACIONES
1	207083	1	FASCETTA	COLLIER	HALTEBAND	CLAMP	ABRAZADERA
2	112230	1	ANELLO	BAGUE	RING	RING	ANILLO
3	112232	1	GUARNIZIONE	JOINT	DICHTUNG	SEAL	GUARNICION
4	409453	1	RACCORDO	RACCORD	ANSCHLUSS	FITTING	RACOR
5	403268	1	PROTEZIONE	PROTECTION	SCHUTZ	GUARD	PROTECCION
6	417004	6	RONDELLA	RONDELLE	SCHEIBE	WASHER	ARANDELA
7	497237	6	VITE	VIS	SCHRAUBE	SCREW	TORNILLO
8	273093	2	GUARNIZIONE	JOINT	DICHTUNG	SEAL	GUARNICION
9	380467	2	PERNO	AXE	BOLZEN	PIN	PERNO
10	471024	1	TAPPO	BOUCHON	VERSCHLUSSDECKEL	PLUG	TAPON
11	498150	2	VITE	VIS	SCHRAUBE	SCREW	TORNILLO
12	497238	2	VITE	VIS	SCHRAUBE	SCREW	TORNILLO
13	417076	4	RONDELLA	RONDELLE	SCHEIBE	WASHER	ARANDELA
14	395838	1	RACCORDO	RACCORD	ANSCHLUSS	FITTING	RACOR
15	455016	2	SPINA	GOUPILLE	STIFT	PIN	PASADOR
16	271290	1	GUARNIZIONE	JOINT	DICHTUNG	SEAL	GUARNICION
17	409415	4	RACCORDO	RACCORD	ANSCHLUSS	FITTING	RACOR
18	417093	1	RONDELLA	RONDELLE	SCHEIBE	WASHER	ARANDELA



BRACCIO PRINCIPALE

* Bras principal
* Hauptarm
* Main arm
* Brazo principal

TAV. GD.01.01

matr. G107.0005

21
23 P

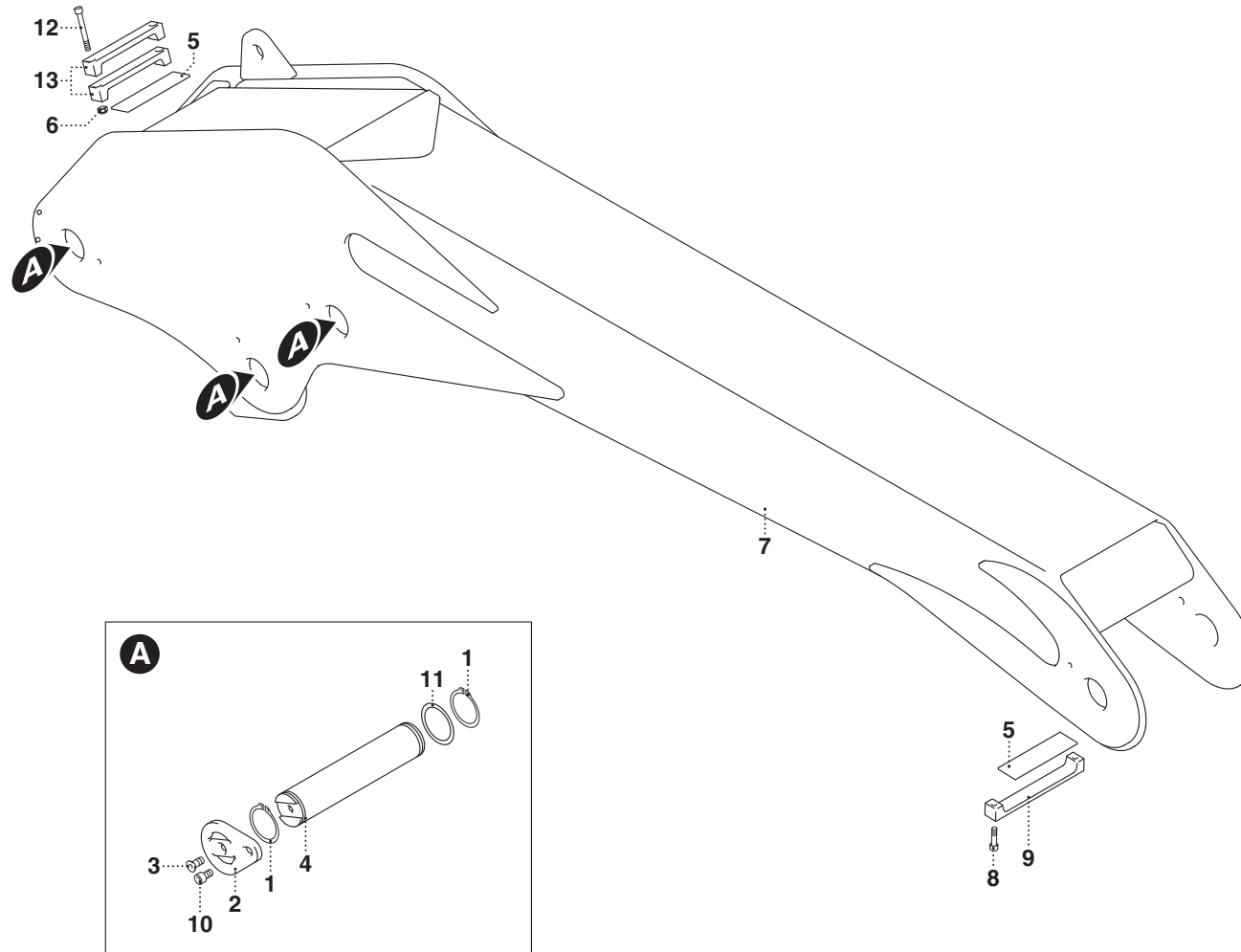

PM 21 - PM 23 P

matr. G107.0005

TAV. GD.01.01

POS.	N° CODICE	Q.	DESCRIZIONE	DESIGNATION	BENENNUNG	DESCRIPTION	DENOMINACIONES
1	109204	6	ANELLO ELASTICO	JOINT D'ARRET	SPRENGRING	SPRING RING	ANILLO ELASTICO
2	208278	3	FERMO	ARRET	VERSTELLVORRICHTUNG	LOCK	TOPE
3	497949	3	VITE	VIS	SCHRAUBE	SCREW	TORNILLO
4	380457	3	PERNO	AXE	BOLZEN	PIN	PERNO
5	403269	2	PROTEZIONE	PROTECTION	SCHUTZ	GUARD	PROTECCION
6	191168	2	DADO	ECROU	MUTTER	NUT	TUERCA
7	345102	1	BRACCIO PRINCIPALE	BRAS PRINCIPAL	HAUPTARM	MAIN ARM	BRAZO PRINCIPAL
8	497132	2	VITE	VIS	SCHRAUBE	SCREW	TORNILLO
9	467572	1	FERMO	ARRET	VERSTELLVORRICHTUNG	LOCK	TOPE
10	498223	3	VITE	VIS	SCHRAUBE	SCREW	TORNILLO
11	112225	3	ANELLO	BAGUE	RING	RING	ANILLO
12	497139	2	VITE	VIS	SCHRAUBE	SCREW	TORNILLO
13	467571	2	FERMO	ARRET	VERSTELLVORRICHTUNG	LOCK	TOPE



MARTINETTO STABILIZZATORI FISSI - 340434

* Vérin stabilisateurs fixes
* Feststützzylindern
* Fixed outriggers cylinders
* Cilindro estabilizadores fijos

TAV. GE.01.01

matr. G107.0005

21
23 P

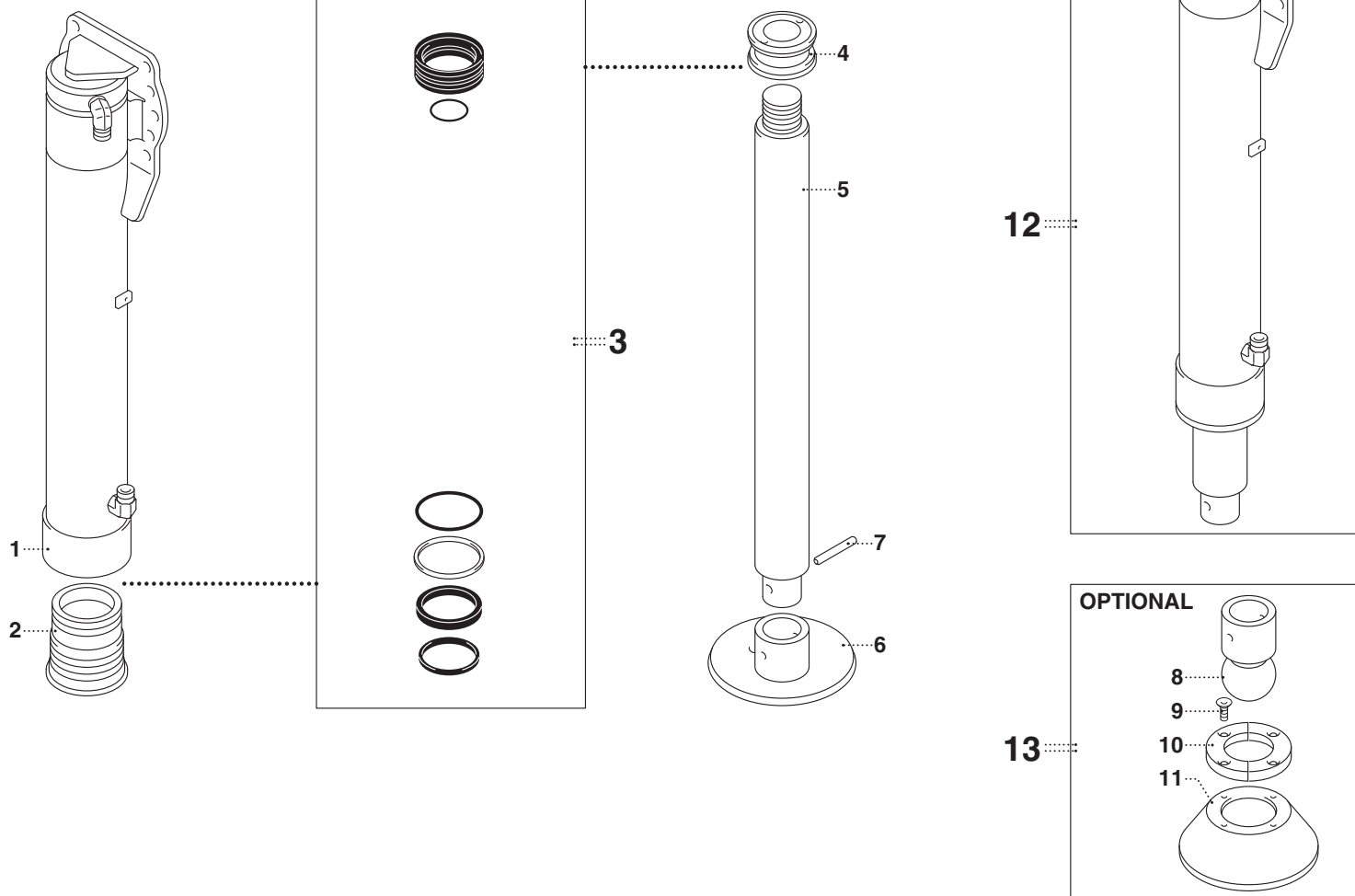

PM 21 - PM 23 P

matr. G107.0005

TAV. GE.01.01

POS.	N° CODICE	Q.	DESCRIZIONE	DESIGNATION	BENENNUNG	DESCRIPTION	DENOMINACIONES
1	161848	1	CILINDRO	CYLINDRE	ZYLINDER	CYLINDER	CILINDRO
2	479907	1	TESTATA	TETE	KOPF	HEAD	CABEZA
3	280541	1	KIT GUARNIZIONI	KIT JOINTS	DICHTUNGSSATZ	SEALS KIT	KIT JUNTAS
4	382459	1	PISTONE	PISTON	KOLBEN	PISTON	PISTON
5	121821	1	ASTA	TIGE	STANGE	ROD	VARILLA
6	467497	1	PROLUNGA	RALLONGE	VERLÄNGERUNG	EXTENSION	PROLONGA
7	455225	1	SPINA	GOUPILLE	STIFT	PIN	PASADOR
8	447018	1	SFERA	BILLE	KUGEL	BALL	ESFERA
9	497499	4	VITE	VIS	SCHRAUBE	SCREW	TORNILLO
10	219164	2	FLANGIA	BRIDE	FLANSCH	FLANGE	BRIDA
11	467326	1	APPOGGIO	APPUI	UNTERLAGE	BEARING	PIE
12	292201	1	KIT MARTINETTO	KIT VERIN	ZYLINDERSATZ	CYLINDER KIT	KIT CILINDRO
13	280772	1	KIT APPOGGIO	KIT APPUI	UNTERLAGESATZ	BEARING KIT	KIT PIE



MARTINETTO STABILIZZATORI ROTANTI - 340428

* Vérin stabilisateurs tournants
* Drehstützzylindern
* Rotating outriggers cylinders
* Cilindro estabilizadores rotatorios

TAV. GE.01.02

matr. G107.0005

21
23 P

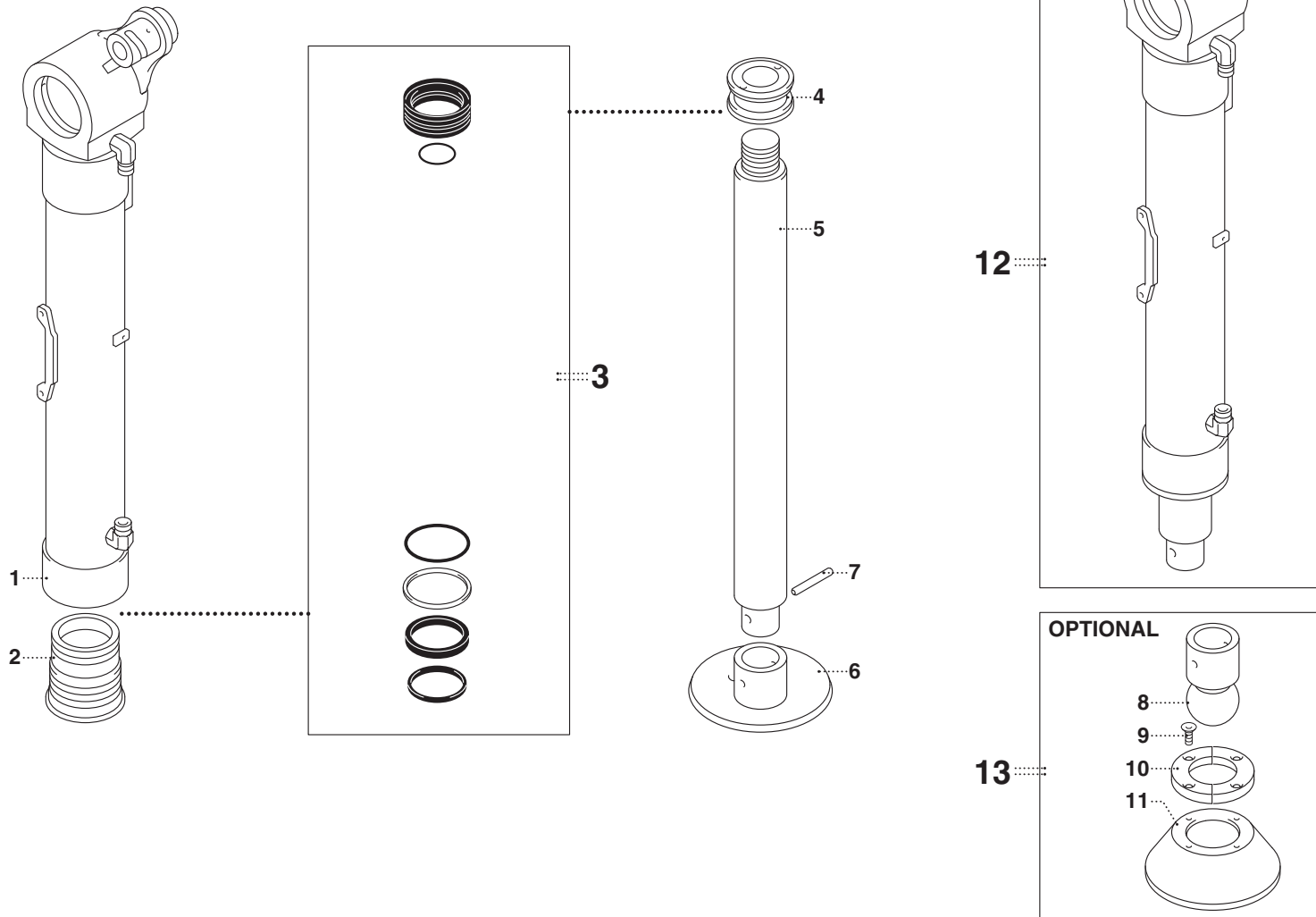

PM 21 - PM 23 P

matr. G107.0005

TAV. GE.01.02

POS.	N° CODICE	Q.	DESCRIZIONE	DESIGNATION	BENENNUNG	DESCRIPTION	DENOMINACIONES
1	161847	1	CILINDRO	CYLINDRE	ZYLINDER	CYLINDER	CILINDRO
2	479907	1	TESTATA	TETE	KOPF	HEAD	CABEZA
3	280541	1	KIT GUARNIZIONI	KIT JOINTS	DICHTUNGSSATZ	SEALS KIT	KIT JUNTAS
4	382459	1	PISTONE	PISTON	KOLBEN	PISTON	PISTON
5	121821	1	ASTA	TIGE	STANGE	ROD	VARILLA
6	467497	1	PROLUNGA	RALLONGE	VERLÄNGERUNG	EXTENSION	PROLONGA
7	455225	1	SPINA	GOUPILLE	STIFT	PIN	PASADOR
8	447018	1	SFERA	BILLE	KUGEL	BALL	ESFERA
9	497499	4	VITE	VIS	SCHRAUBE	SCREW	TORNILLO
10	219164	2	FLANGIA	BRIDE	FLANSCH	FLANGE	BRIDA
11	467326	1	APPOGGIO	APPUI	UNTERLAGE	BEARING	PIE
12	292202	1	KIT MARTINETTO	KIT VERIN	ZYLINDERSATZ	CYLINDER KIT	KIT CILINDRO
13	280772	1	KIT APPOGGIO	KIT APPUI	UNTERLAGESATZ	BEARING KIT	KIT PIE



MARTINETTO SFILO BRACCI STAB. STANDARD - 340420

- * Vérin extension bras stabilisateurs standard
- * Stützarmausziehenzylinder - standard
- * Standard outrigger arms extension cylinder
- * Cilindro extensión brazos estabilizadores estándar

TAV. GE.02.01

matr. G107.0005

21
23 P

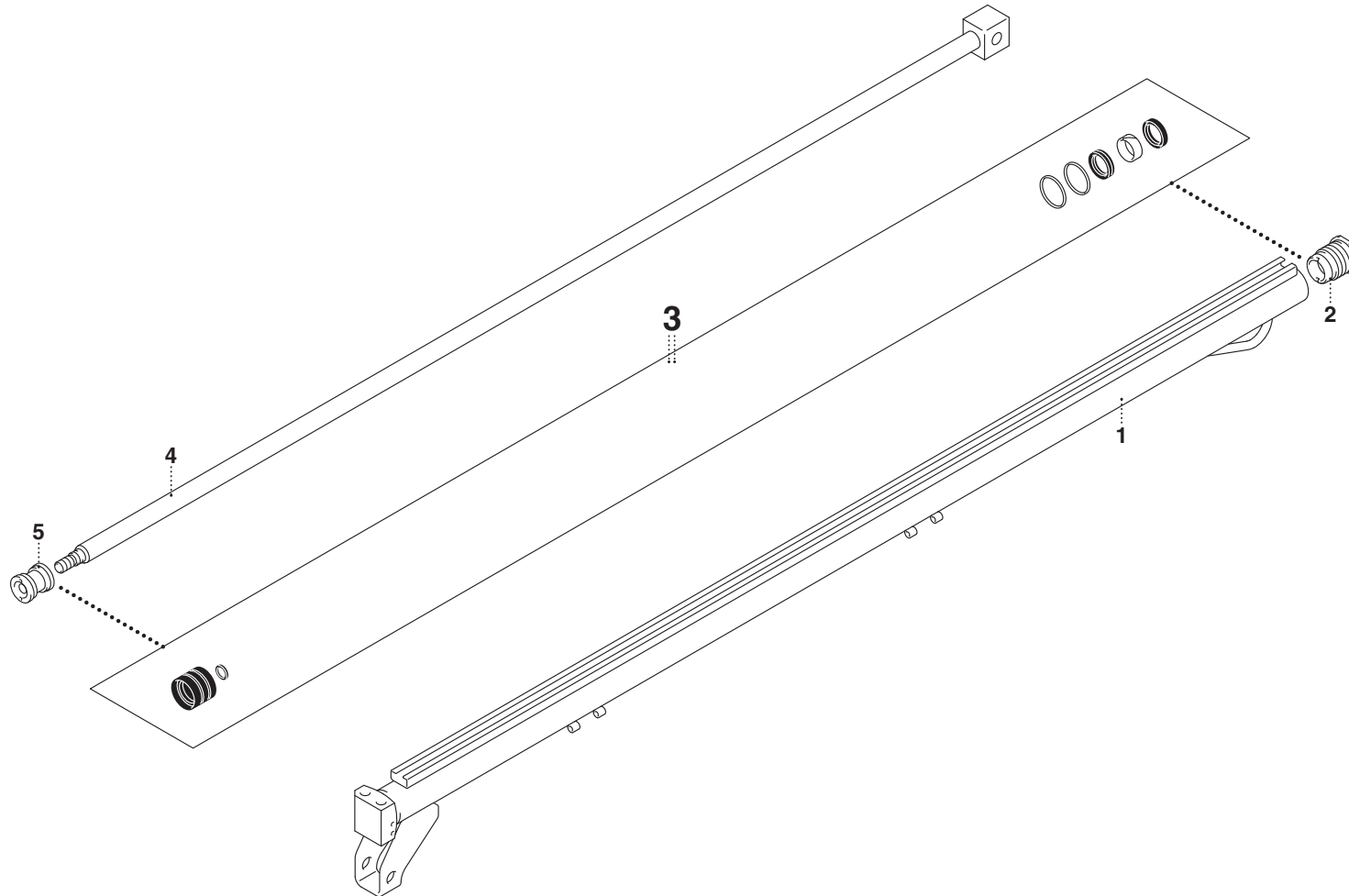

PM 21 - PM 23 P

matr. G107.0005

TAV. GE.02.01

POS.	N° CODICE	Q.	DESCRIZIONE	DESIGNATION	BENENNUNG	DESCRIPTION	DENOMINACIONES
1	161844	1	CILINDRO	CYLINDRE	ZYLINDER	CYLINDER	CILINDRO
2	479435	1	TESTATA	TETE	KOPF	HEAD	CABEZA
3	230009	1	KIT GUARNIZIONI	KIT JOINTS	DICHTUNGSSATZ	SEALS KIT	KIT JUNTAS
4	121818	1	ASTA	TIGE	STANGE	ROD	VARILLA
5	382478	1	PISTONE	PISTON	KOLBEN	PISTON	PISTON

PM 21 - PM 23 P

matr. G107.0005

TAV. GE.02.02

POS.	N° CODICE	Q.	DESCRIZIONE	DESIGNATION	BENENNUNG	DESCRIPTION	DENOMINACIONES
1	161841	1	CILINDRO	CYLINDRE	ZYLINDER	CYLINDER	CILINDRO
2	479435	1	TESTATA	TETE	KOPF	HEAD	CABEZA
3	230009	1	KIT GUARNIZIONI	KIT JOINTS	DICHTUNGSSATZ	SEALS KIT	KIT JUNTAS
4	121817	1	ASTA	TIGE	STANGE	ROD	VARILLA
5	382478	1	PISTONE	PISTON	KOLBEN	PISTON	PISTON



MARTINETTO PRINCIPALE - 340439

- * Vérin principal
- * Hauptzylinder
- * Main cylinder
- * Cilindro principal

TAV. GF.01.01

matr. G107.0005

21
23 P

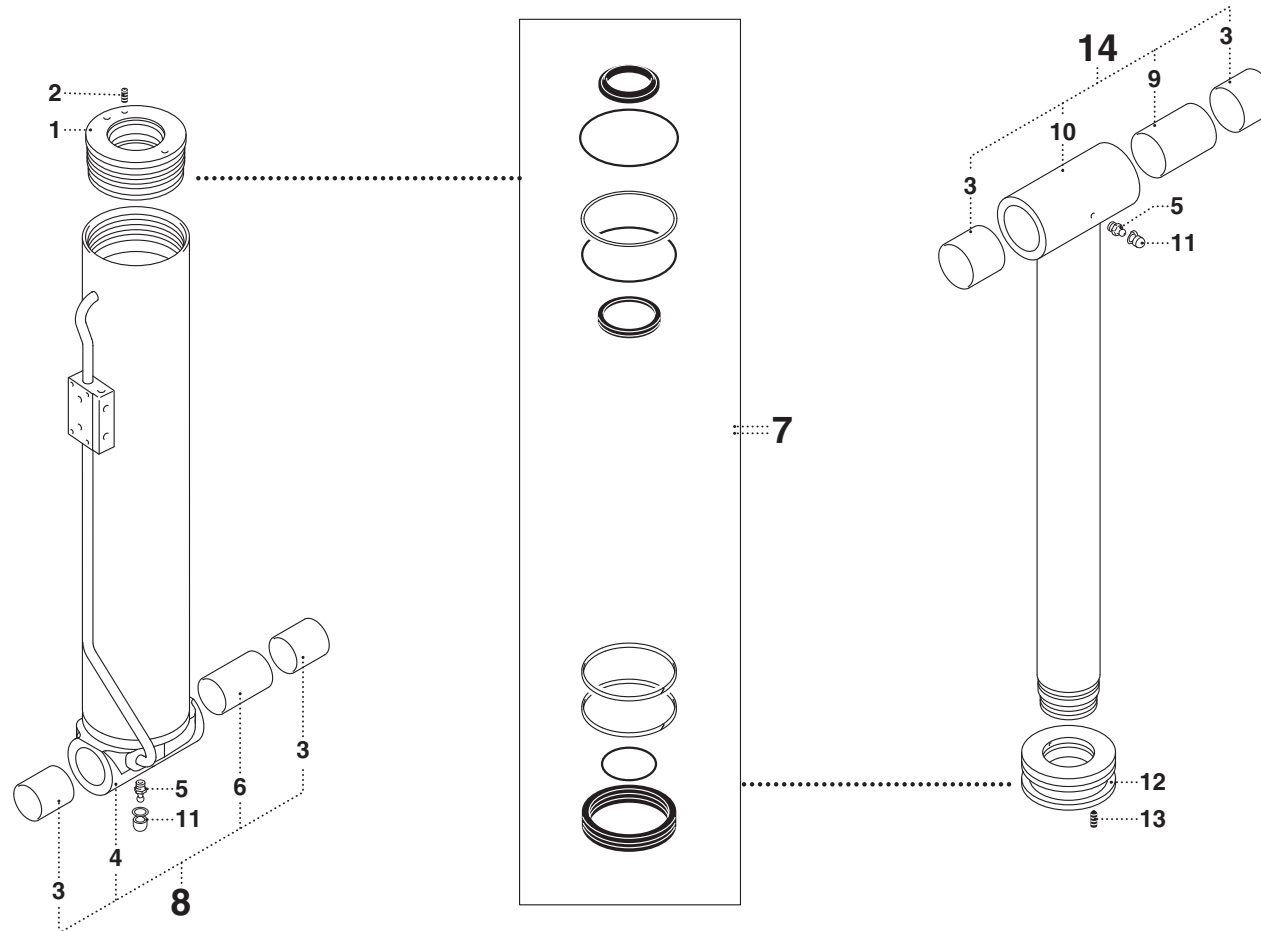

PM 21 - PM 23 P

matr. G107.0005

TAV. GF.01.01

POS.	N° CODICE	Q.	DESCRIZIONE	DESIGNATION	BENENNUNG	DESCRIPTION	DENOMINACIONES
1	479916	1	TESTATA	TETE	KOPF	HEAD	CABEZA
2	497283	1	VITE	VIS	SCHRAUBE	SCREW	TORNILLO
3	137135	4	BOCCOLA	DOUILLE	BUCHSE	BUSHING	CASQUILLO
4	161862	1	CILINDRO	CYLINDRE	ZYLINDER	CYLINDER	CILINDRO
5	281010	2	INGRASSATORE	GRAISSEUR	SCHMIERER	GREASE FITTING	ENGRASADOR
6	139004	1	DISTANZIALE	ENTRETOISE	DISTANZSTÜCK	SPACER	DISTANCIADOR
7	230003	1	KIT GUARNIZIONI	KIT JOINTS	DICHTUNGSSATZ	SEALS KIT	KIT JUNTAS
8	280925	1	KIT CILINDRO	KIT CYLINDRE	ZYLINDERSATZ	CYLINDER KIT	KIT CILINDRO
9	139005	1	DISTANZIALE	ENTRETOISE	DISTANZSTÜCK	SPACER	DISTANCIADOR
10	121848	1	ASTA	TIGE	STANGE	ROD	VARILLA
11	471215	2	TAPPO	BOUCHON	VERSCHLUSSDECKEL	PLUG	TAPON
12	382476	1	PISTONE	PISTON	KOLBEN	PISTON	PISTON
13	497465	2	VITE	VIS	SCHRAUBE	SCREW	TORNILLO
14	280926	1	KIT ASTA	KIT TIGE	STANGESATZ	ROD KIT	KIT VARILLA



MARTINETTO SECONDARIO - 340440

- * *Vérin secondaire*
- * *Nebenzyylinder*
- * *Secondary cylinder*
- * *Cilindro secundario*

TAV. GF.02.01

matr. G107.0005

21
23 P

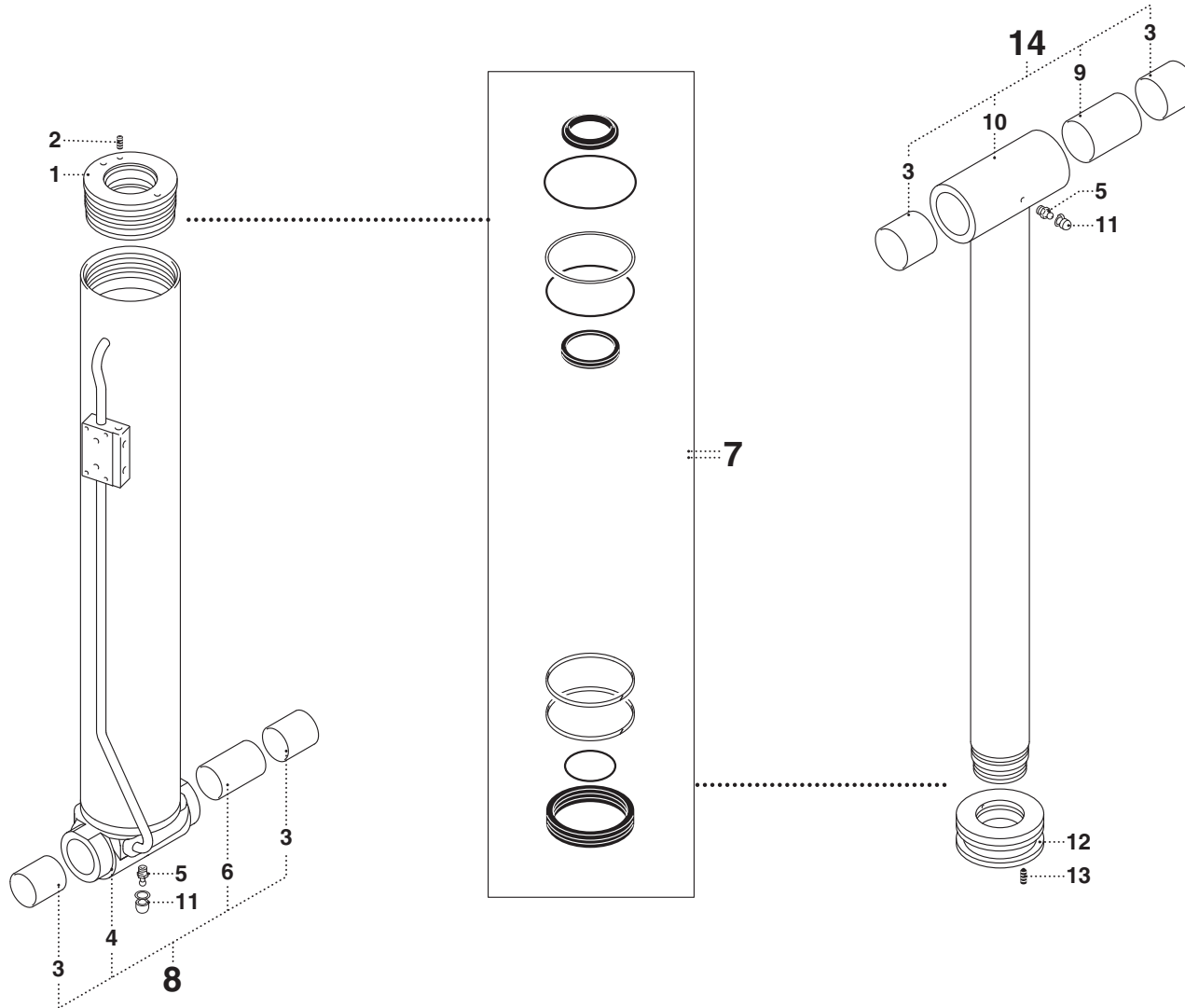

PM 21 - PM 23 P

matr. G107.0005

TAV. GF.02.01

POS.	N° CODICE	Q.	DESCRIZIONE	DESIGNATION	BENENNUNG	DESCRIPTION	DENOMINACIONES
1	479916	1	TESTATA	TETE	KOPF	HEAD	CABEZA
2	497283	1	VITE	VIS	SCHRAUBE	SCREW	TORNILLO
3	137135	4	BOCCOLA	DOUILLE	BUCHSE	BUSHING	CASQUILLO
4	161863	1	CILINDRO	CYLINDRE	ZYLINDER	CYLINDER	CILINDRO
5	281010	2	INGRASSATORE	GRAISSEUR	SCHMIERER	GREASE FITTING	ENGRASADOR
6	139005	1	DISTANZIALE	ENTRETOISE	DISTANZSTÜCK	SPACER	DISTANCIADOR
7	230003	1	KIT GUARNIZIONI	KIT JOINTS	DICHTUNGSSATZ	SEALS KIT	KIT JUNTAS
8	280927	1	KIT CILINDRO	KIT CYLINDRE	ZYLINDERSATZ	CYLINDER KIT	KIT CILINDRO
9	139010	1	DISTANZIALE	ENTRETOISE	DISTANZSTÜCK	SPACER	DISTANCIADOR
10	121849	1	ASTA	TIGE	STANGE	ROD	VARILLA
11	471215	2	TAPPO	BOUCHON	VERSCHLUSSDECKEL	PLUG	TAPON
12	382476	1	PISTONE	PISTON	KOLBEN	PISTON	PISTON
13	497465	2	VITE	VIS	SCHRAUBE	SCREW	TORNILLO
14	280928	1	KIT ASTA	KIT TIGE	STANGESATZ	ROD KIT	KIT VARILLA



FODERO (LC)

- * Fourreau (LC)
- * Futter (LC)
- * Cover (LC)
- * Camisa (LC)

TAV. GG.01.01

matr. G107.0005

21
23 P

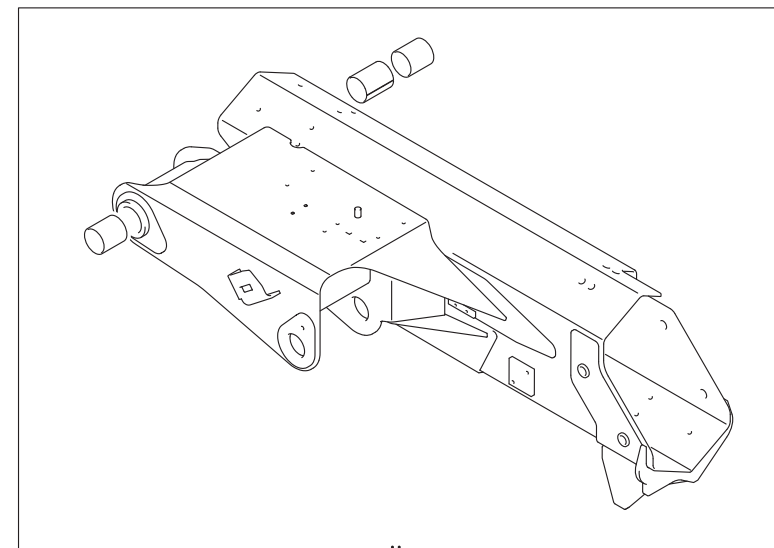
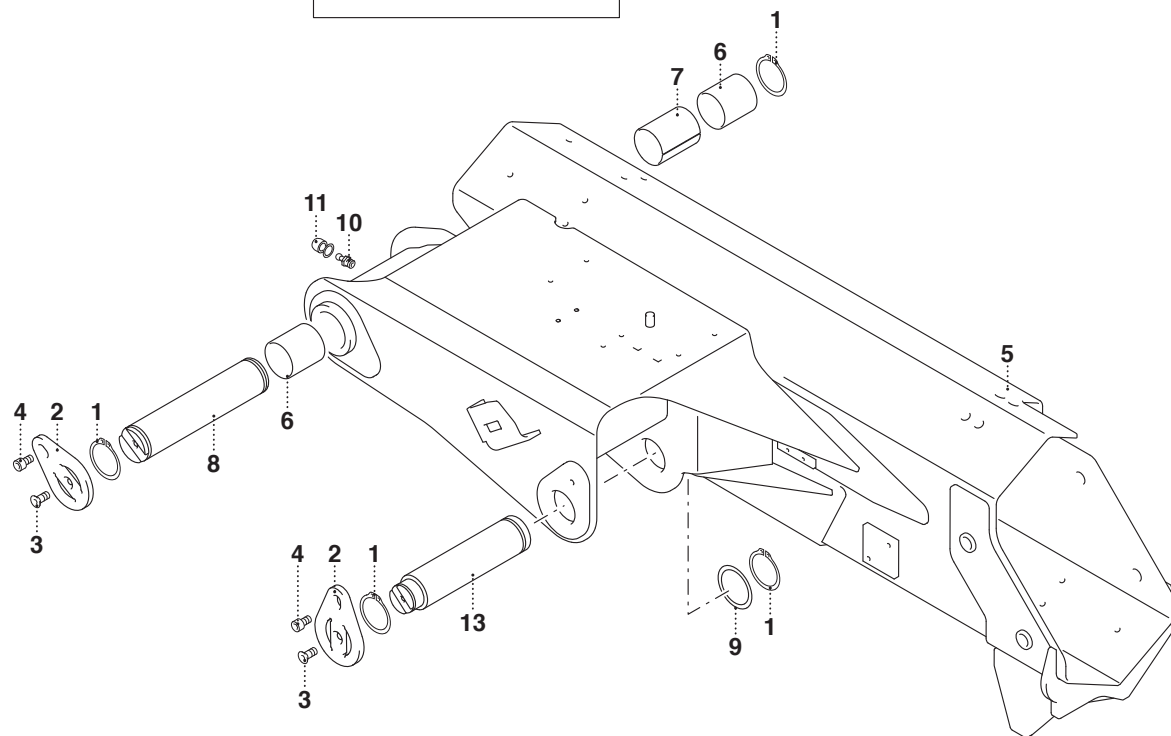
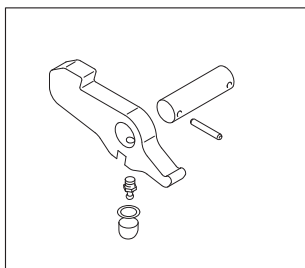

12

PM 21 LC - PM 23 P LC

matr. G107.0005

TAV. GG.01.01

POS.	N° CODICE	Q.	DESCRIZIONE	DESIGNATION	BENENNUNG	DESCRIPTION	DENOMINACIONES
1	109204	4	ANELLO ELASTICO	JOINT D'ARRET	SPRENGRING	SPRING RING	ANILLO ELASTICO
2	208278	1	FERMO	ARRET	VERSTELLVORRICHTUNG	LOCK	TOPE
3	497949	2	VITE	VIS	SCHRAUBE	SCREW	TORNILLO
4	498223	2	VITE	VIS	SCHRAUBE	SCREW	TORNILLO
5	142599	1	FODERO	FOURREAU	FUTTER	COVER	CAMISA
6	137135	2	BOCCOLA	DOUILLE	BUCHSE	BUSHING	CASQUILLO
7	136951	1	BOCCOLA	DOUILLE	BUCHSE	BUSHING	CASQUILLO
8	380457	1	PERNO	AXE	BOLZEN	PIN	PERNO
9	112225	1	ANELLO	BAGUE	RING	RING	ANILLO
10	281010	1	INGRASSATORE	GRAISSEUR	SCHMIERER	GREASE FITTING	ENGRASADOR
11	471215	1	TAPPO	BOUCHON	VERSCHLUSSDECKEL	PLUG	TAPON
12	278095	1	KIT FODERO	KIT FOURREAU	FUTTERSATZ	COVER KIT	KIT CAMISA
13	380458	1	PERNO	AXE	BOLZEN	PIN	PERNO



FODERO (LC)

- * Fourreau (LC)
- * Futter (LC)
- * Cover (LC)
- * Camisa (LC)

TAV. GG.01.01A

matr. G107.0069

21
23 P

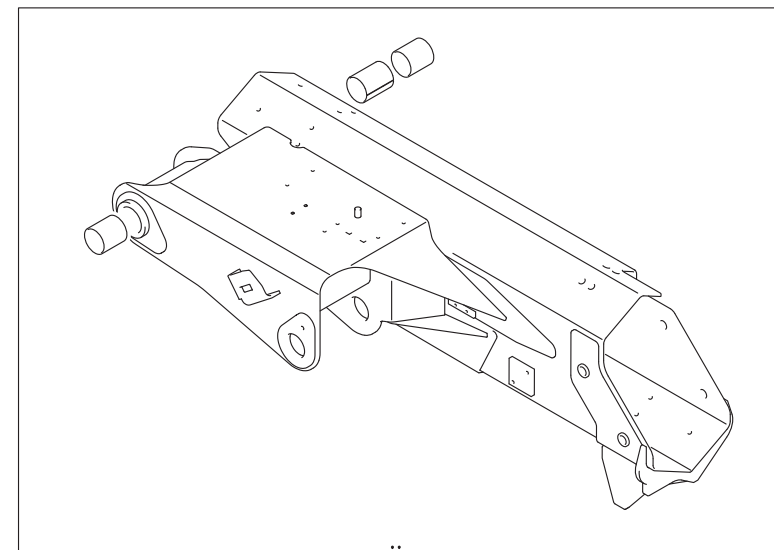
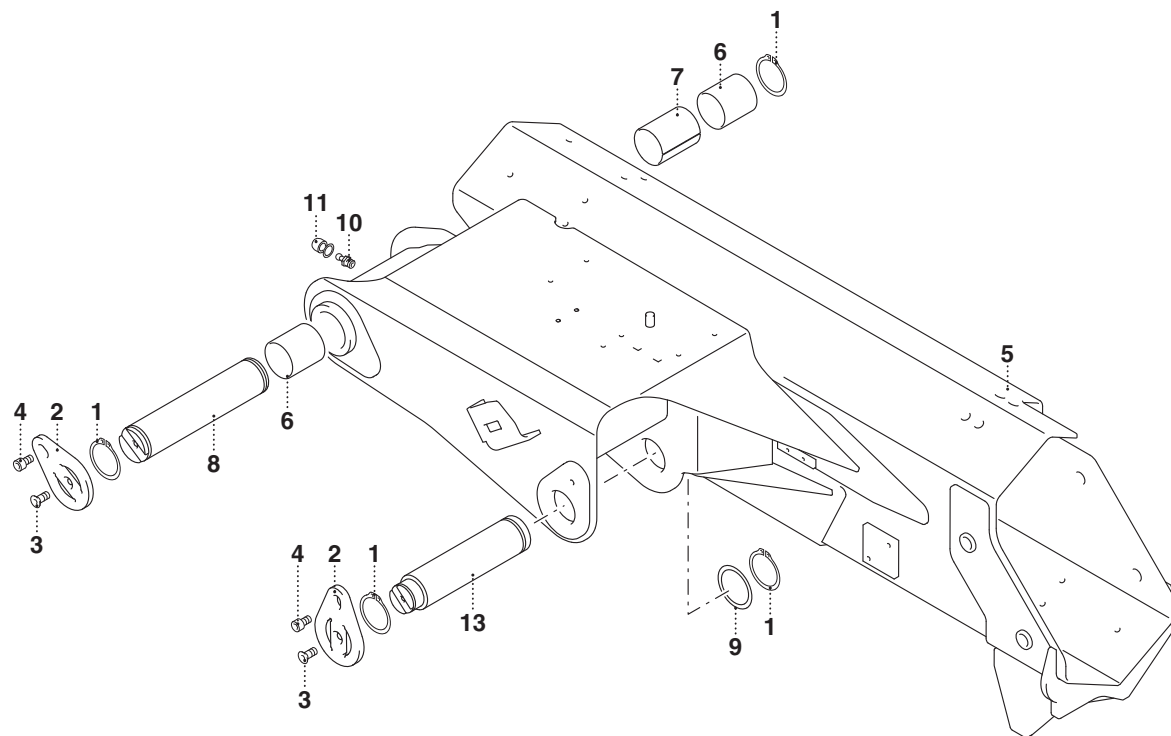

12

PM 21 LC - PM 23 P LC

matr. G107.0069

TAV. GG.01.01A

POS.	N° CODICE	Q.	DESCRIZIONE	DESIGNATION	BENENNUNG	DESCRIPTION	DENOMINACIONES
1	109204	4	ANELLO ELASTICO	JOINT D'ARRET	SPRENGRING	SPRING RING	ANILLO ELASTICO
2	208278	1	FERMO	ARRET	VERSTELLVORRICHTUNG	LOCK	TOPE
3	497949	2	VITE	VIS	SCHRAUBE	SCREW	TORNILLO
4	498223	2	VITE	VIS	SCHRAUBE	SCREW	TORNILLO
5	142699	1	FODERO	FOURREAU	FUTTER	COVER	CAMISA
6	137135	2	BOCCOLA	DOUILLE	BUCHSE	BUSHING	CASQUILLO
7	136951	1	BOCCOLA	DOUILLE	BUCHSE	BUSHING	CASQUILLO
8	380457	1	PERNO	AXE	BOLZEN	PIN	PERNO
9	112225	1	ANELLO	BAGUE	RING	RING	ANILLO
10	281010	1	INGRASSATORE	GRAISSEUR	SCHMIERER	GREASE FITTING	ENGRASADOR
11	471215	1	TAPPO	BOUCHON	VERSCHLUSSDECKEL	PLUG	TAPON
12	278242	1	KIT FODERO	KIT FOURREAU	FUTTERSATZ	COVER KIT	KIT CAMISA
13	380458	1	PERNO	AXE	BOLZEN	PIN	PERNO



BRACCIO SECONDARIO

* Bras secondaire
* Nebenarm
* Secondary arm
* Brazo secundario

TAV. GG.02.01

matr. G107.0005

21
23 P

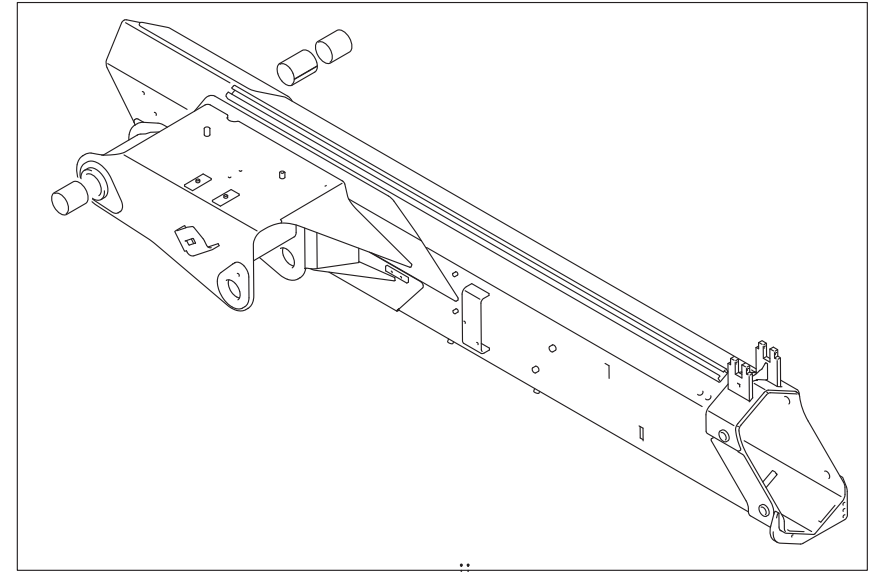
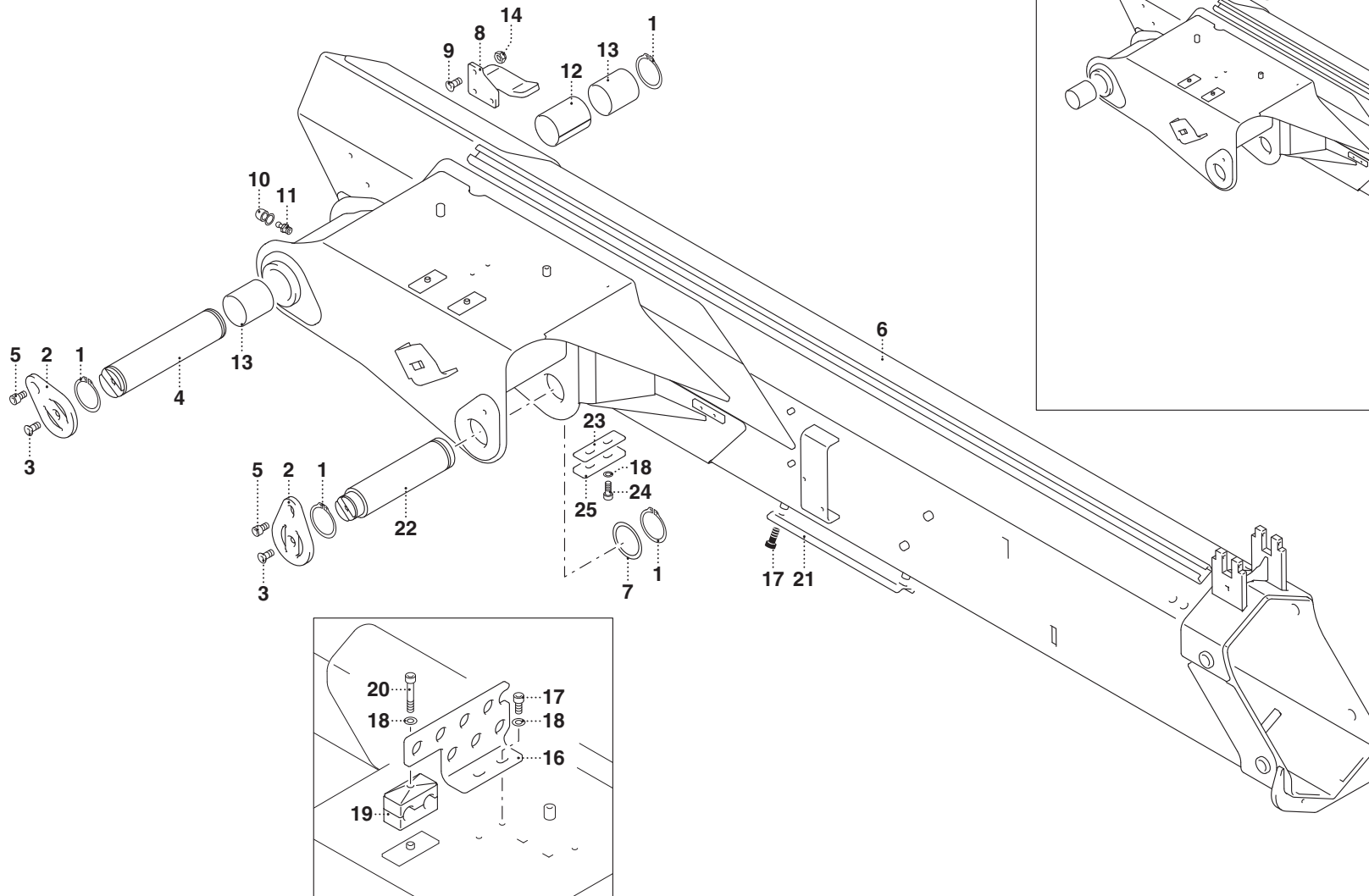

PM 21 - PM 23 P

matr. G107.0005

TAV. GG.02.01

POS.	N° CODICE	Q.	DESCRIZIONE	DESIGNATION	BENENNUNG	DESCRIPTION	DENOMINACIONES
1	109204	4	ANELLO ELASTICO	JOINT D'ARRET	SPRENGRING	SPRING RING	ANILLO ELASTICO
2	208278	2	FERMO	ARRET	VERSTELLVORRICHTUNG	LOCK	TOPE
3	497949	2	VITE	VIS	SCHRAUBE	SCREW	TORNILLO
4	380457	1	PERNO	AXE	BOLZEN	PIN	PERNO
5	498223	2	VITE	VIS	SCHRAUBE	SCREW	TORNILLO
6	142512	1	BRACCIO	BRAS	ARM	ARM	BRAZO
7	112225	1	ANELLO	BAGUE	RING	RING	ANILLO
8	467522	1	SUPPORTO	SUPPORT	TRÄGER	SUPPORT	SOPORTE
9	497449	3	VITE	VIS	SCHRAUBE	SCREW	TORNILLO
10	471215	2	TAPPO	BOUCHON	VERSCHLUSSDECKEL	PLUG	TAPON
11	281010	2	INGRASSATORE	GRAISSEUR	SCHMIERER	GREASE FITTING	ENGRASADOR
12	136951	1	DISTANZIALE	ENTRETOISE	DISTANZSTÜCK	SPACER	DISTANCIADOR
13	137135	2	BOCCOLA	DOUILLE	BUCHSE	BUSHING	CASQUILLO
14	191168	3	DADO	ECROU	MUTTER	NUT	TUERCA
15	278093	1	KIT BRACCIO SECONDARIO	KIT BRAS SECONDAIRE	NEBENARMKIT	SECONDARY ARM KIT	KIT BRAZO SECUNDARIO
16	467575	1	SUPPORTO	SUPPORT	TRÄGER	SUPPORT	SOPORTE
17	497238	6	VITE	VIS	SCHRAUBE	SCREW	TORNILLO
18	417025	9	RONDELLA	RONDELLE	SCHEIBE	WASHER	ARANDELA
19	353080	1	MORSETTO	ETAU	KLEMME	CLAMP	PRENSOR
20	497136	1	VITE	VIS	SCHRAUBE	SCREW	TORNILLO
21	176388	2	CARTER	CARTER	GEHÄUSE	CASING	CARTER
22	380458	1	PERNO	AXE	BOLZEN	PIN	PERNO
23	310312	1	FERMO	ARRET	VERSTELLVORRICHTUNG	LOCK	TOPE
24	497129	2	VITE	VIS	SCHRAUBE	SCREW	TORNILLO
25	378063	1	PATTINO	PATIN	GLEITBLOCK	SLIDING BLOCK	PATIN



BRACCIO SECONDARIO (LC)

- * Bras secondaire
- * Nebenarm
- * Secondary arm
- * Brazo secundario

TAV. GG.02.02

matr. G107.0005

21
23 P

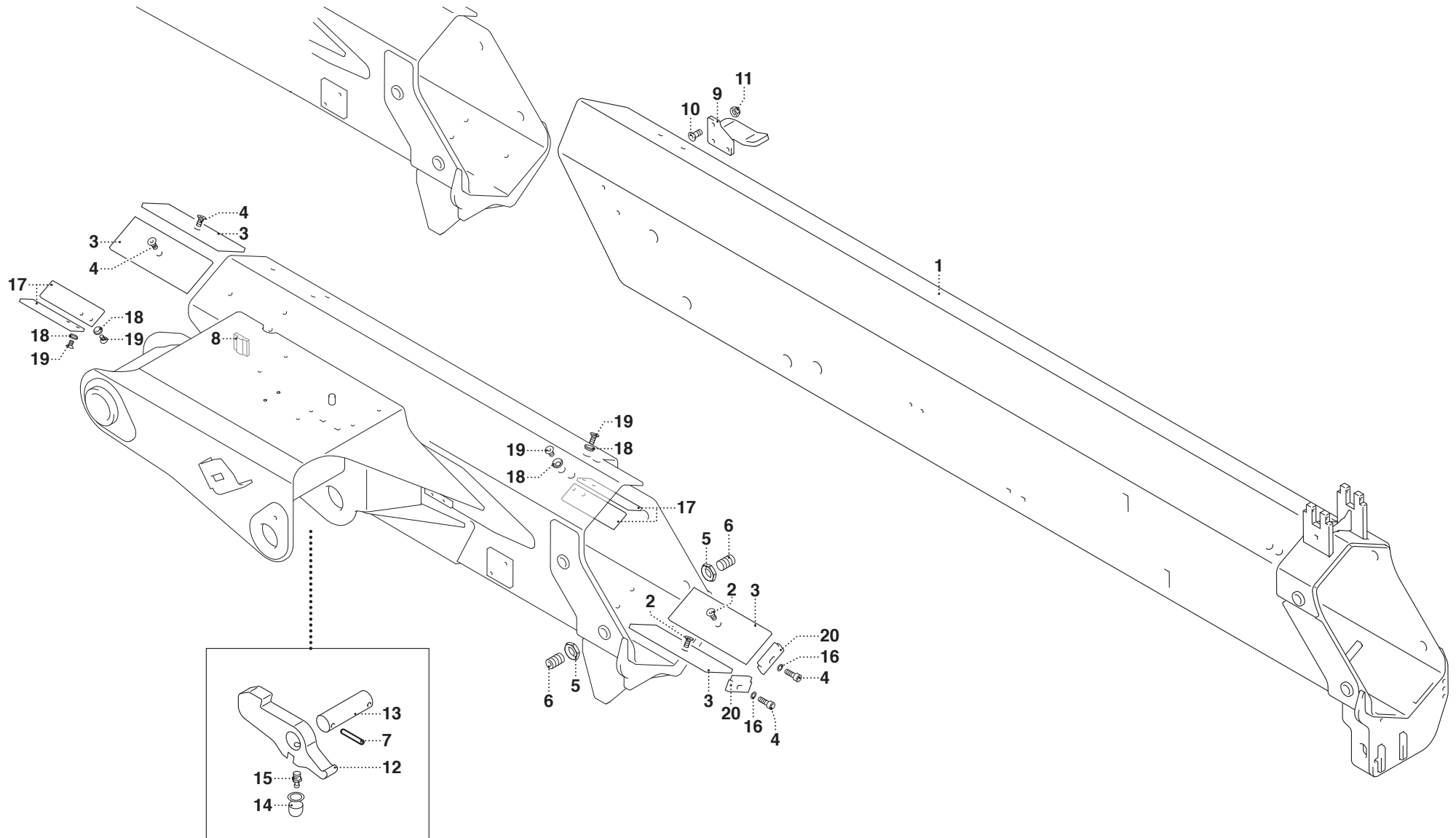

PM 21 LC - PM 23 P LC

matr. G107.0005

TAV. GG.02.02

POS.	N° CODICE	Q.	DESCRIZIONE	DESIGNATION	BENENNUNG	DESCRIPTION	DENOMINACIONES
1	142601	1	BRACCIO	BRAS	ARM	ARM	BRAZO
2	497908	4	VITE	VIS	SCHRAUBE	SCREW	TORNILLO
3	373931	4	PATTINO	PATIN	GLEITBLOCK	SLIDING BLOCK	PATIN
4	497383	2	VITE	VIS	SCHRAUBE	SCREW	TORNILLO
5	191213	4	DADO	ECROU	MUTTER	NUT	TUERCA
6	498156	4	VITE	VIS	SCHRAUBE	SCREW	TORNILLO
7	455221	2	SPINA	GOUPILLE	STIFT	PIN	PASADOR
8	373925	2	PATTINO	PATIN	GLEITBLOCK	SLIDING BLOCK	PATIN
9	467522	1	SUPPORTO	SUPPORT	TRÄGER	SUPPORT	SOPORTE
10	497499	3	VITE	VIS	SCHRAUBE	SCREW	TORNILLO
11	191168	3	DADO	ECROU	MUTTER	NUT	TUERCA
12	208246	1	FERMO	ARRET	VERSTELLVORRICHTUNG	LOCK	TOPE
13	380326	1	PERNO	AXE	BOLZEN	PIN	PERNO
14	471215	1	TAPPO	BOUCHON	VERSCHLUSSDECKEL	PLUG	TAPON
15	281010	1	INGRASSATORE	GRAISSEUR	SCHMIERER	GREASE FITTING	ENGRASADOR
16	417004	2	RONDELLA	RONDELLE	SCHEIBE	WASHER	ARANDELA
17	373660	4	PATTINO	PATIN	GLEITBLOCK	SLIDING BLOCK	PATIN
18	140026	8	RONDELLA	RONDELLE	SCHEIBE	WASHER	ARANDELA
19	497909	8	VITE	VIS	SCHRAUBE	SCREW	TORNILLO
20	208280	2	FERMO	ARRET	VERSTELLVORRICHTUNG	LOCK	TOPE



BRACCIO SECONDARIO (LC)

* Bras secondaire
* Nebenarm
* Secondary arm
* Brazo secundario

TAV. GG.02.02A

matr. G107.0069

21
23 P

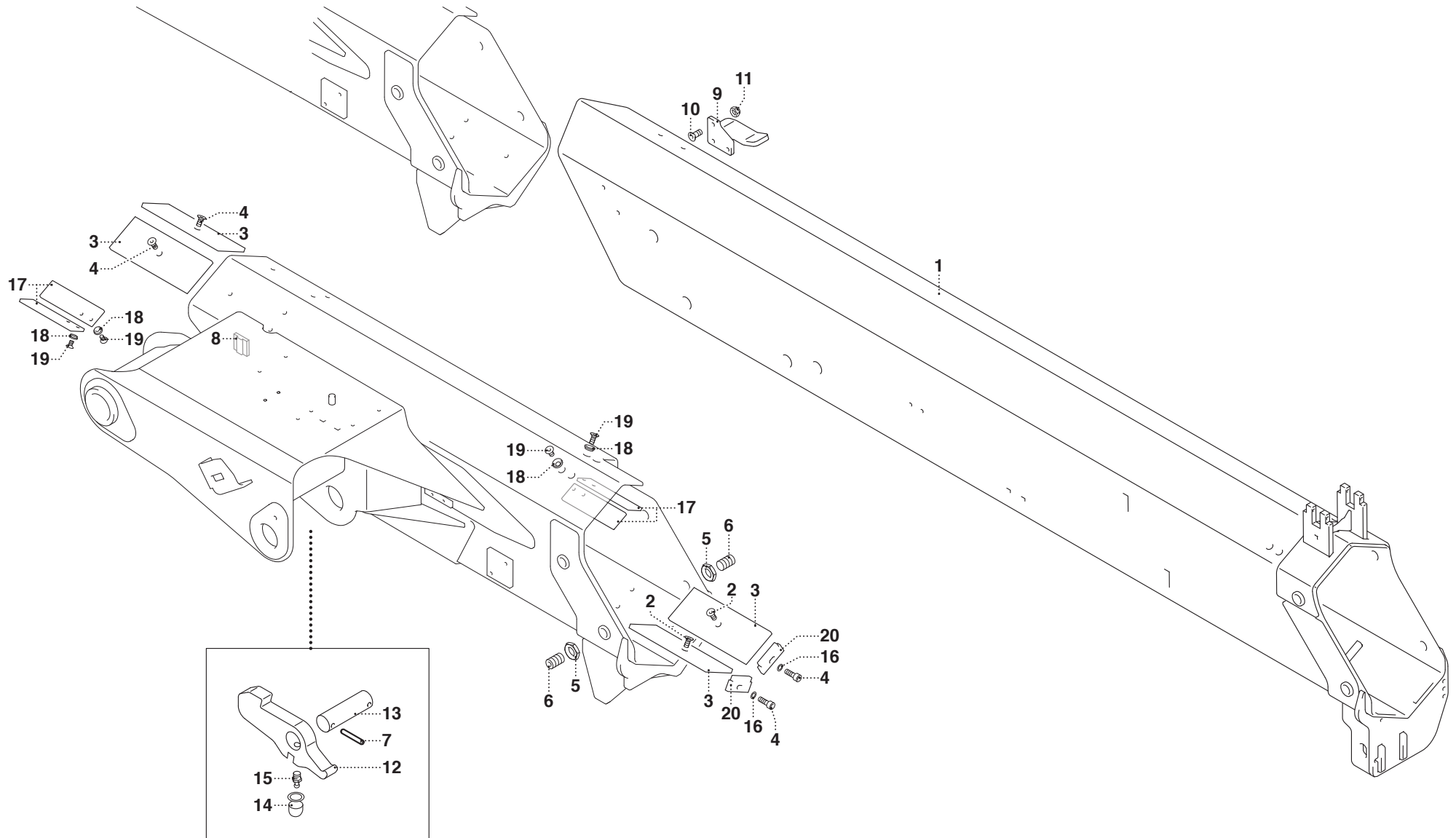

PM 21 LC - PM 23 P LC

matr. G107.0069

TAV. GG.02.02A

POS.	N° CODICE	Q.	DESCRIZIONE	DESIGNATION	BENENNUNG	DESCRIPTION	DENOMINACIONES
1	142675	1	BRACCIO	BRAS	ARM	ARM	BRAZO
2	497908	4	VITE	VIS	SCHRAUBE	SCREW	TORNILLO
3	373931	4	PATTINO	PATIN	GLEITBLOCK	SLIDING BLOCK	PATIN
4	497383	2	VITE	VIS	SCHRAUBE	SCREW	TORNILLO
5	191213	4	DADO	ECROU	MUTTER	NUT	TUERCA
6	498156	4	VITE	VIS	SCHRAUBE	SCREW	TORNILLO
7	455221	2	SPINA	GOUPILLE	STIFT	PIN	PASADOR
8	373925	2	PATTINO	PATIN	GLEITBLOCK	SLIDING BLOCK	PATIN
9	467522	1	SUPPORTO	SUPPORT	TRÄGER	SUPPORT	SOPORTE
10	497499	3	VITE	VIS	SCHRAUBE	SCREW	TORNILLO
11	191168	3	DADO	ECROU	MUTTER	NUT	TUERCA
12	208246	1	FERMO	ARRET	VERSTELLVORRICHTUNG	LOCK	TOPE
13	380326	1	PERNO	AXE	BOLZEN	PIN	PERNO
14	471215	1	TAPPO	BOUCHON	VERSCHLUSSDECKEL	PLUG	TAPON
15	281010	1	INGRASSATORE	GRAISSEUR	SCHMIERER	GREASE FITTING	ENGRASADOR
16	417004	2	RONDELLA	RONDELLE	SCHEIBE	WASHER	ARANDELA
17	373660	4	PATTINO	PATIN	GLEITBLOCK	SLIDING BLOCK	PATIN
18	140026	8	RONDELLA	RONDELLE	SCHEIBE	WASHER	ARANDELA
19	497909	8	VITE	VIS	SCHRAUBE	SCREW	TORNILLO
20	208280	2	FERMO	ARRET	VERSTELLVORRICHTUNG	LOCK	TOPE



1° BRACCIO SFILO IDRAULICO

- * 1er bras - extension hydraulique
- * 1. Arm - hydraulische Ausziehen
- * 1st arm - hydraulic extension
- * 1er brazo - extensión hidráulica

TAV. GG.03.01

matr. G107.0005

21
23 P

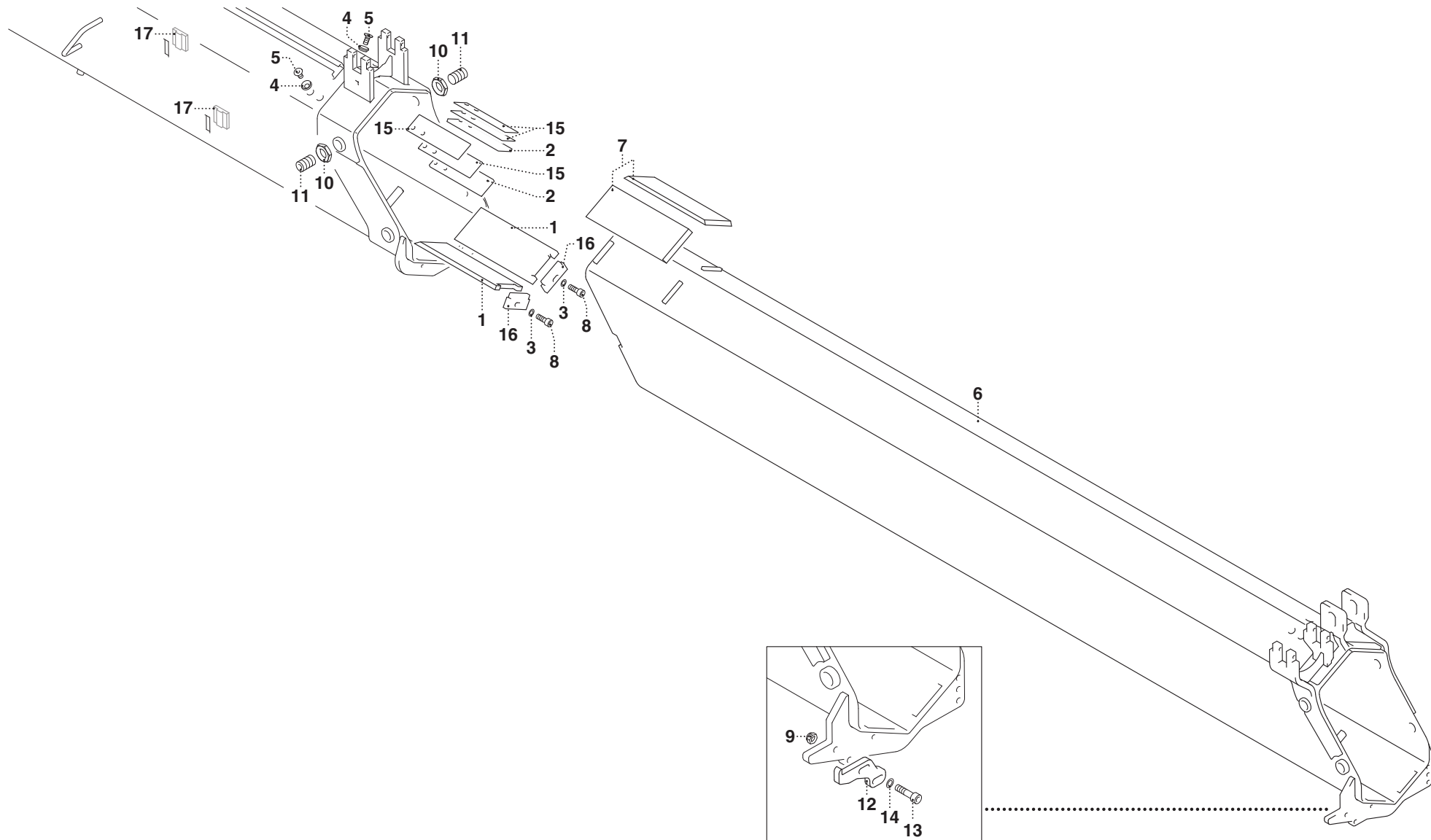

PM 21 - PM 23 P**matr. G107.0005****TAV. GG.03.01**

POS.	N° CODICE	Q.	DESCRIZIONE	DESIGNATION	BENENNUNG	DESCRIPTION	DENOMINACIONES
1	373990	2	PATTINO	PATIN	GLEITBLOCK	SLIDING BLOCK	PATIN
2	373660	2	PATTINO	PATIN	GLEITBLOCK	SLIDING BLOCK	PATIN
3	417004	2	RONDELLA	RONDELLE	SCHEIBE	WASHER	ARANDELA
4	140026	4	BORCHIA	BOSSETTE	WARZE	STUD	BULLON
5	497909	4	VITE	VIS	SCHRAUBE	SCREW	TORNILLO
6	142481	1	BRACCIO	BRAS	ARM	ARM	BRAZO
7	373989	2	PATTINO	PATIN	GLEITBLOCK	SLIDING BLOCK	PATIN
8	497383	2	VITE	VIS	SCHRAUBE	SCREW	TORNILLO
9	191168	2	DADO	ECROU	MUTTER	NUT	TUERCA
10	191213	4	DADO	ECROU	MUTTER	NUT	TUERCA
11	498156	4	VITE	VIS	SCHRAUBE	SCREW	TORNILLO
12	467523	1	SUPPORTO	SUPPORT	TRÄGER	SUPPORT	SOPORTE
13	497134	2	VITE	VIS	SCHRAUBE	SCREW	TORNILLO
14	417025	2	RONDELLA	RONDELLE	SCHEIBE	WASHER	ARANDELA
15	294254	4	SPESSORE	EPAISSEUR	DICKE	THICKNESS	ESPEJOR
16	208280	2	FERMO	ARRET	VERSTELLVORRICHTUNG	LOCK	TOPE
17	373924	4	PATTINO	PATIN	GLEITBLOCK	SLIDING BLOCK	PATIN



2° BRACCIO SFILO IDRAULICO (21023-24-25-26-27 - 23023-24-25-26-27 P)

- * 2ème bras - extension hydraulique
- * 2. Arm - hydraulische Ausziehen
- * 2nd arm - hydraulic extension
- * 2do brazo - extensión hidráulica

TAV. GG.04.01

matr. G107.0005

21
23 P

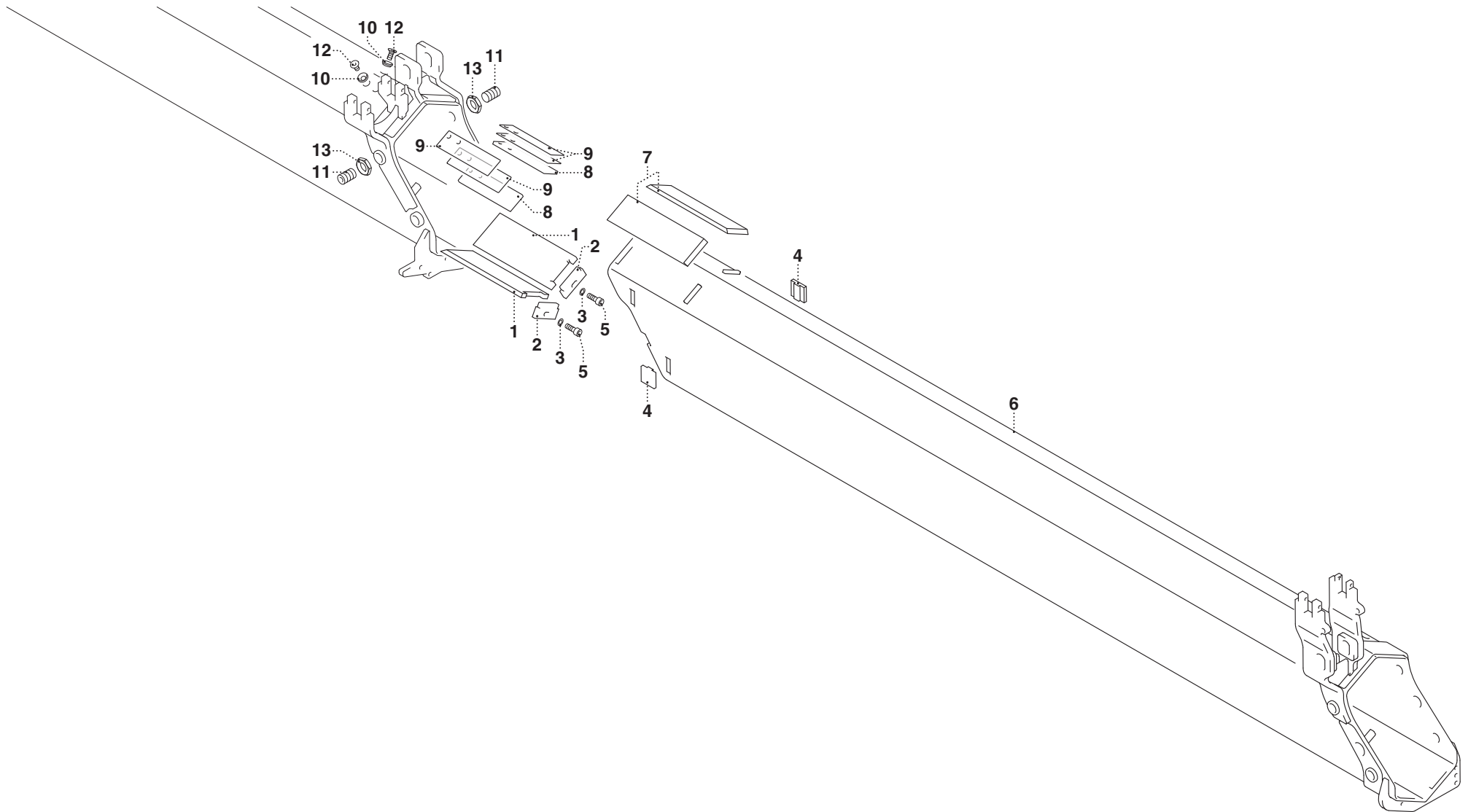

PM 21023-24-25-26-27 - PM 23023-24-25-26-27 P

matr. G107.0005

TAV. GG.04.01

POS.	N° CODICE	Q.	DESCRIZIONE	DESIGNATION	BENENNUNG	DESCRIPTION	DENOMINACIONES
1	373990	2	PATTINO	PATIN	GLEITBLOCK	SLIDING BLOCK	PATIN
2	208280	2	FERMO	ARRET	VERSTELLVORRICHTUNG	LOCK	TOPE
3	417004	2	RONDELLA	RONDELLE	SCHEIBE	WASHER	ARANDELA
4	373924	2	PATTINO	PATIN	GLEITBLOCK	SLIDING BLOCK	PATIN
5	497383	2	VITE	VIS	SCHRAUBE	SCREW	TORNILLO
6	142482	1	BRACCIO	BRAS	ARM	ARM	BRAZO
7	373991	2	PATTINO	PATIN	GLEITBLOCK	SLIDING BLOCK	PATIN
8	373660	2	PATTINO	PATIN	GLEITBLOCK	SLIDING BLOCK	PATIN
9	294254	4	SPESSORE	EPAISSEUR	DICKE	THICKNESS	ESPEJOR
10	140026	4	BORCHIA	BOSSETTE	WARZE	STUD	BULLON
11	498156	4	VITE	VIS	SCHRAUBE	SCREW	TORNILLO
12	497909	4	VITE	VIS	SCHRAUBE	SCREW	TORNILLO
13	191213	4	DADO	ECROU	MUTTER	NUT	TUERCA



2° BRACCIO SFILÒ IDRAULICO (21022 - 23022 P)

- * 2ème bras - extension hydraulique
- * 2. Arm - hydraulische Ausziehen
- * 2nd arm - hydraulic extension
- * 2do brazo - extensión hidráulica

TAV. GG.04.02

matr. G107.0005

21
23 P

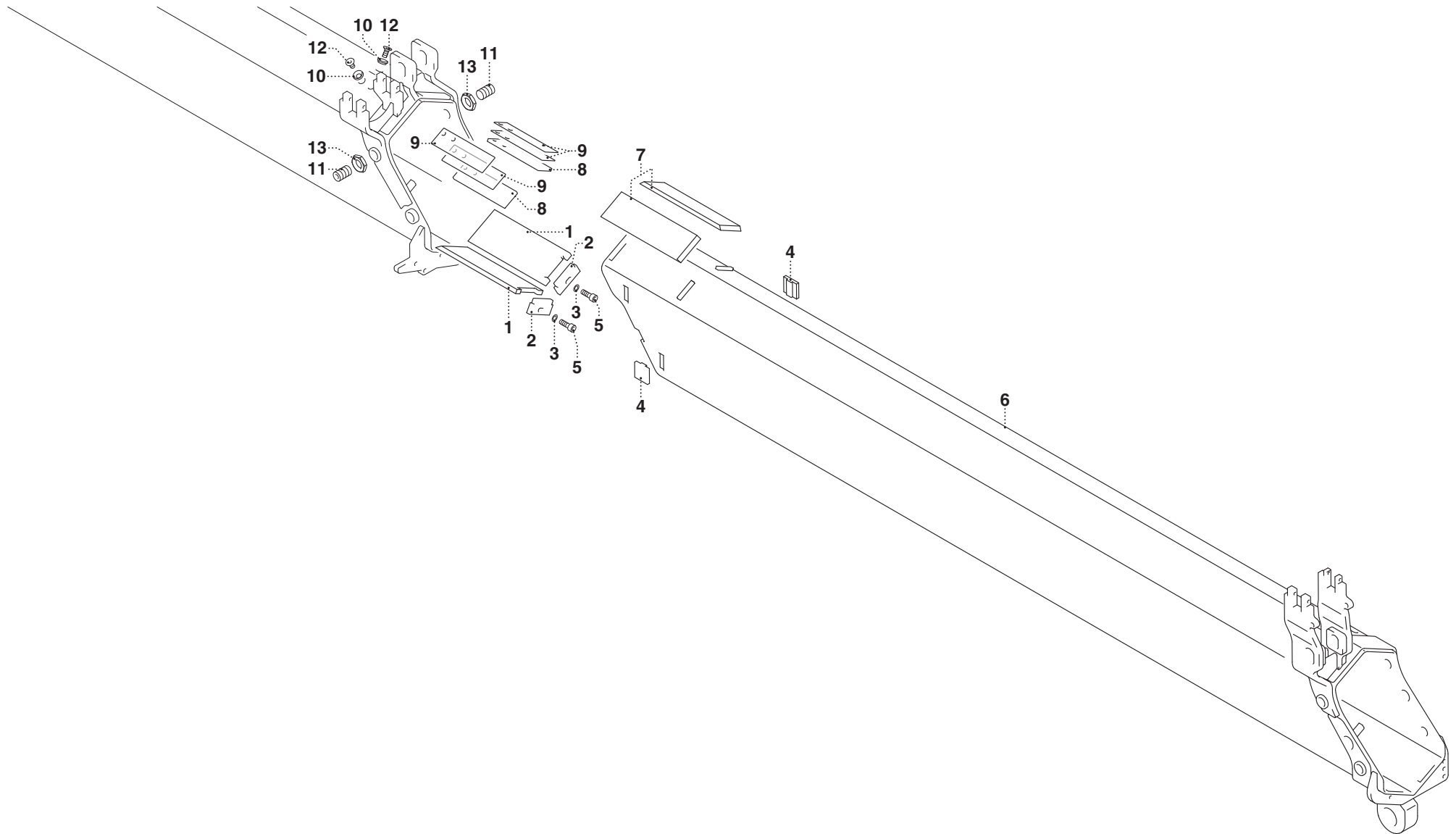

PM 21022 - PM 23022 P

matr. G107.0005

TAV. GG.04.02

POS.	N° CODICE	Q.	DESCRIZIONE	DESIGNATION	BENENNUNG	DESCRIPTION	DENOMINACIONES
1	373990	2	PATTINO	PATIN	GLEITBLOCK	SLIDING BLOCK	PATIN
2	208280	2	FERMO	ARRET	VERSTELLVORRICHTUNG	LOCK	TOPE
3	417004	2	RONDELLA	RONDELLE	SCHEIBE	WASHER	ARANDELA
4	373924	2	PATTINO	PATIN	GLEITBLOCK	SLIDING BLOCK	PATIN
5	497383	2	VITE	VIS	SCHRAUBE	SCREW	TORNILLO
6	142488	1	BRACCIO	BRAS	ARM	ARM	BRAZO
7	373991	2	PATTINO	PATIN	GLEITBLOCK	SLIDING BLOCK	PATIN
8	373660	2	PATTINO	PATIN	GLEITBLOCK	SLIDING BLOCK	PATIN
9	294254	4	SPESSORE	EPAISSEUR	DICKE	THICKNESS	ESPEJOR
10	140026	4	BORCHIA	BOSSETTE	WARZE	STUD	BULLON
11	498156	4	VITE	VIS	SCHRAUBE	SCREW	TORNILLO
12	497909	4	VITE	VIS	SCHRAUBE	SCREW	TORNILLO
13	191213	4	DADO	ECROU	MUTTER	NUT	TUERCA



3° BRACCIO SFILLO IDRAULICO (21024-25-26-27 - 23024-25-26-27 P)

- * 3ème bras - extension hydraulique
- * 3. Arm - hydraulische Ausziehen
- * 3rd arm - hydraulic extension
- * 3ero brazo - extensión hidráulica

TAV. GG.05.01

matr. G107.0005

21
23 P

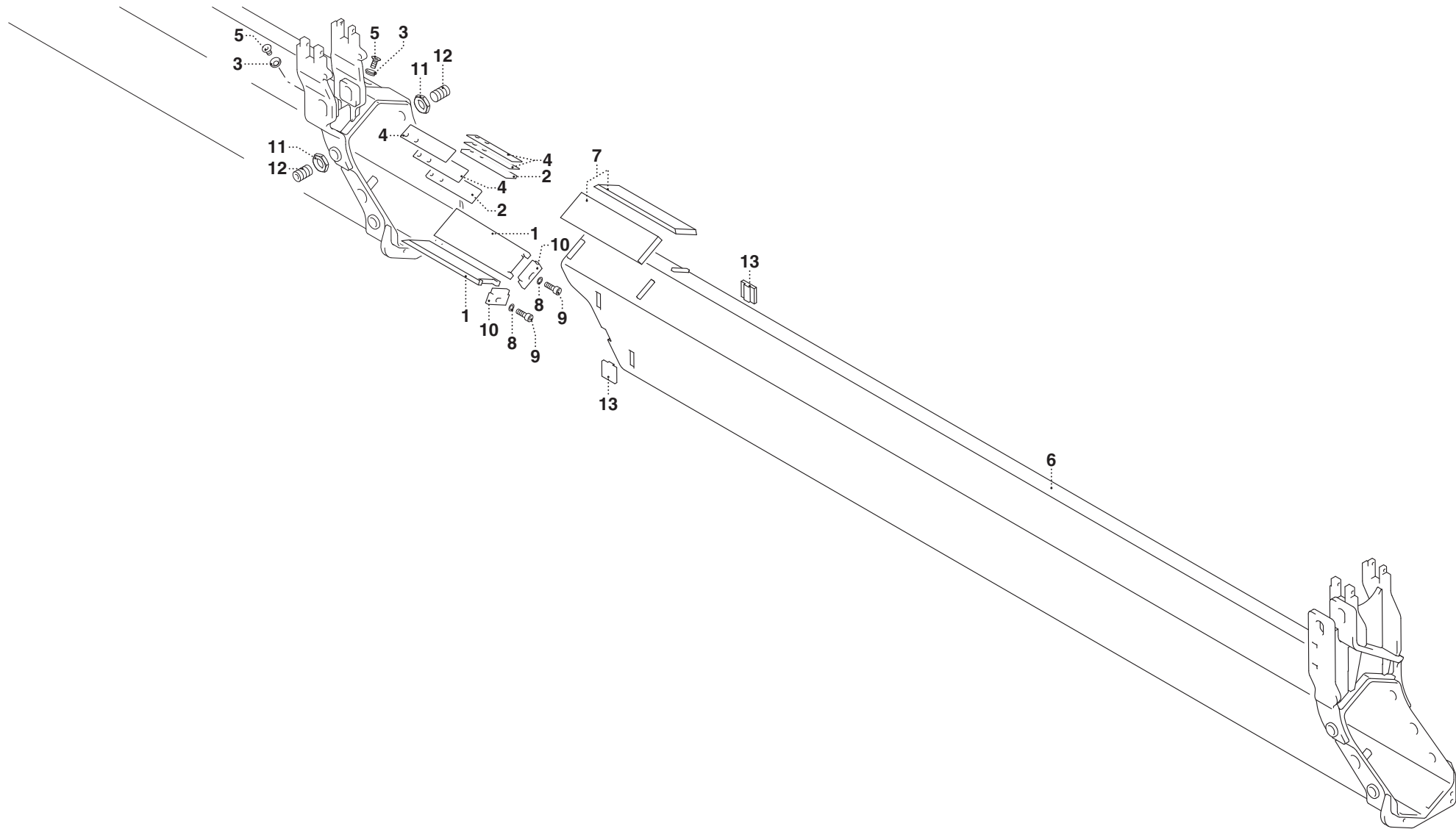

PM 21024-25-26-27 - PM 23024-25-26-27 P

matr. G107.0005

TAV. GG.05.01

POS.	N° CODICE	Q.	DESCRIZIONE	DESIGNATION	BENENNUNG	DESCRIPTION	DENOMINACIONES
1	373992	2	PATTINO	PATIN	GLEITBLOCK	SLIDING BLOCK	PATIN
2	373927	2	PATTINO	PATIN	GLEITBLOCK	SLIDING BLOCK	PATIN
3	140026	4	BORCHIA	BOSSETTE	WARZE	STUD	BULLON
4	308992	4	SPESSORE	EPAISSEUR	DICKE	THICKNESS	ESPESOR
5	497909	4	VITE	VIS	SCHRAUBE	SCREW	TORNILLO
6	142483	1	BRACCIO	BRAS	ARM	ARM	BRAZO
7	373991	2	PATTINO	PATIN	GLEITBLOCK	SLIDING BLOCK	PATIN
8	417004	2	RONDELLA	RONDELLE	SCHEIBE	WASHER	ARANDELA
9	497383	2	VITE	VIS	SCHRAUBE	SCREW	TORNILLO
10	208281	2	FERMO	ARRET	VERSTELLVORRICHTUNG	LOCK	TOPE
11	191213	4	DADO	ECROU	MUTTER	NUT	TUERCA
12	498156	4	VITE	VIS	SCHRAUBE	SCREW	TORNILLO
13	373924	4	PATTINO	PATIN	GLEITBLOCK	SLIDING BLOCK	PATIN



3° BRACCIO SFILO IDRAULICO (21023 - 23023 P)

- * 3ème bras - extension hydraulique
- * 3. Arm - hydraulische Ausziehen
- * 3rd arm - hydraulic extension
- * 3ero brazo - extensión hidráulica

TAV. GG.05.02

matr. G107.0005

21
23 P

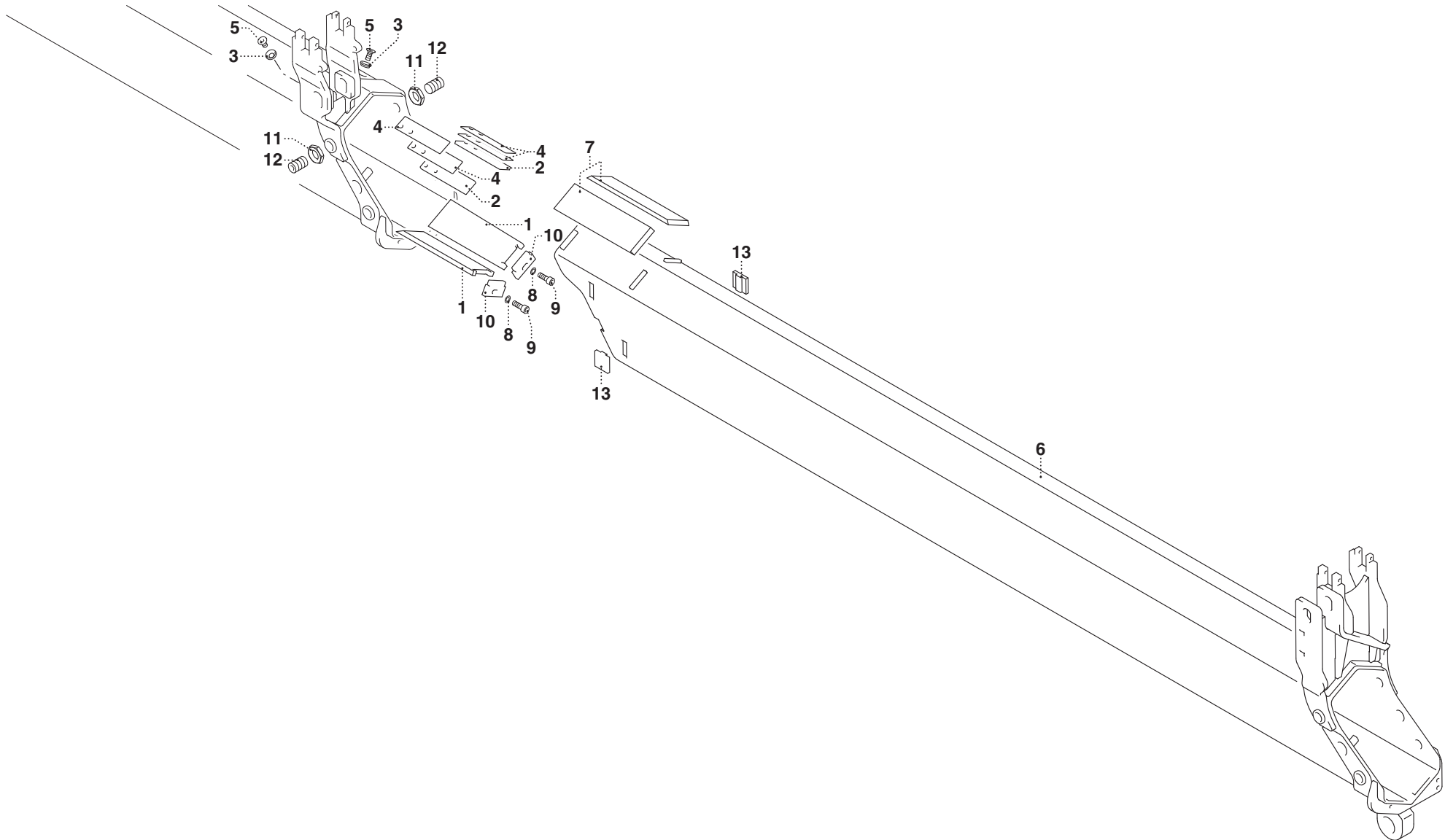

PM 21023 - PM 23023 P**matr. G107.0005****TAV. GG.05.02**

POS.	N° CODICE	Q.	DESCRIZIONE	DESIGNATION	BENENNUNG	DESCRIPTION	DENOMINACIONES
1	373992	2	PATTINO	PATIN	GLEITBLOCK	SLIDING BLOCK	PATIN
2	373927	2	PATTINO	PATIN	GLEITBLOCK	SLIDING BLOCK	PATIN
3	140026	4	BORCHIA	BOSSETTE	WARZE	STUD	BULLON
4	308992	4	SPESSORE	EPAISSEUR	DICKE	THICKNESS	ESPESOR
5	497909	4	VITE	VIS	SCHRAUBE	SCREW	TORNILLO
6	142489	1	BRACCIO	BRAS	ARM	ARM	BRAZO
7	373991	2	PATTINO	PATIN	GLEITBLOCK	SLIDING BLOCK	PATIN
8	417004	2	RONDELLA	RONDELLE	SCHEIBE	WASHER	ARANDELA
9	497383	2	VITE	VIS	SCHRAUBE	SCREW	TORNILLO
10	208281	2	FERMO	ARRET	VERSTELLVORRICHTUNG	LOCK	TOPE
11	191213	4	DADO	ECROU	MUTTER	NUT	TUERCA
12	498156	4	VITE	VIS	SCHRAUBE	SCREW	TORNILLO
13	373924	4	PATTINO	PATIN	GLEITBLOCK	SLIDING BLOCK	PATIN



4° BRACCIO SFILLO IDRAULICO (21025-26-27 - 23025-26-27 P)

- * 4ème bras - extension hydraulique
- * 4. Arm - hydraulische Ausziehen
- * 4th arm - hydraulic extension
- * 4to brazo - extensión hidráulica

TAV. GG.06.01

matr. G107.0005

21
23 P

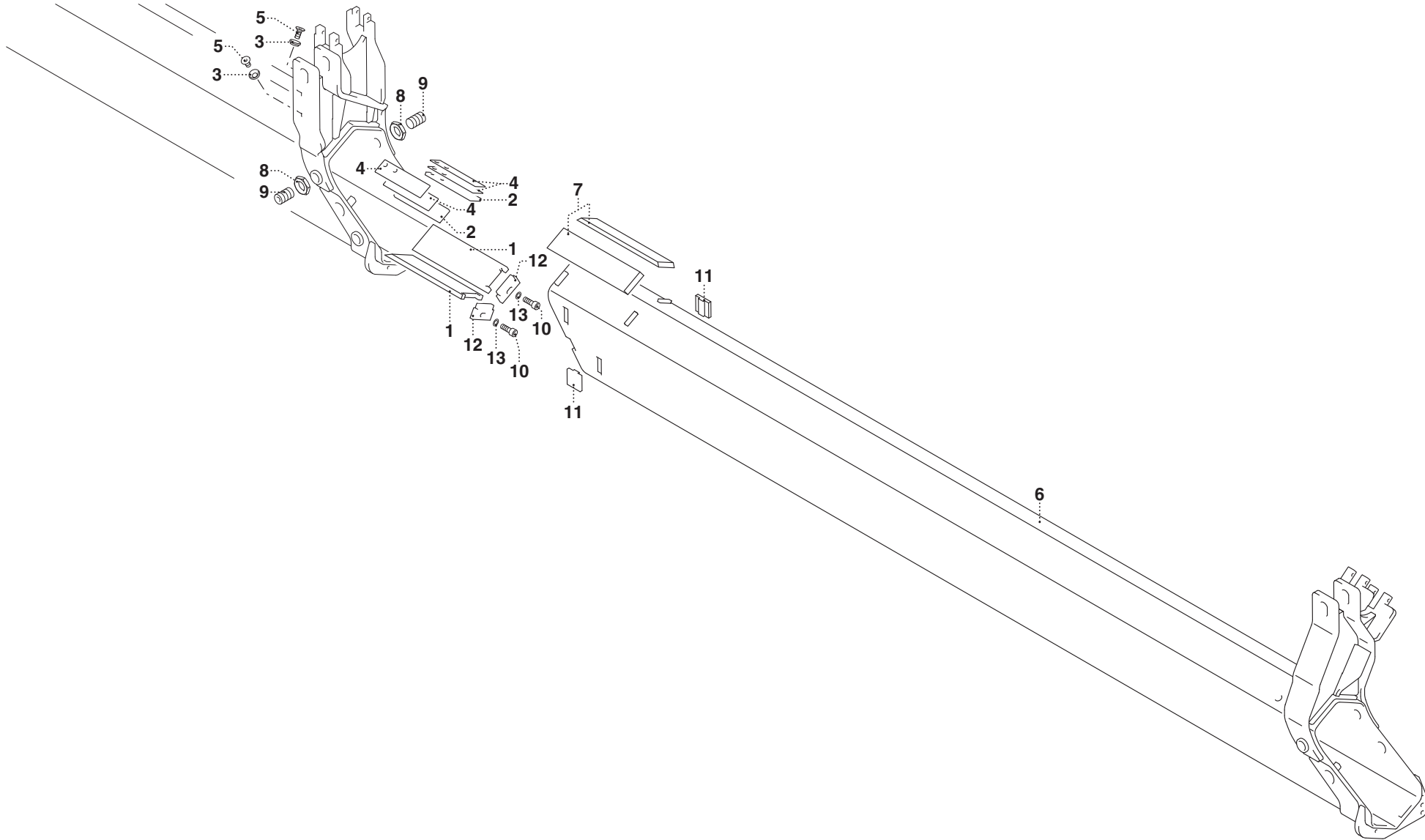

PM 21025-26-27 - PM 23025-26-27 P

matr. G107.0005

TAV. GG.06.01

POS.	N° CODICE	Q.	DESCRIZIONE	DESIGNATION	BENENNUNG	DESCRIPTION	DENOMINACIONES
1	373992	2	PATTINO	PATIN	GLEITBLOCK	SLIDING BLOCK	PATIN
2	373927	2	PATTINO	PATIN	GLEITBLOCK	SLIDING BLOCK	PATIN
3	140026	4	BORCHIA	BOSSETTE	WARZE	STUD	BULLON
4	308992	4	SPESSORE	EPAISSEUR	DICKE	THICKNESS	ESPESOR
5	497909	4	VITE	VIS	SCHRAUBE	SCREW	TORNILLO
6	142484	1	BRACCIO	BRAS	ARM	ARM	BRAZO
7	373993	2	PATTINO	PATIN	GLEITBLOCK	SLIDING BLOCK	PATIN
8	191213	4	DADO	ECROU	MUTTER	NUT	TUERCA
9	498156	4	VITE	VIS	SCHRAUBE	SCREW	TORNILLO
10	497383	2	VITE	VIS	SCHRAUBE	SCREW	TORNILLO
11	373924	4	PATTINO	PATIN	GLEITBLOCK	SLIDING BLOCK	PATIN
12	208281	2	FERMO	ARRET	VERSTELLVORRICHTUNG	LOCK	TOPE
13	417004	2	RONDELLA	RONDELLE	SCHEIBE	WASHER	ARANDELA



4° BRACCIO SFILO IDRAULICO (21024 - 23024 P)

- * 4ème bras - extension hydraulique
- * 4. Arm - hydraulische Ausziehen
- * 4th arm - hydraulic extension
- * 4to brazo - extensión hidráulica

TAV. GG.06.02

matr. G107.0005

21
23 P

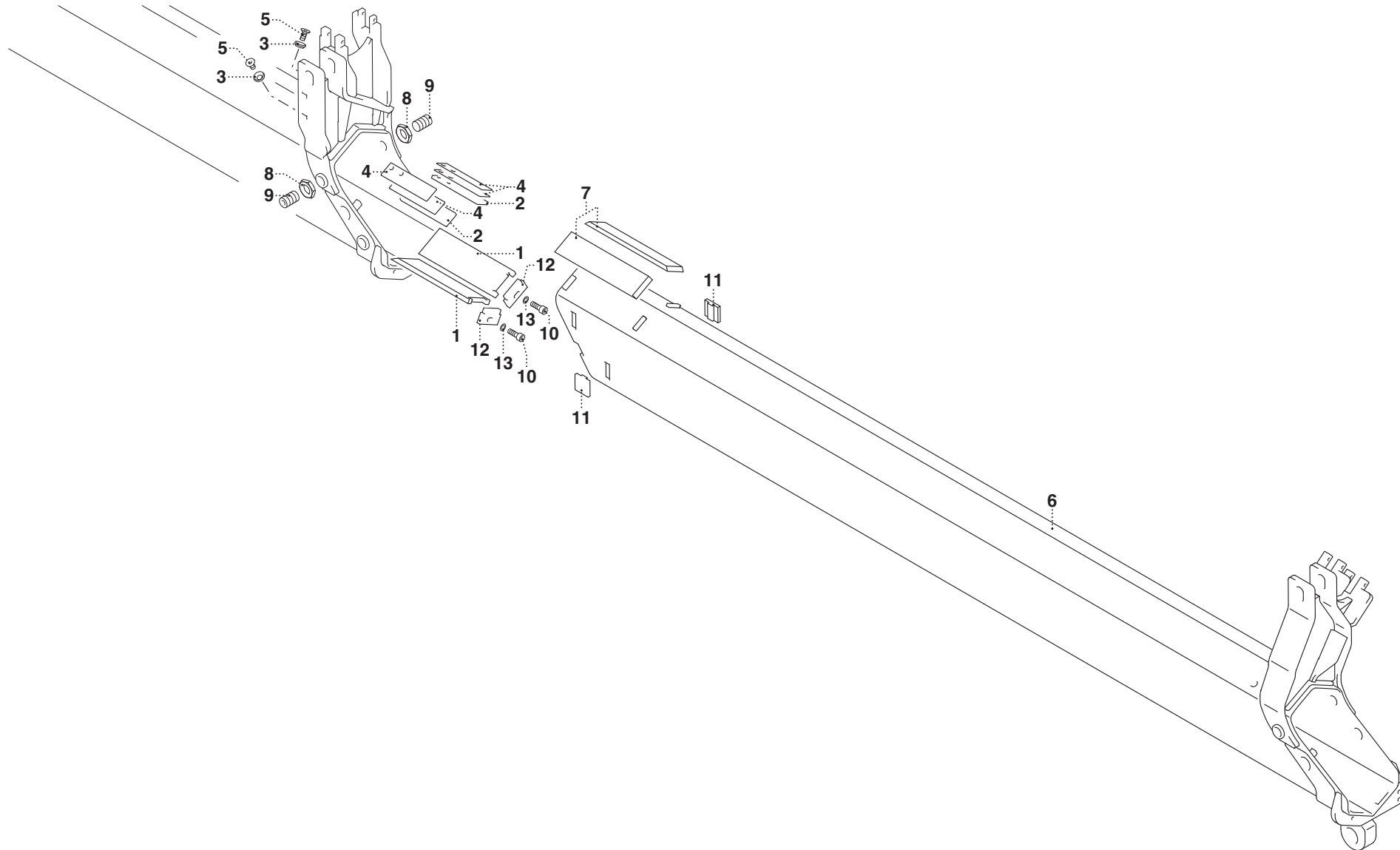

PM 21024 - PM 23024 P**matr. G107.0005****TAV. GG.06.02**

POS.	N° CODICE	Q.	DESCRIZIONE	DESIGNATION	BENENNUNG	DESCRIPTION	DENOMINACIONES
1	373992	2	PATTINO	PATIN	GLEITBLOCK	SLIDING BLOCK	PATIN
2	373927	2	PATTINO	PATIN	GLEITBLOCK	SLIDING BLOCK	PATIN
3	140026	4	BORCHIA	BOSSETTE	WARZE	STUD	BULLON
4	308992	4	SPESSORE	EPAISSEUR	DICKE	THICKNESS	ESPESOR
5	497909	4	VITE	VIS	SCHRAUBE	SCREW	TORNILLO
6	142490	1	BRACCIO	BRAS	ARM	ARM	BRAZO
7	373993	2	PATTINO	PATIN	GLEITBLOCK	SLIDING BLOCK	PATIN
8	191213	4	DADO	ECROU	MUTTER	NUT	TUERCA
9	498156	4	VITE	VIS	SCHRAUBE	SCREW	TORNILLO
10	497383	2	VITE	VIS	SCHRAUBE	SCREW	TORNILLO
11	373924	4	PATTINO	PATIN	GLEITBLOCK	SLIDING BLOCK	PATIN
12	208281	2	FERMO	ARRET	VERSTELLVORRICHTUNG	LOCK	TOPE
13	417004	2	RONDELLA	RONDELLE	SCHEIBE	WASHER	ARANDELA



5° BRACCIO SFILO IDRAULICO (21026-27 - 23026-27 P)

- * 5ème bras - extension hydraulique
- * 5. Arm - hydraulische Ausziehen
- * 5th arm - hydraulic extension
- * 5to brazo - extensión hidráulica

TAV. GG.07.01

matr. G107.0005

21
23 P

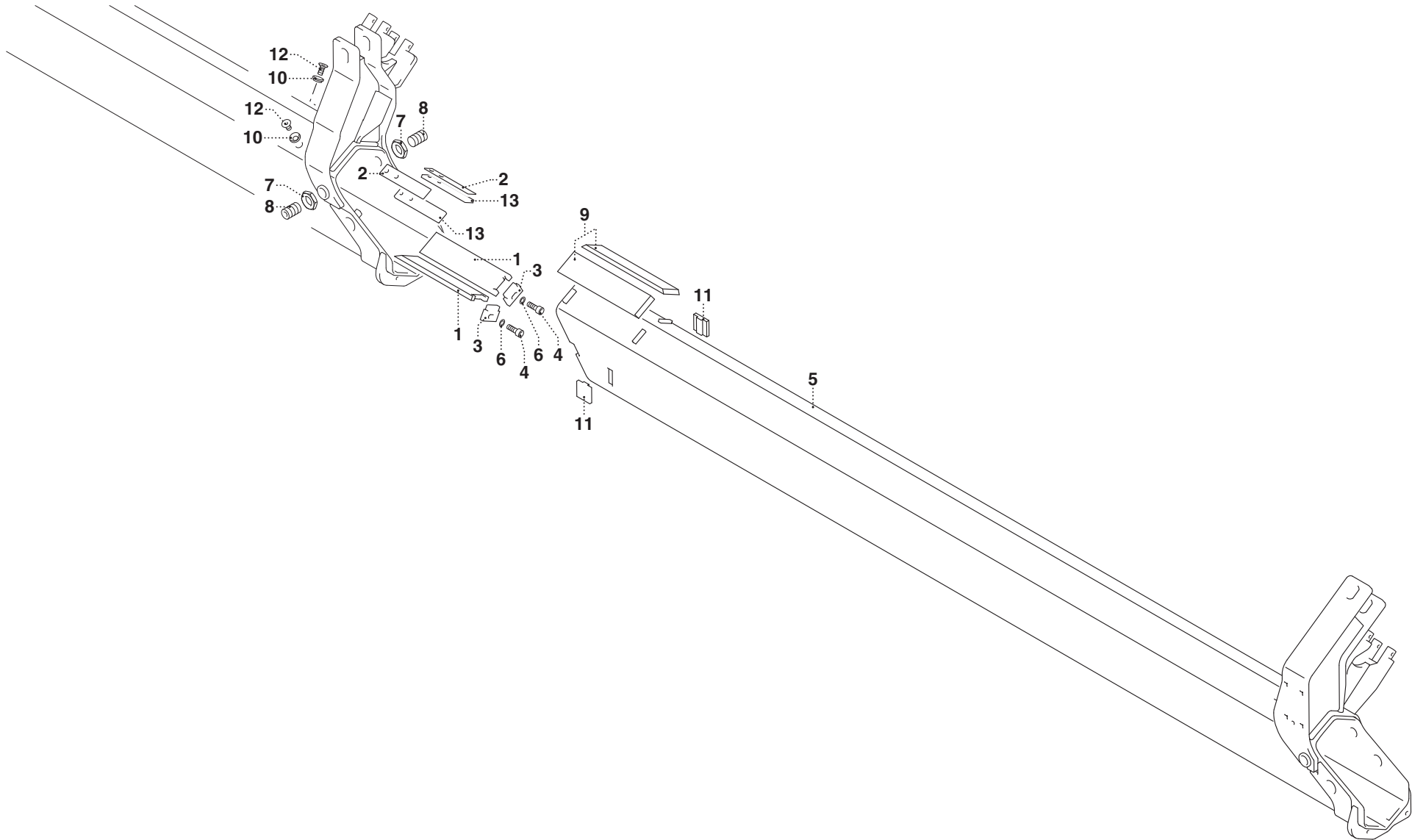

PM 21026-27 - PM 23026-27 P

matr. G107.0005

TAV. GG.07.01

POS.	N° CODICE	Q.	DESCRIZIONE	DESIGNATION	BENENNUNG	DESCRIPTION	DENOMINACIONES
1	373994	2	PATTINO	PATIN	GLEITBLOCK	SLIDING BLOCK	PATIN
2	304384	2	SPESSORE	EPAISSEUR	DICKE	THICKNESS	ESPEJOR
3	208282	2	FERMO	ARRET	VERSTELLVORRICHTUNG	LOCK	TOPE
4	497383	2	VITE	VIS	SCHRAUBE	SCREW	TORNILLO
5	142485	1	BRACCIO	BRAS	ARM	ARM	BRAZO
6	417004	2	RONDELLA	RONDELLE	SCHEIBE	WASHER	ARANDELA
7	191213	2	DADO	ECROU	MUTTER	NUT	TUERCA
8	498156	2	VITE	VIS	SCHRAUBE	SCREW	TORNILLO
9	373993	2	PATTINO	PATIN	GLEITBLOCK	SLIDING BLOCK	PATIN
10	140026	4	BORCHIA	BOSSETTE	WARZE	STUD	BULLON
11	373924	2	PATTINO	PATIN	GLEITBLOCK	SLIDING BLOCK	PATIN
12	497909	4	VITE	VIS	SCHRAUBE	SCREW	TORNILLO
13	373837	2	PATTINO	PATIN	GLEITBLOCK	SLIDING BLOCK	PATIN



5° BRACCIO SFILO IDRAULICO (21025 - 23025 P)

- * 5ème bras - extension hydraulique
- * 5. Arm - hydraulische Ausziehen
- * 5th arm - hydraulic extension
- * 5to brazo - extensión hidráulica

TAV. GG.07.02

matr. G107.0005

21
23 P

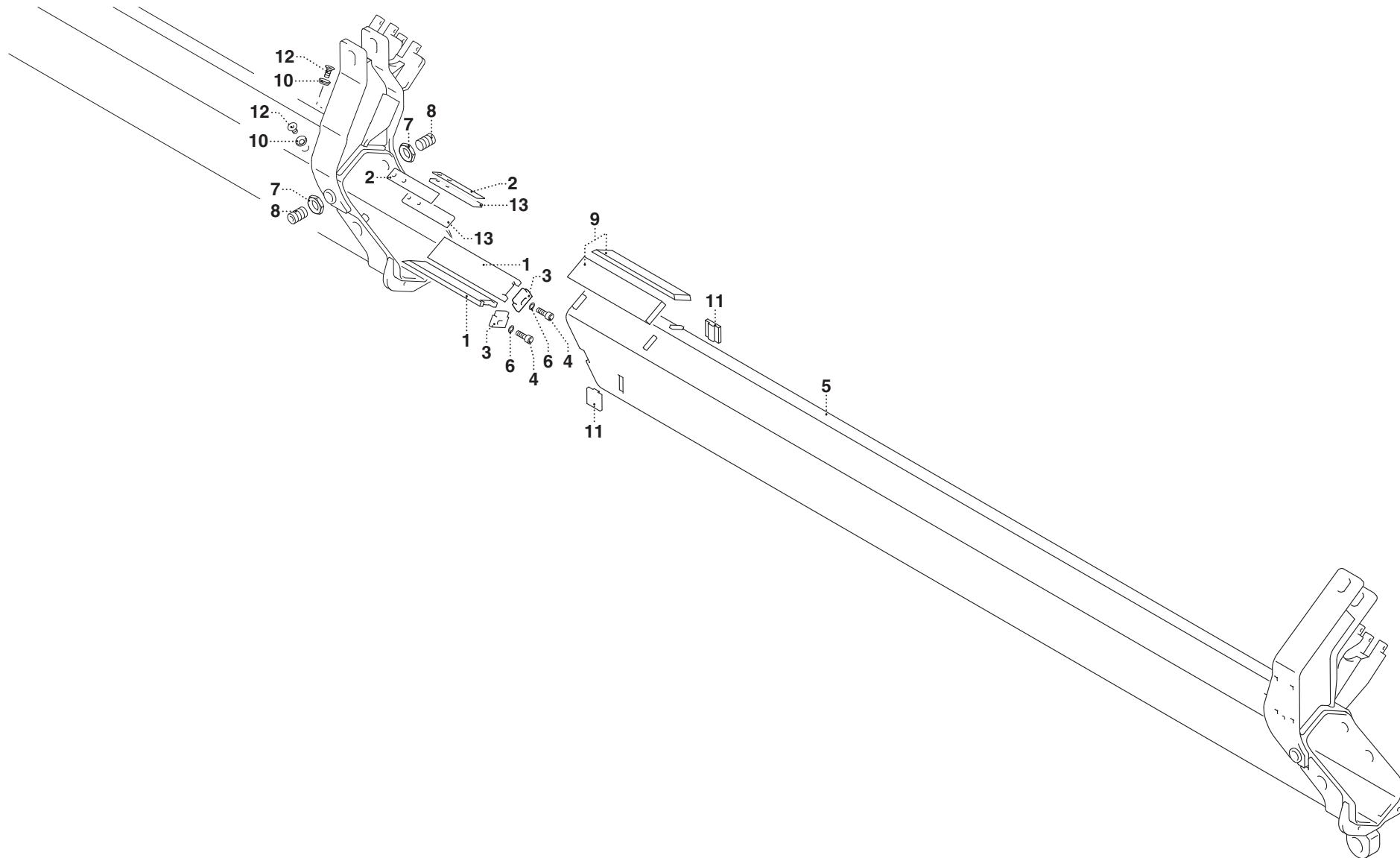

PM 21025 - PM 23025 P

matr. G107.0005

TAV. GG.07.02

POS.	N° CODICE	Q.	DESCRIZIONE	DESIGNATION	BENENNUNG	DESCRIPTION	DENOMINACIONES
1	378016	2	PATTINO	PATIN	GLEITBLOCK	SLIDING BLOCK	PATIN
2	304384	2	SPESSORE	EPAISSEUR	DICKE	THICKNESS	ESPEJOR
3	208282	2	FERMO	ARRET	VERSTELLVORRICHTUNG	LOCK	TOPE
4	497383	2	VITE	VIS	SCHRAUBE	SCREW	TORNILLO
5	142491	1	BRACCIO	BRAS	ARM	ARM	BRAZO
6	417004	2	RONDELLA	RONDELLE	SCHEIBE	WASHER	ARANDELA
7	191213	2	DADO	ECROU	MUTTER	NUT	TUERCA
8	498156	2	VITE	VIS	SCHRAUBE	SCREW	TORNILLO
9	378002	2	PATTINO	PATIN	GLEITBLOCK	SLIDING BLOCK	PATIN
10	140026	4	BORCHIA	BOSSETTE	WARZE	STUD	BULLON
11	373924	2	PATTINO	PATIN	GLEITBLOCK	SLIDING BLOCK	PATIN
12	497909	4	VITE	VIS	SCHRAUBE	SCREW	TORNILLO
13	373837	2	PATTINO	PATIN	GLEITBLOCK	SLIDING BLOCK	PATIN



6° BRACCIO SFILÒ IDRAULICO (21027 - 23027 P)

- * 6ème bras - extension hydraulique
- * 6. Arm - hydraulische Ausziehen
- * 6th arm - hydraulic extension
- * 6to brazo - extensión hidráulica

TAV. GG.08.01

matr. G107.0005

21
23 P

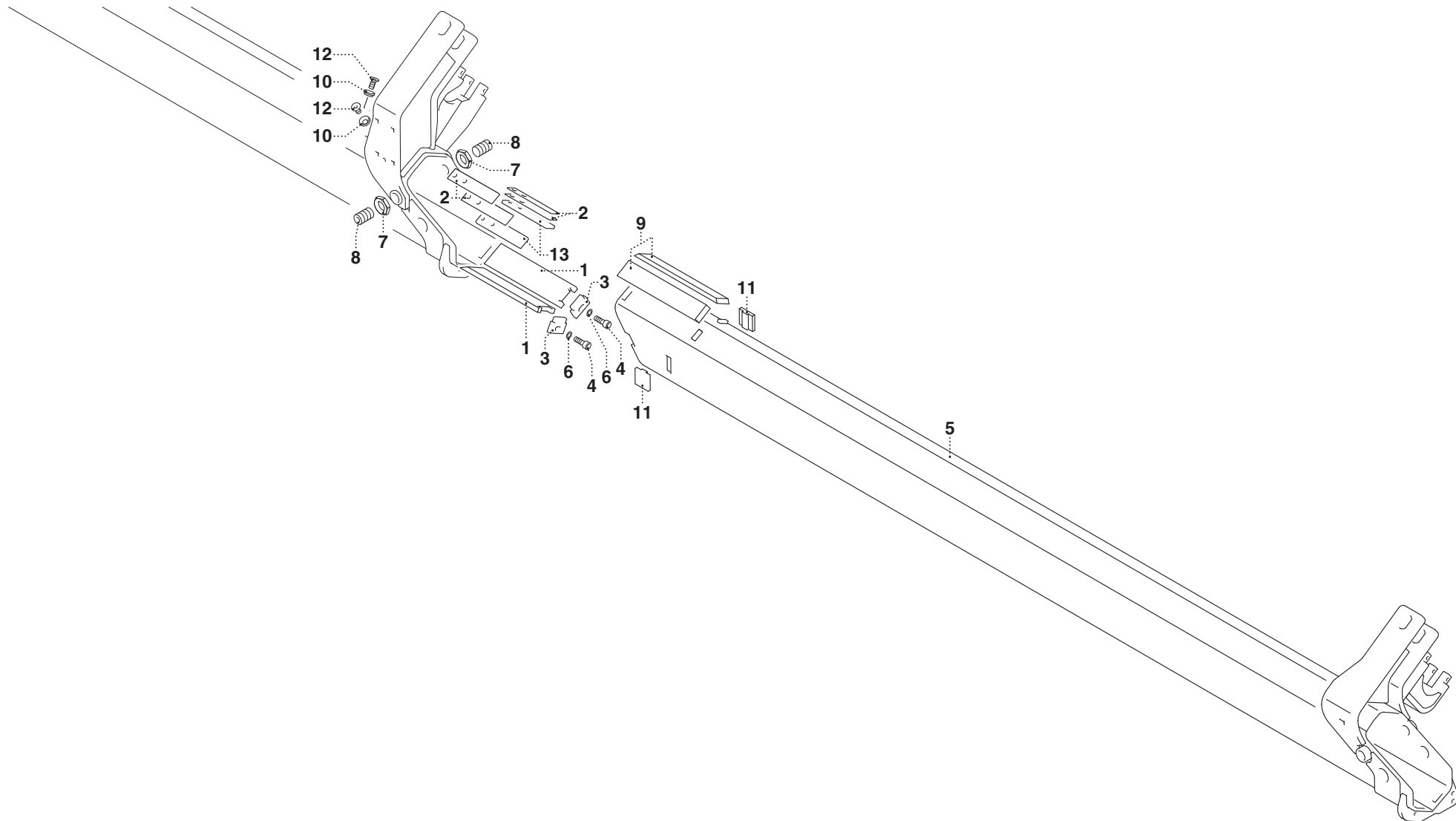

PM 21027 - PM 23027 P

matr. G107.0005

TAV. GG.08.01

POS.	N° CODICE	Q.	DESCRIZIONE	DESIGNATION	BENENNUNG	DESCRIPTION	DENOMINACIONES
1	373994	2	PATTINO	PATIN	GLEITBLOCK	SLIDING BLOCK	PATIN
2	304384	4	SPESSORE	EPAISSEUR	DICKE	THICKNESS	ESPEJOR
3	208280	2	FERMO	ARRET	VERSTELLVORRICHTUNG	LOCK	TOPE
4	497383	2	VITE	VIS	SCHRAUBE	SCREW	TORNILLO
5	142486	1	BRACCIO	BRAS	ARM	ARM	BRAZO
6	417004	2	RONDELLA	RONDELLE	SCHEIBE	WASHER	ARANDELA
7	191213	2	DADO	ECROU	MUTTER	NUT	TUERCA
8	498156	2	VITE	VIS	SCHRAUBE	SCREW	TORNILLO
9	373995	2	PATTINO	PATIN	GLEITBLOCK	SLIDING BLOCK	PATIN
10	140026	4	BORCHIA	BOSSETTE	WARZE	STUD	BULLON
11	373924	2	PATTINO	PATIN	GLEITBLOCK	SLIDING BLOCK	PATIN
12	497909	4	VITE	VIS	SCHRAUBE	SCREW	TORNILLO
13	373837	2	PATTINO	PATIN	GLEITBLOCK	SLIDING BLOCK	PATIN

PM 21026 - PM 23026 P

matr. G107.0005

TAV. GG.08.02

POS.	N° CODICE	Q.	DESCRIZIONE	DESIGNATION	BENENNUNG	DESCRIPTION	DENOMINACIONES
1	373994	2	PATTINO	PATIN	GLEITBLOCK	SLIDING BLOCK	PATIN
2	304384	4	SPESSORE	EPAISSEUR	DICKE	THICKNESS	ESPEJOR
3	208280	2	FERMO	ARRET	VERSTELLVORRICHTUNG	LOCK	TOPE
4	497383	2	VITE	VIS	SCHRAUBE	SCREW	TORNILLO
5	142492	1	BRACCIO	BRAS	ARM	ARM	BRAZO
6	417004	2	RONDELLA	RONDELLE	SCHEIBE	WASHER	ARANDELA
7	191213	2	DADO	ECROU	MUTTER	NUT	TUERCA
8	498156	2	VITE	VIS	SCHRAUBE	SCREW	TORNILLO
9	373995	2	PATTINO	PATIN	GLEITBLOCK	SLIDING BLOCK	PATIN
10	140026	4	BORCHIA	BOSSETTE	WARZE	STUD	BULLON
11	373924	2	PATTINO	PATIN	GLEITBLOCK	SLIDING BLOCK	PATIN
12	497909	4	VITE	VIS	SCHRAUBE	SCREW	TORNILLO
13	373837	2	PATTINO	PATIN	GLEITBLOCK	SLIDING BLOCK	PATIN



7° BRACCIO SFILO IDRAULICO (21027 - 23027 P)

- * 7ème bras - extension hydraulique
- * 7. Arm - hydraulische Ausziehen
- * 7th arm - hydraulic extension
- * 7mo brazo - extensión hidráulica

TAV. GG.09.01

matr. G107.0005

21
23 P

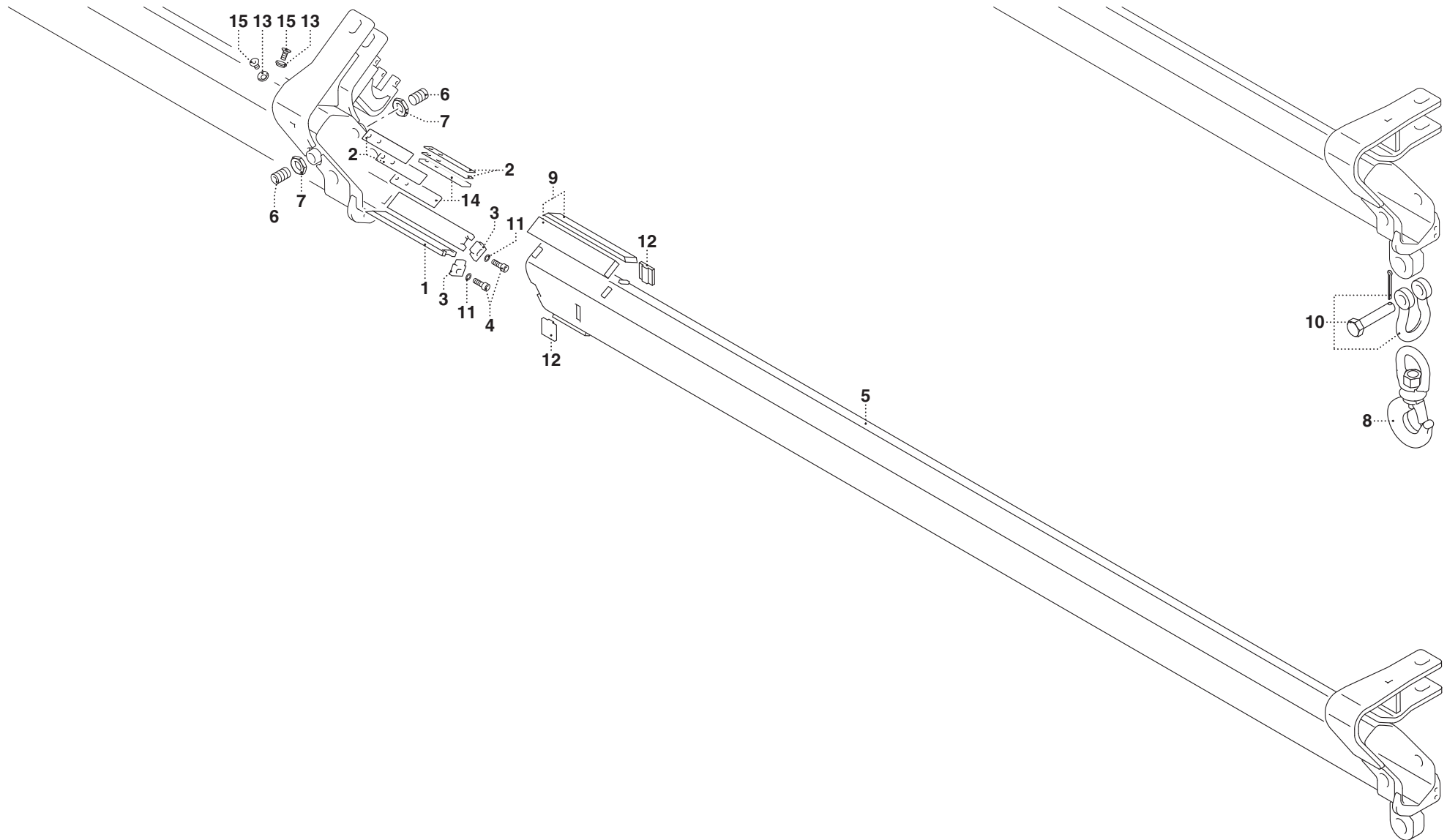

PM 21027 - PM 23027 P**matr. G107.0005****TAV. GG.09.01**

POS.	N° CODICE	Q.	DESCRIZIONE	DESIGNATION	BENENNUNG	DESCRIPTION	DENOMINACIONES
1	373996	2	PATTINO	PATIN	GLEITBLOCK	SLIDING BLOCK	PATIN
2	304384	4	SPESSORE	EPAISSEUR	DICKE	THICKNESS	ESPEJOR
3	208283	2	FERMO	ARRET	VERSTELLVORRICHTUNG	LOCK	TOPE
4	497383	2	VITE	VIS	SCHRAUBE	SCREW	TORNILLO
5	142487	1	BRACCIO	BRAS	ARM	ARM	BRAZO
6	498156	2	VITE	VIS	SCHRAUBE	SCREW	TORNILLO
7	191213	2	DADO	ECROU	MUTTER	NUT	TUERCA
8	235062	1	GANCIO	CROCHET	HAKEN	HOOK	GANCHO
9	373995	2	PATTINO	PATIN	GLEITBLOCK	SLIDING BLOCK	PATIN
10	235026	1	GRILLO	MAILLON	SCHÄCKEL	SHACKLE	GRILLETE
11	417004	2	RONDELLA	RONDELLE	SCHEIBE	WASHER	ARANDELA
12	373924	2	PATTINO	PATIN	GLEITBLOCK	SLIDING BLOCK	PATIN
13	140026	4	BORCHIA	BOSSETTE	WARZE	STUD	BULLON
14	373837	2	PATTINO	PATIN	GLEITBLOCK	SLIDING BLOCK	PATIN
15	497909	4	VITE	VIS	SCHRAUBE	SCREW	TORNILLO



MARTINETTO SFILÒ BRACCIO SECONDARIO - 340505 (LC)

- * Vérin extension bras secondaire (LC)
- * Nebenarm - Ausziehzylinder (LC)
- * Secondary arm - extension cylinder (LC)
- * Cilindro extensión brazo secundario (LC)

TAV. GH.01.01

matr. G107.0005

21
23 P

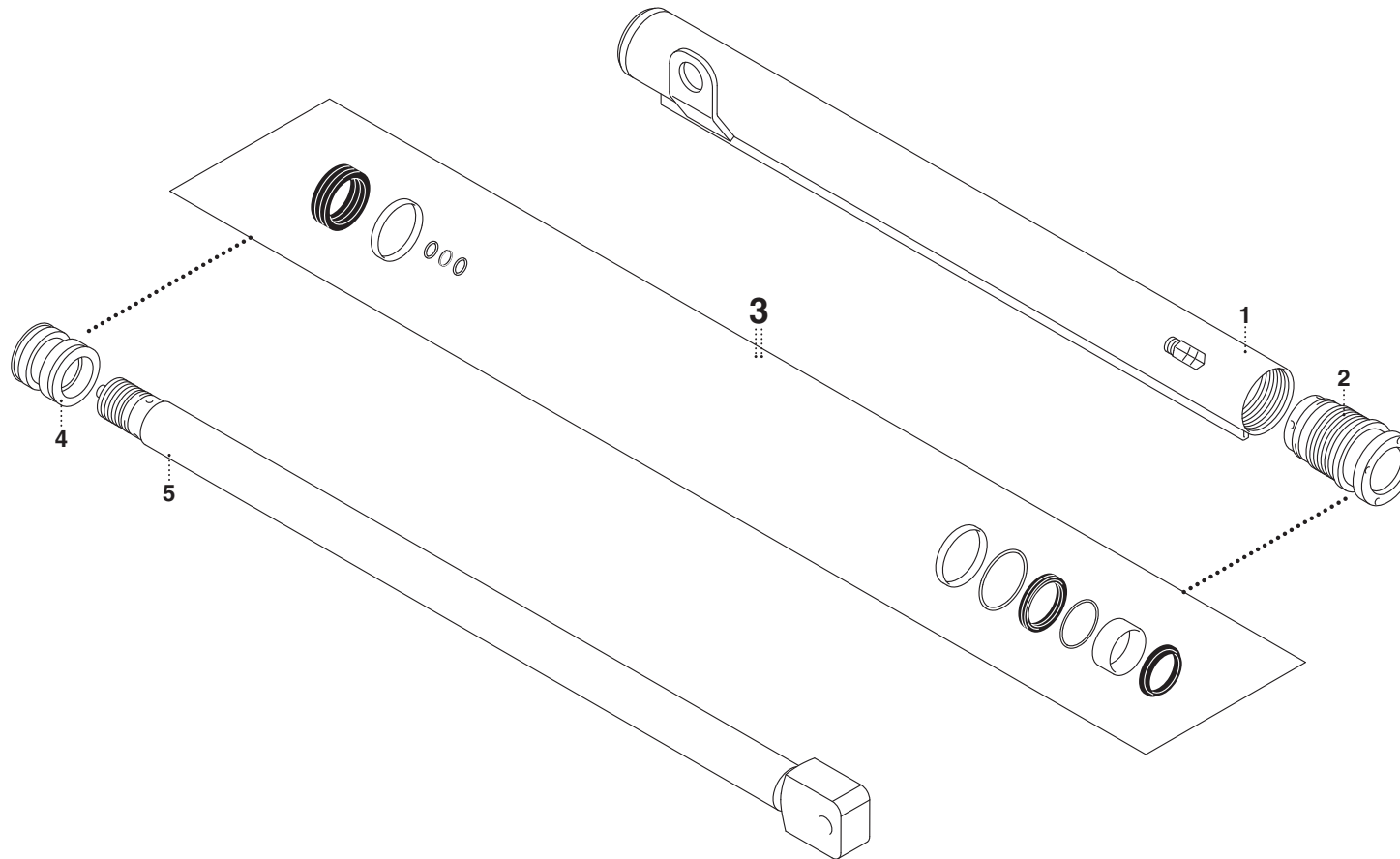

PM 21 LC - PM 23 P LC

matr. G107.0005

TAV. GH.01.01

POS.	N° CODICE	Q.	DESCRIZIONE	DESIGNATION	BENENNUNG	DESCRIPTION	DENOMINACIONES
1	161865	1	CILINDRO	CYLINDRE	ZYLINDER	CYLINDER	CILINDRO
2	479349	1	TESTATA	TETE	KOPF	HEAD	CABEZA
3	289268	1	KIT GUARNIZIONI	KIT JOINTS	DICHTUNGSSATZ	SEALS KIT	KIT JUNTAS
4	382383	1	PISTONE	PISTON	KOLBEN	PISTON	PISTON
5	121855	1	ASTA	TIGE	STANGE	ROD	VARILLA



MARTINETTO SFILÒ BRACCIO SECONDARIO - 340548 (LC)

- * Vérin extension bras secondaire (LC)
- * Nebenarm - Ausziehzylinder (LC)
- * Secondary arm - extension cylinder (LC)
- * Cilindro extensión brazo secundario (LC)

TAV. GH.01.01A

matr. G107.0069

21
23 P

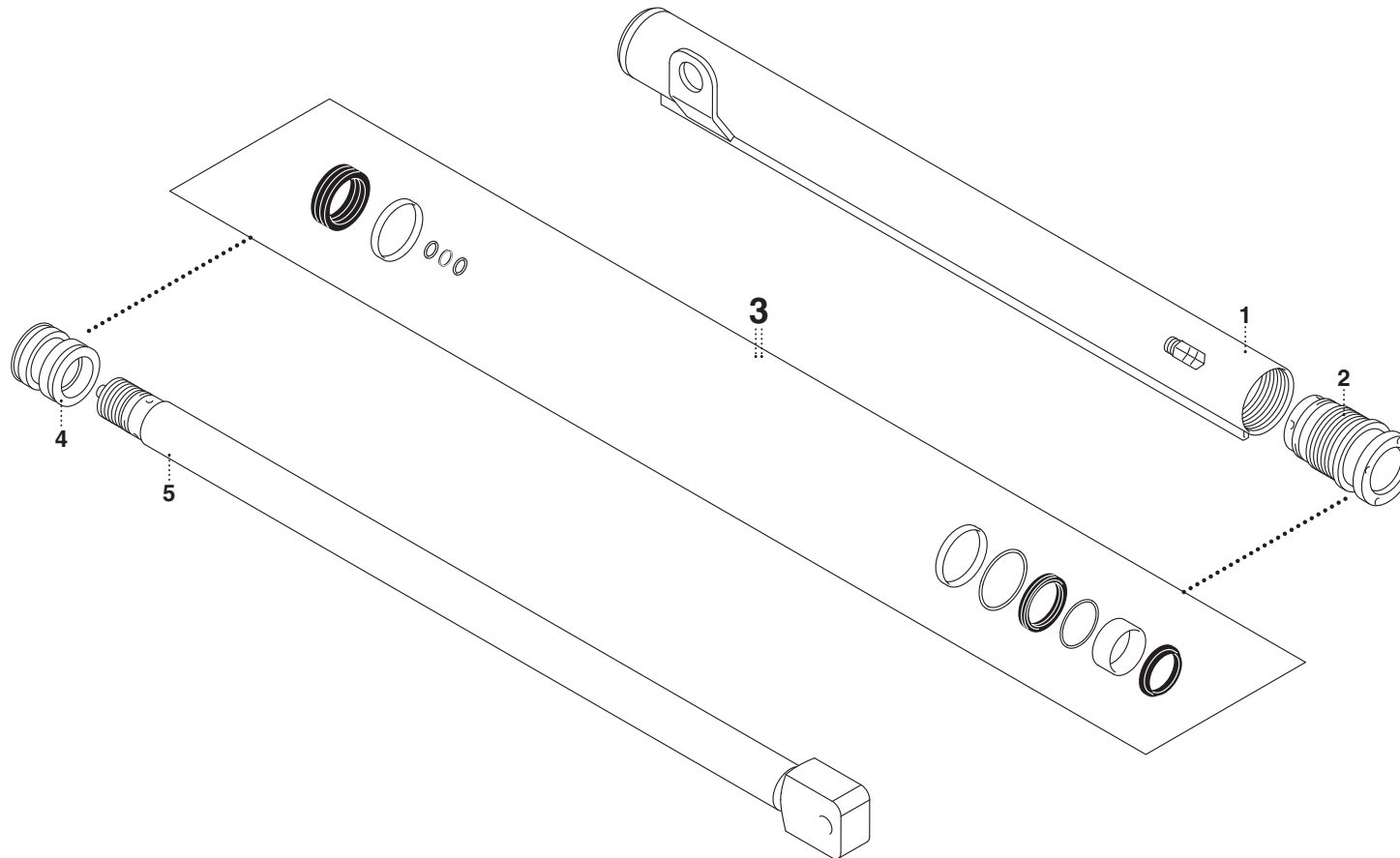

PM 21 LC - PM 23 P LC

matr. G107.0069

TAV. GH.01.01A

POS.	N° CODICE	Q.	DESCRIZIONE	DESIGNATION	BENENNUNG	DESCRIPTION	DENOMINACIONES
1	161887	1	CILINDRO	CYLINDRE	ZYLINDER	CYLINDER	CILINDRO
2	479349	1	TESTATA	TETE	KOPF	HEAD	CABEZA
3	289268	1	KIT GUARNIZIONI	KIT JOINTS	DICHTUNGSSATZ	SEALS KIT	KIT JUNTAS
4	382383	1	PISTONE	PISTON	KOLBEN	PISTON	PISTON
5	121888	1	ASTA	TIGE	STANGE	ROD	VARILLA



MARTINETTO SFILLO 1° BRACCIO IDRAULICO - 340412

- * Vérin extension - 1er bras hydraulique
- * 1. Hydraulikarm - Ausziehenzylinder
- * Extension cylinder - 1st hydraulic arm
- * Cilindro extensión - 1er brazo hidráulico

TAV. GH.02.01

matr. G107.0005

21
23 P

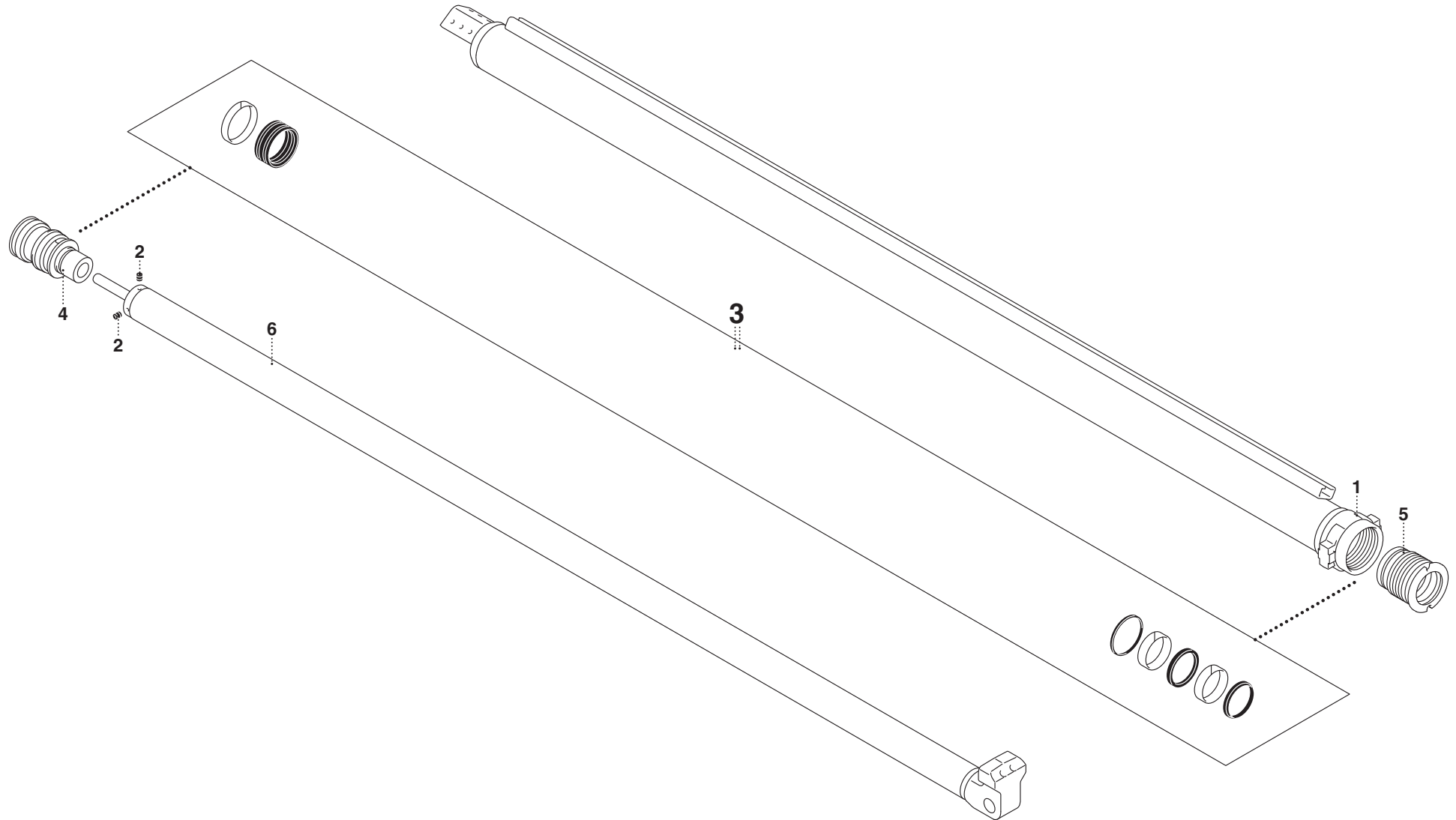

PM 21 - PM 23 P

matr. G107.0005

TAV. GH.02.01

POS.	N° CODICE	Q.	DESCRIZIONE	DESIGNATION	BENENNUNG	DESCRIPTION	DENOMINACIONES
1	161855	1	CILINDRO	CYLINDRE	ZYLINDER	CYLINDER	CILINDRO
2	497170	2	VITE	VIS	SCHRAUBE	SCREW	TORNILLO
3	230004	1	KIT GUARNIZIONI	KIT JOINTS	DICHTUNGSSATZ	SEALS KIT	KIT JUNTAS
4	382463	1	PISTONE	PISTON	KOLBEN	PISTON	PISTON
5	479430	1	TESTATA	TETE	KOPF	HEAD	CABEZA
6	121811	1	ASTA	TIGE	STANGE	ROD	VARILLA



MARTINETTO SFILO 1° BRACCIO IDRAULICO - 340549 (LC)

- * Vérin extension - 1er bras hydraulique (LC)
- * 1. Hydraulikarm - Ausziehenzylinder (LC)
- * Extension cylinder - 1st hydraulic arm (LC)
- * Cilindro extensión - 1er brazo hidráulico (LC)

TAV. GH.02.02

matr. G107.0005

21
23 P

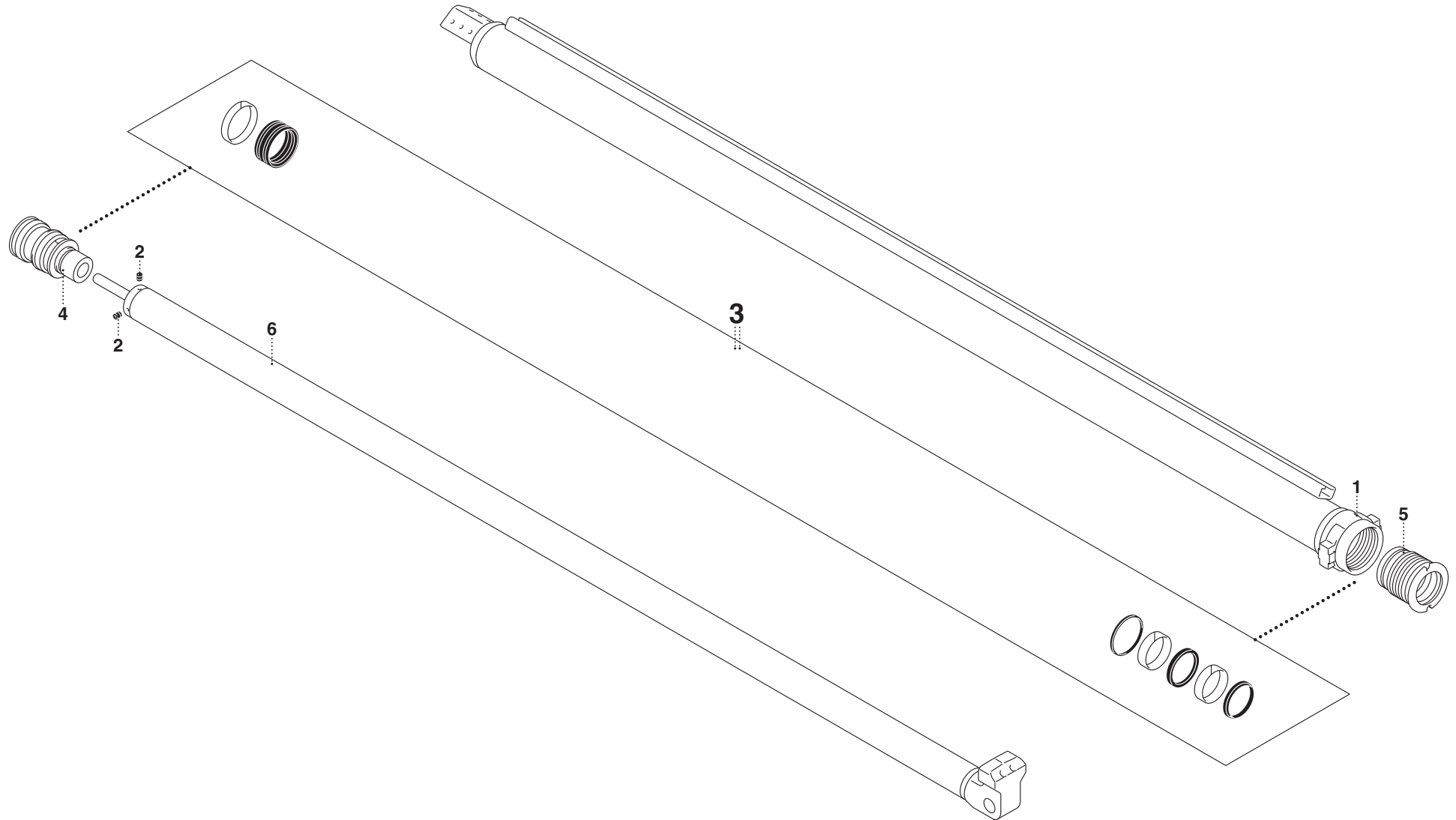

PM 21 LC - PM 23 P LC

matr. G107.0005

TAV. GH.02.02

POS.	N° CODICE	Q.	DESCRIZIONE	DESIGNATION	BENENNUNG	DESCRIPTION	DENOMINACIONES
1	161874	1	CILINDRO	CYLINDRE	ZYLINDER	CYLINDER	CILINDRO
2	497170	2	VITE	VIS	SCHRAUBE	SCREW	TORNILLO
3	230004	1	KIT GUARNIZIONI	KIT JOINTS	DICHTUNGSSATZ	SEALS KIT	KIT JUNTAS
4	382463	1	PISTONE	PISTON	KOLBEN	PISTON	PISTON
5	479430	1	TESTATA	TETE	KOPF	HEAD	CABEZA
6	121811	1	ASTA	TIGE	STANGE	ROD	VARILLA



MARTINETTO SFILÒ 2° BRACCIO IDRAULICO - 340413

- * Vérin extension - 2ème bras hydraulique
- * 2. Hydraulikarm - Ausziehenzylinder
- * Extension cylinder - 2nd hydraulic arm
- * Cilindro extensión - 2do brazo hidráulico

TAV. GH.03.01

matr. G107.0005

21
23 P

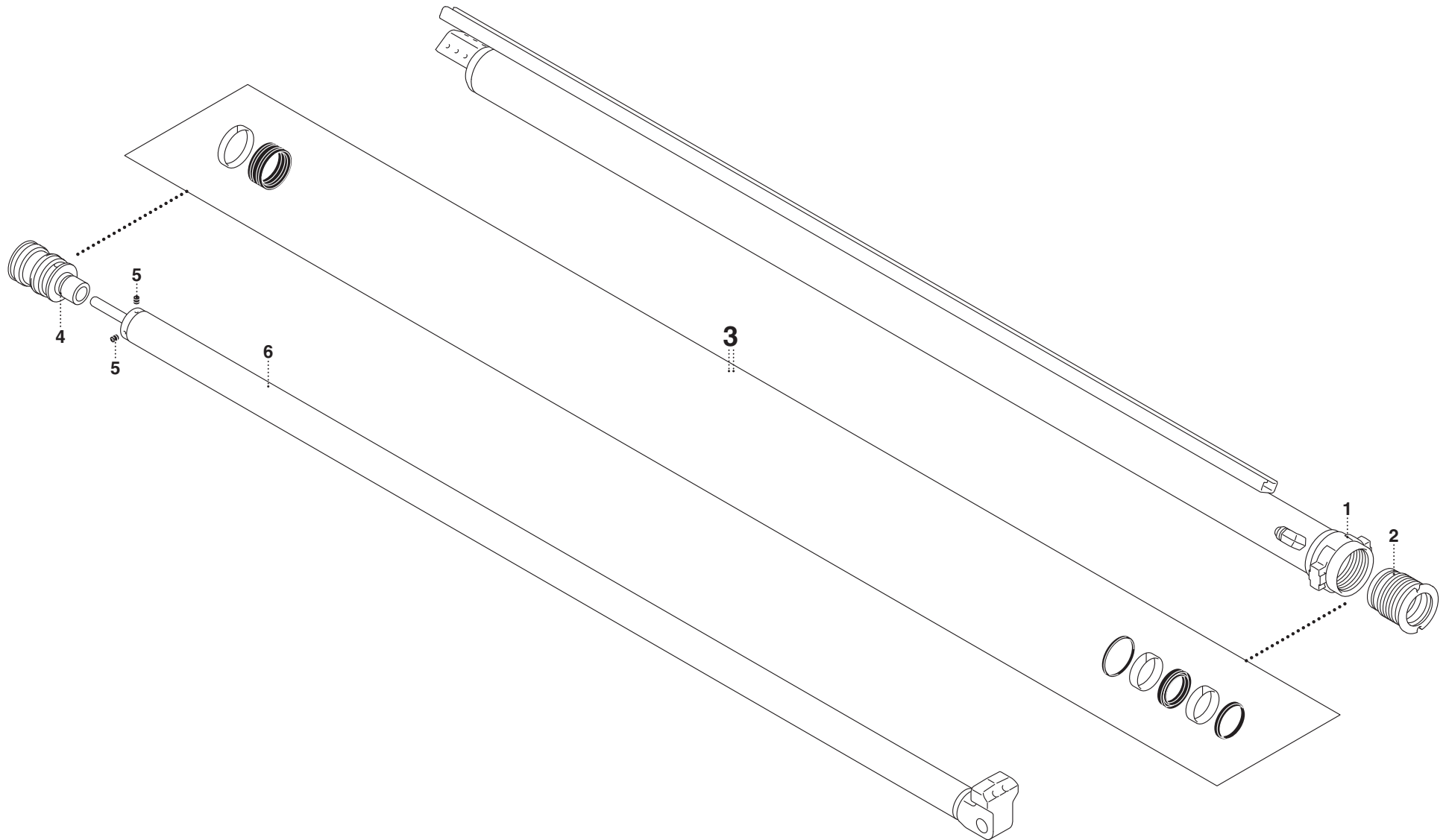



MARTINETTO SFILO 3° BRACCIO IDRAULICO - 340414

- * Vérin extension - 3ème bras hydraulique
- * 3. Hydraulikarm - Ausziehenzylinder
- * Extension cylinder - 3rd hydraulic arm
- * Cilindro extensión - 3ro brazo hidráulico

TAV. GH.04.01

matr. G107.0005

21
23 P

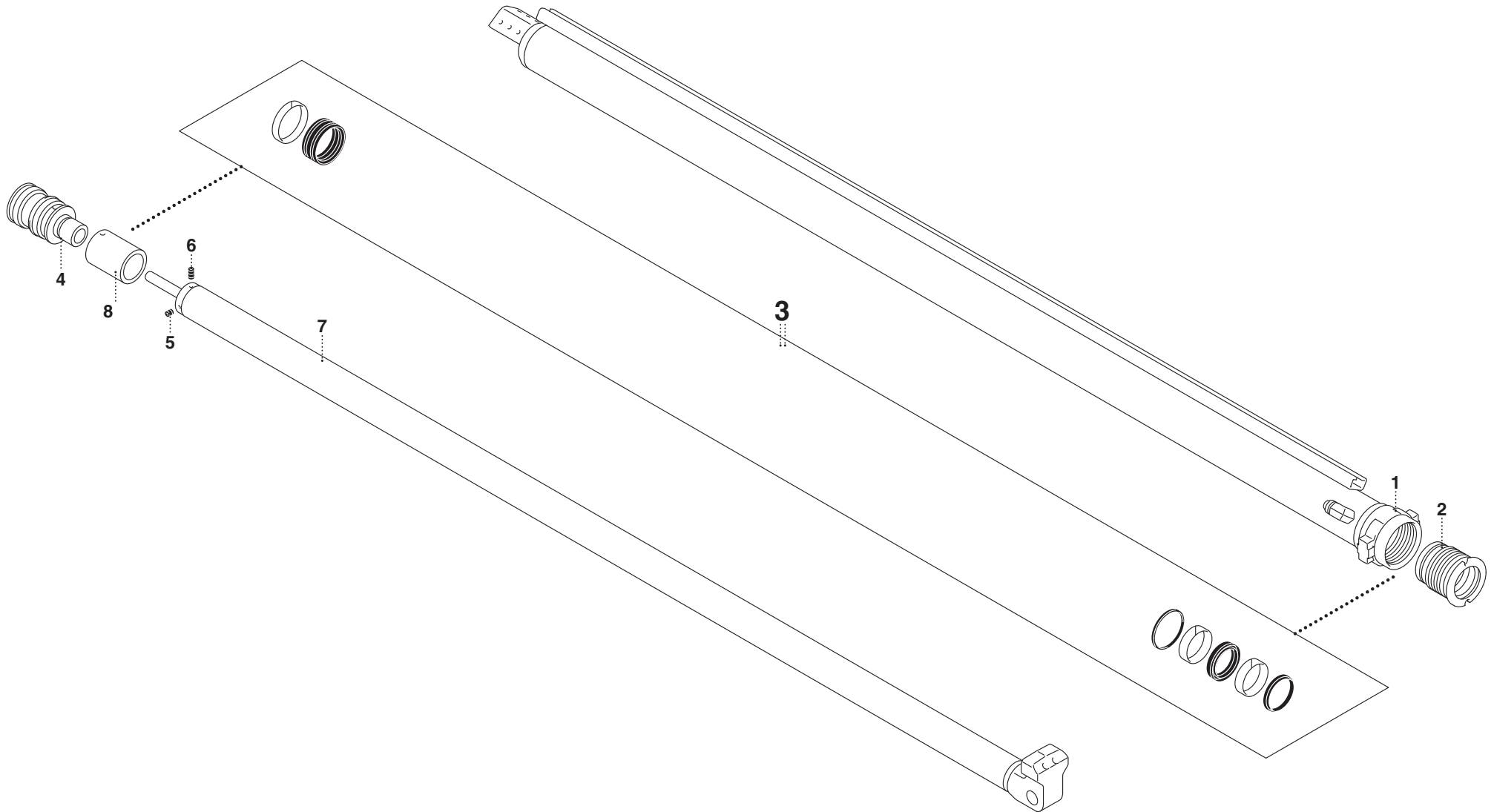

PM 21 - PM 23 P

matr. G107.0005

TAV. GH.04.01

POS.	N° CODICE	Q.	DESCRIZIONE	DESIGNATION	BENENNUNG	DESCRIPTION	DENOMINACIONES
1	161840	1	CILINDRO	CYLINDRE	ZYLINDER	CYLINDER	CILINDRO
2	479432	1	TESTATA	TETE	KOPF	HEAD	CABEZA
3	230006	1	KIT GUARNIZIONI	KIT JOINTS	DICHTUNGSSATZ	SEALS KIT	KIT JUNTAS
4	382465	1	PISTONE	PISTON	KOLBEN	PISTON	PISTON
5	497170	1	VITE	VIS	SCHRAUBE	SCREW	TORNILLO
6	497288	1	VITE	VIS	SCHRAUBE	SCREW	TORNILLO
7	121812	1	ASTA	TIGE	STANGE	ROD	VARILLA
8	136933	1	DISTANZIALE	ENTRETOISE	DISTANZSTÜCK	SPACER	DISTANCIADOR

PM 21 - PM 23 P

matr. G107.0005

TAV. GH.05.01

POS.	N° CODICE	Q.	DESCRIZIONE	DESIGNATION	BENENNUNG	DESCRIPTION	DENOMINACIONES
1	161840	1	CILINDRO	CYLINDRE	ZYLINDER	CYLINDER	CILINDRO
2	479432	1	TESTATA	TETE	KOPF	HEAD	CABEZA
3	230006	1	KIT GUARNIZIONI	KIT JOINTS	DICHTUNGSSATZ	SEALS KIT	KIT JUNTAS
4	382465	1	PISTONE	PISTON	KOLBEN	PISTON	PISTON
5	497170	2	VITE	VIS	SCHRAUBE	SCREW	TORNILLO
6	121812	1	ASTA	TIGE	STANGE	ROD	VARILLA



MARTINETTO SFILO 5° BRACCIO IDRAULICO - 340416

- * Vérin extension - 5ème bras hydraulique
- * 5. Hydraulikarm - Ausziehenzylinder
- * Extension cylinder - 5th hydraulic arm
- * Cilindro extensión - 5to brazo hidráulico

TAV. GH.06.01

matr. G107.0005

21
23 P

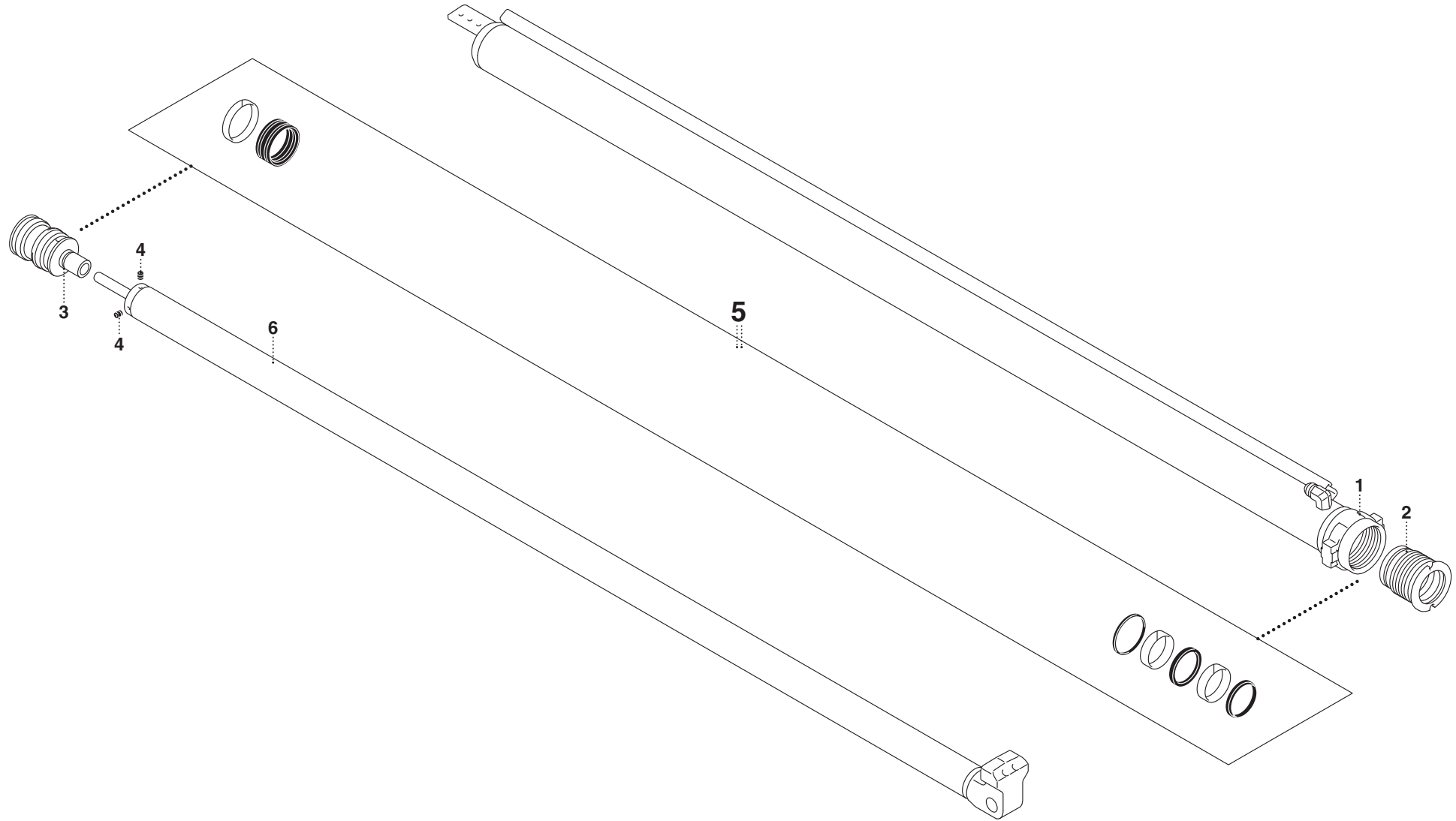

PM 21 - PM 23 P

matr. G107.0005

TAV. GH.06.01

POS.	N° CODICE	Q.	DESCRIZIONE	DESIGNATION	BENENNUNG	DESCRIPTION	DENOMINACIONES
1	161842	1	CILINDRO	CYLINDRE	ZYLINDER	CYLINDER	CILINDRO
2	479433	1	TESTATA	TETE	KOPF	HEAD	CABEZA
3	382466	1	PISTONE	PISTON	KOLBEN	PISTON	PISTON
4	497170	2	VITE	VIS	SCHRAUBE	SCREW	TORNILLO
5	230007	1	KIT GUARNIZIONI	KIT JOINTS	DICHTUNGSSATZ	SEALS KIT	KIT JUNTAS
6	121814	1	ASTA	TIGE	STANGE	ROD	VARILLA



MARTINETTO SFILO 6° BRACCIO IDRAULICO - 340416

- * Vérin extension - 6ème bras hydraulique
- * 6. Hydraulikarm - Ausziehenzylinder
- * Extension cylinder - 6th hydraulic arm
- * Cilindro extensión - 6to brazo hidráulico

TAV. GH.07.01

matr. G107.0005

21
23 P

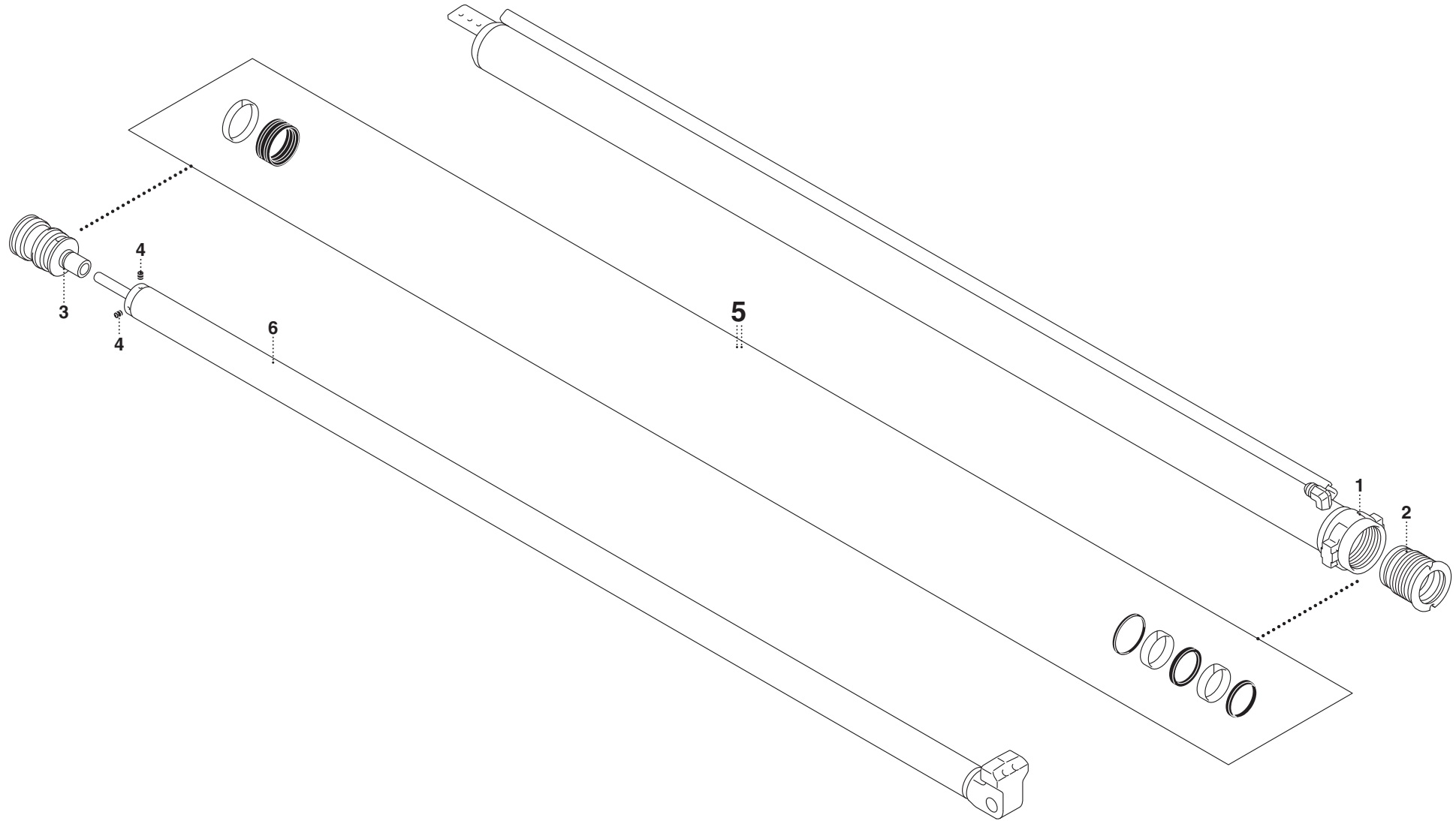

PM 21 - PM 23 P

matr. G107.0005

TAV. GH.07.01

POS.	N° CODICE	Q.	DESCRIZIONE	DESIGNATION	BENENNUNG	DESCRIPTION	DENOMINACIONES
1	161842	1	CILINDRO	CYLINDRE	ZYLINDER	CYLINDER	CILINDRO
2	479433	1	TESTATA	TETE	KOPF	HEAD	CABEZA
3	382466	1	PISTONE	PISTON	KOLBEN	PISTON	PISTON
4	497170	2	VITE	VIS	SCHRAUBE	SCREW	TORNILLO
5	230007	1	KIT GUARNIZIONI	KIT JOINTS	DICHTUNGSSATZ	SEALS KIT	KIT JUNTAS
6	121814	1	ASTA	TIGE	STANGE	ROD	VARILLA



MARTINETTO SFILO 7° BRACCIO IDRAULICO - 340417

* Vérin extension - 7ème bras hydraulique

* 7. Hydraulikarm - Ausziehenzylinder

* Extension cylinder - 7th hydraulic arm

* Cilindro extensión - 7mo brazo hidráulico

TAV. GH.08.01

matr. G107.0005

21
23 P

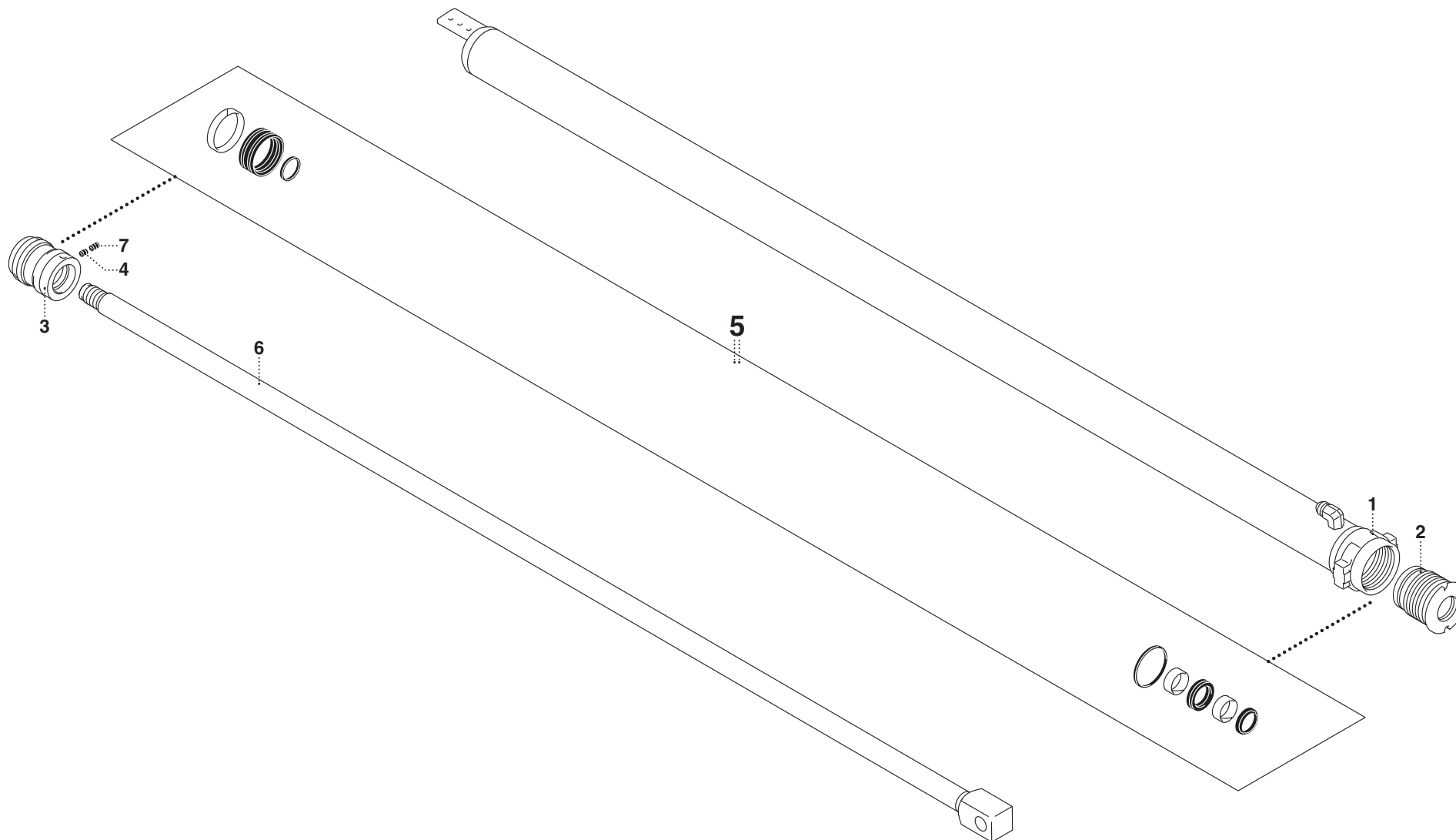

PM 21 - PM 23 P

matr. G107.0005

TAV. GH.08.01

POS.	N° CODICE	Q.	DESCRIZIONE	DESIGNATION	BENENNUNG	DESCRIPTION	DENOMINACIONES
1	161843	1	CILINDRO	CYLINDRE	ZYLINDER	CYLINDER	CILINDRO
2	479434	1	TESTATA	TETE	KOPF	HEAD	CABEZA
3	382467	1	PISTONE	PISTON	KOLBEN	PISTON	PISTON
4	497170	2	VITE	VIS	SCHRAUBE	SCREW	TORNILLO
5	230008	1	KIT GUARNIZIONI	KIT JOINTS	DICHTUNGSSATZ	SEALS KIT	KIT JUNTAS
6	121815	1	ASTA	TIGE	STANGE	ROD	VARILLA
7	497356	2	VITE	VIS	SCHRAUBE	SCREW	TORNILLO



DOPPIO COMANDO - HYDROCONTROL - MANUALE (21)

* Double commande - HYDROCONTROL - manuel
* Zweiseitige Steuerung - HYDROCONTROL - manuelle
* Dual side control - HYDROCONTROL - manual
* Mando bilateral - HYDROCONTROL - manual

TAV. GI.01.01

matr. G107.0005

21
23 P

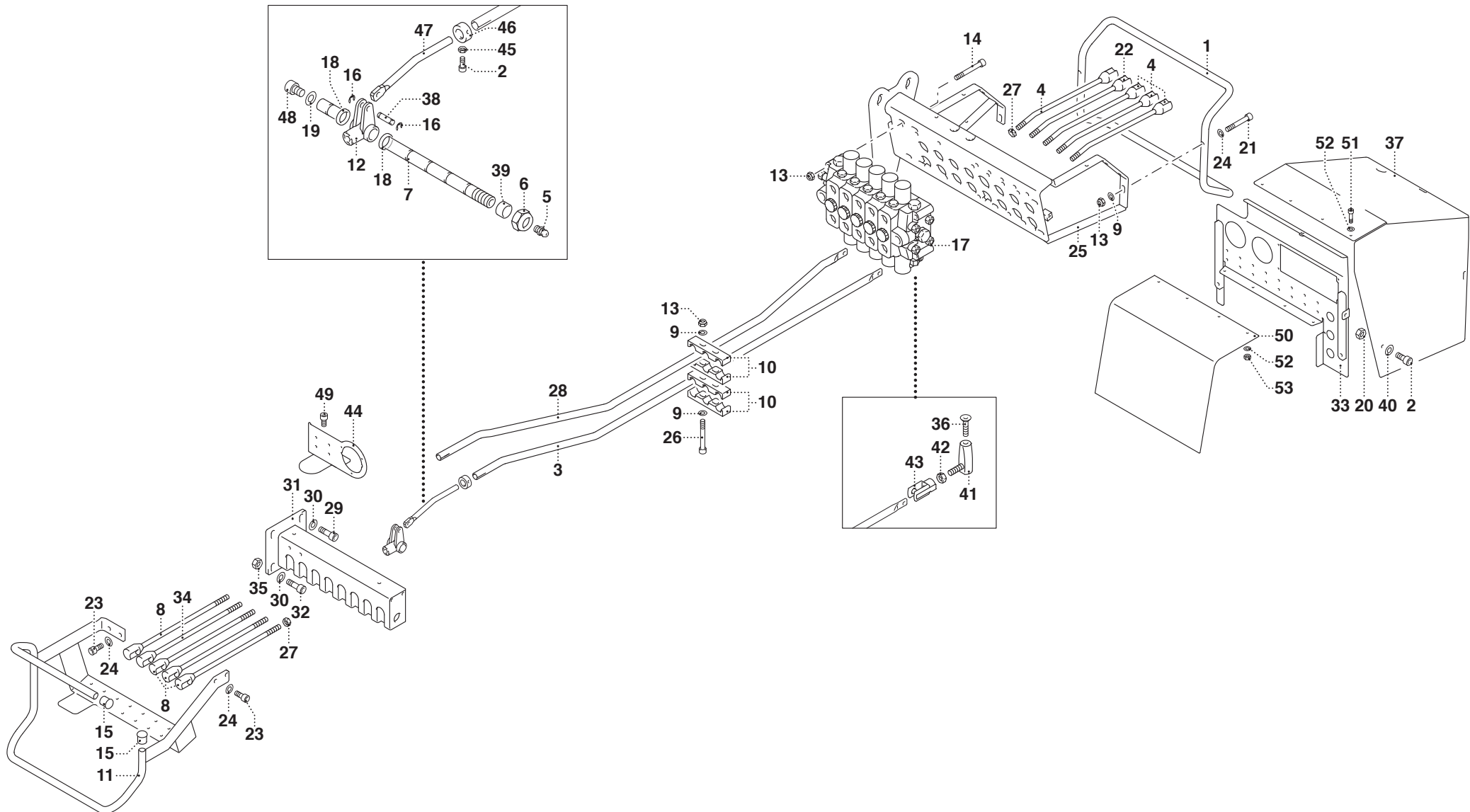

PM 21

matr. G107.0005

TAV. GI.01.01

POS.	N° CODICE	Q.	DESCRIZIONE	DESIGNATION	BENENNUNG	DESCRIPTION	DENOMINACIONES
1	403084	1	PROTEZIONE	PROTECTION	SCHUTZ	GUARD	PROTECCION
2	497118	9	VITE	VIS	SCHRAUBE	SCREW	TORNILLO
3	481265	3	TIRANTE	TIRANT	ZUGSTANGE	TIE ROD	TIRANTE
4	120031	4	LEVA	LEVIER	HEBEL	LEVER	PALANCA
5	281005	1	INGRASSATORE	GRAISSEUR	SCHMIERER	GREASE FITTING	ENGRASADOR
6	191121	1	DADO	ECROU	MUTTER	NUT	TUERCA
7	379776	1	PERNO	AXE	BOLZEN	PIN	PERNO
8	120570	4	LEVA	LEVIER	HEBEL	LEVER	PALANCA
9	417004	12	RONDELLA	RONDELLE	SCHEIBE	WASHER	ARANDELA
10	353068	2	MORSETTO	ETAU	KLEMME	CLAMP	PRENSOR
11	403273	1	PROTEZIONE	PROTECTION	SCHUTZ	GUARD	PROTECCION
12	131013	7	BIELLA	BIELLE	PLEUELSTANGE	LINKBAR	BIELA
13	191168	5	DADO	ECROU	MUTTER	NUT	TUERCA
14	498038	4	VITE	VIS	SCHRAUBE	SCREW	TORNILLO
15	385004	2	TAPPO	BOUCHON	VERSCHLUSSDECKEL	PLUG	TAPON
16	109159	14	ANELLO	BAGUE	RING	RING	ANILLO
17	197665	1	DISTRIBUTORE - 5 ELEMENTI	DISTRIBUTEUR - 5 ELEM.	STEUERVENTIL - 5 ELEM.	CONTROL VALVE B. - 5 ELEM.	DISTRIBUIDOR - 5 ELEM.
17	197667	1	DISTRIBUTORE - 6 ELEMENTI	DISTRIBUTEUR - 6 ELEM.	STEUERVENTIL - 6 ELEM.	CONTROL VALVE B. - 6 ELEM.	DISTRIBUIDOR - 6 ELEM.
17	197668	1	DISTRIBUTORE - 7 ELEMENTI	DISTRIBUTEUR - 7 ELEM.	STEUERVENTIL - 7 ELEM.	CONTROL VALVE B. - 7 ELEM.	DISTRIBUIDOR - 7 ELEM.
17	197666	1	DISTRIBUTORE - 6 ELEMENTI - ARGANO	DISTRIBUTEUR - 6 ELEM. - TREUIL	STEUERVENTIL - 6 ELEM. - WINDE	CONTROL VALVE B. - 6 ELEM. - WINCH	DISTRIB. - 6 ELEM. - CABRESTANTE
18	136127	7	DISTANZIALE	ENTRETOISE	DISTANZSTÜCK	SPACER	DISTANCIADOR
19	417027	1	RONDELLA	RONDELLE	SCHEIBE	WASHER	ARANDELA
20	191125	4	DADO	ECROU	MUTTER	NUT	TUERCA
21	497134	2	VITE	VIS	SCHRAUBE	SCREW	TORNILLO
22	120033	1	LEVA	LEVIER	HEBEL	LEVER	PALANCA
23	497130	6	VITE	VIS	SCHRAUBE	SCREW	TORNILLO



DOPPIO COMANDO - HYDROCONTROL - MANUALE (21)

* Double commande - HYDROCONTROL - manuel
* Zweiseitige Steuerung - HYDROCONTROL - manuelle
* Dual side control - HYDROCONTROL - manual
* Mando bilateral - HYDROCONTROL - manual

TAV. GI.01.01

matr. G107.0005

21
23 P

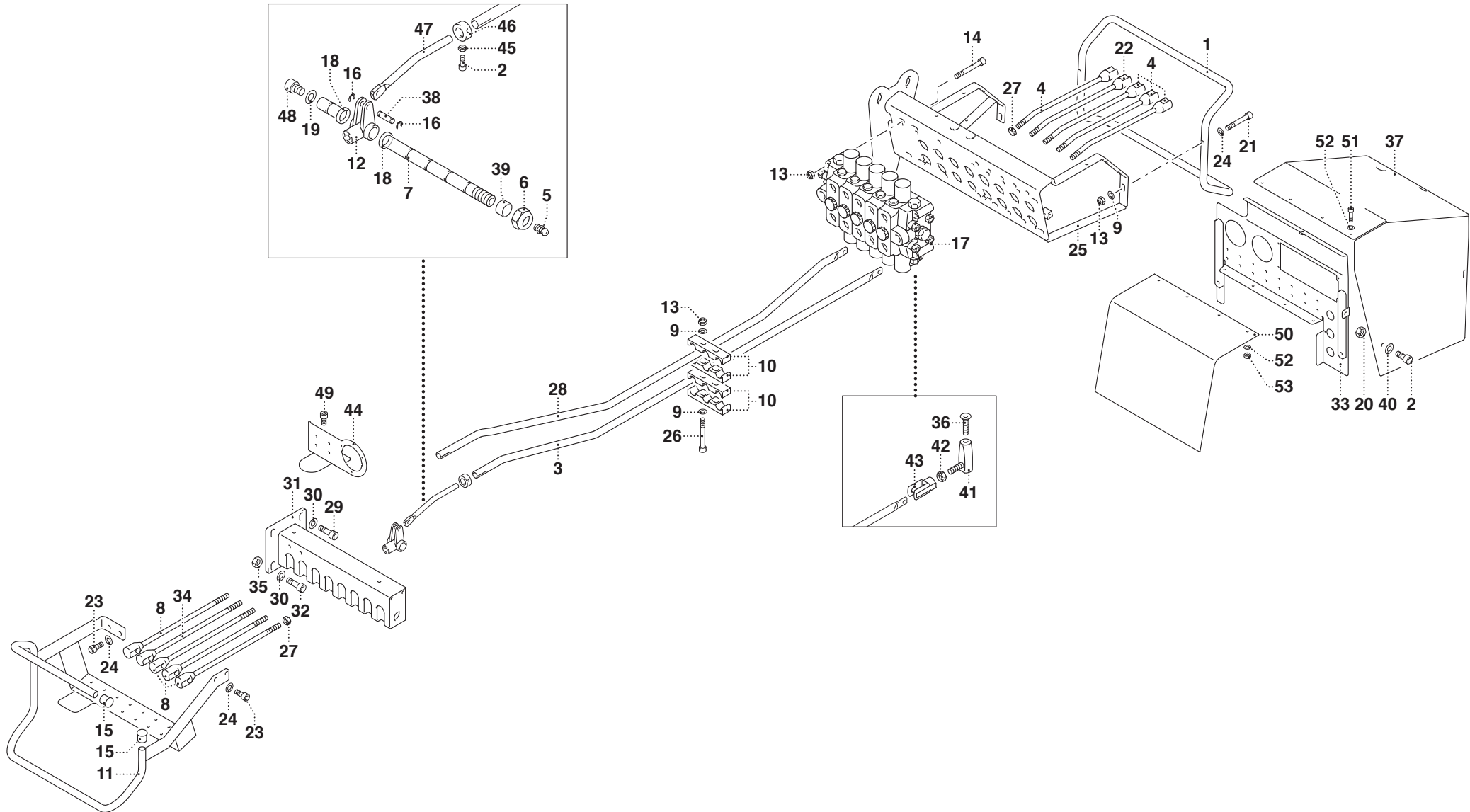

PM 21

matr. G107.0005

TAV. GI.01.01

POS.	N° CODICE	Q.	DESCRIZIONE	DESIGNATION	BENENNUNG	DESCRIPTION	DENOMINACIONES
24	417025	11	RONDELLA	RONDELLE	SCHEIBE	WASHER	ARANDELA
25	467598	1	SUPPORTO	SUPPORT	TRÄGER	SUPPORT	SOPORTE
26	497141	2	VITE	VIS	SCHRAUBE	SCREW	TORNILLO
27	191064	10	DADO	ECROU	MUTTER	NUT	TUERCA
28	481266	2	TIRANTE	TIRANT	ZUGSTANGE	TIE ROD	TIRANTE
29	497145	2	VITE	VIS	SCHRAUBE	SCREW	TORNILLO
30	417026	8	RONDELLA	RONDELLE	SCHEIBE	WASHER	ARANDELA
31	466343	1	SUPPORTO	SUPPORT	TRÄGER	SUPPORT	SOPORTE
32	497147	2	VITE	VIS	SCHRAUBE	SCREW	TORNILLO
33	176439	1	CARTER	CARTER	GEHÄUSE	CASING	CARTER
34	120568	1	LEVA	LEVIER	HEBEL	LEVER	PALANCA
35	191045	2	DADO	ECROU	MUTTER	NUT	TUERCA
36	498099	5	VITE	VIS	SCHRAUBE	SCREW	TORNILLO
37	176440	1	CARTER	CARTER	GEHÄUSE	CASING	CARTER
38	379322	7	PERNO	AXE	BOLZEN	PIN	PERNO
39	136089	1	DISTANZIALE	ENTRETOISE	DISTANZSTÜCK	SPACER	DISTANCIADOR
40	417024	4	RONDELLA	RONDELLE	SCHEIBE	WASHER	ARANDELA
41	379727	5	PERNO	AXE	BOLZEN	PIN	PERNO
42	191063	5	DADO	ECROU	MUTTER	NUT	TUERCA
43	220018	5	FORCELLA	FOURCHE	GABEL	CLEVIS	HORQUILLA
44	467613	1	SUPPORTO	SUPPORT	TRÄGER	SUPPORT	SOPORTE
45	191062	5	DADO	ECROU	MUTTER	NUT	TUERCA
46	112167	5	BOCCOLA	DOUILLE	BUCHSE	BUSHING	CASQUILLO
47	283015	5	TIRANTE	TIRANT	ZUGSTANGE	TIE ROD	TIRANTE
48	497159	1	VITE	VIS	SCHRAUBE	SCREW	TORNILLO
49	497129	2	VITE	VIS	SCHRAUBE	SCREW	TORNILLO



DOPPIO COMANDO - HYDROCONTROL - MANUALE (21)

* Double commande - HYDROCONTROL - manuel
* Zweiseitige Steuerung - HYDROCONTROL - manuelle
* Dual side control - HYDROCONTROL - manual
* Mando bilateral - HYDROCONTROL - manual

TAV. GI.01.01

matr. G107.0005

21
23 P

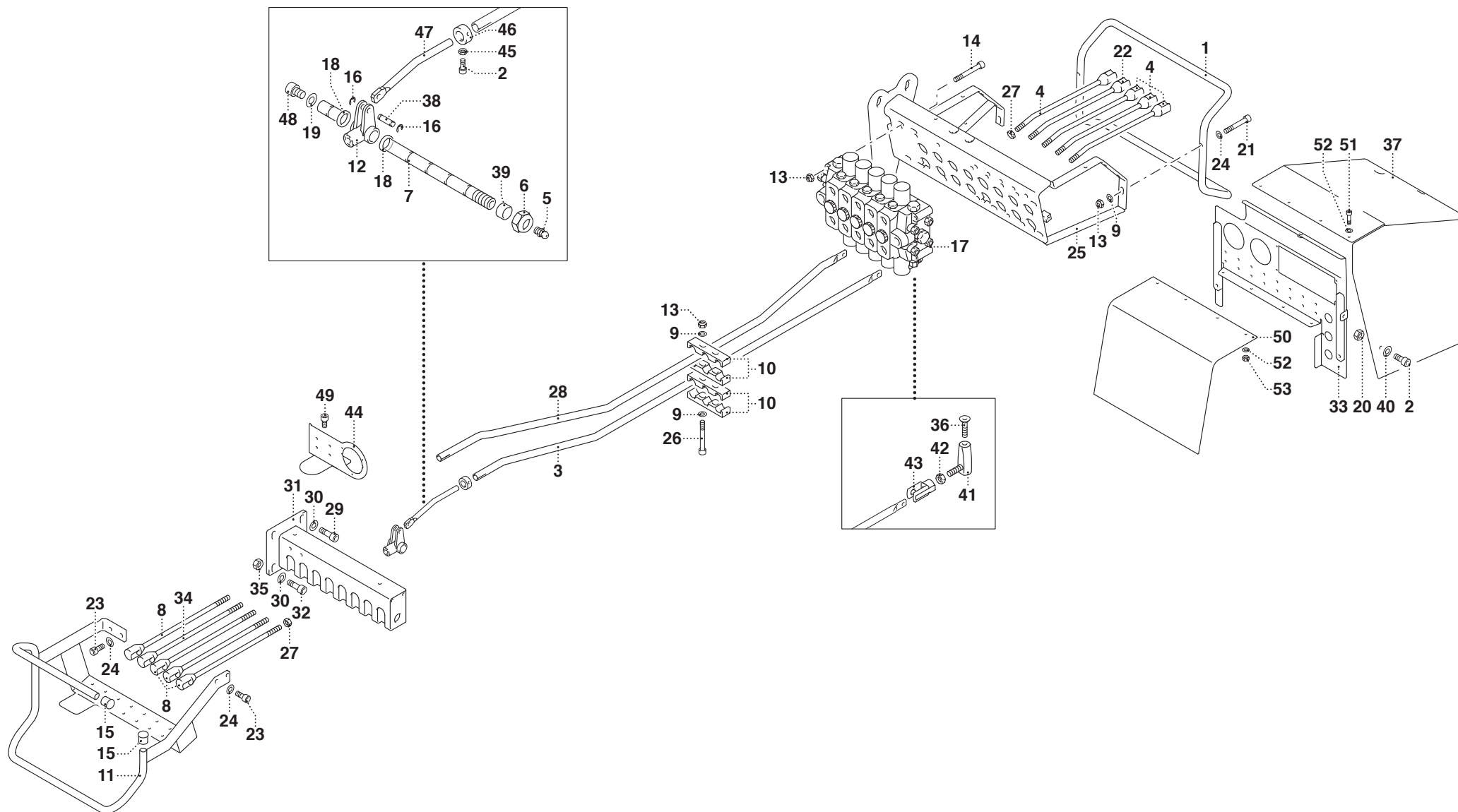

PM 21

matr. G107.0005

TAV. GI.01.02

POS.	N° CODICE	Q.	DESCRIZIONE	DESIGNATION	BENENNUNG	DESCRIPTION	DENOMINACIONES
1	403084	1	PROTEZIONE	PROTECTION	SCHUTZ	GUARD	PROTECCION
2	417024	4	RONDELLA	RONDELLE	SCHEIBE	WASHER	ARANDELA
3	497118	5	VITE	VIS	SCHRAUBE	SCREW	TORNILLO
4	176440	1	CARTER	CARTER	GEHÄUSE	CASING	CARTER
5	176439	1	COPERCHIO	COUVERCLE	DECKEL	COVER	TAPA
6	498099	1	VITE	VIS	SCHRAUBE	SCREW	TORNILLO
7	379727	1	PERNO	AXE	BOLZEN	PIN	PERNO
8	191063	1	DADO	ECROU	MUTTER	NUT	TUERCA
9	417004	2	RONDELLA	RONDELLE	SCHEIBE	WASHER	ARANDELA
10	220018	1	FORCELLA	FOURCHE	GABEL	CLEVIS	HORQUILLA
11	353068	2	MORSETTO	ETAU	KLEMME	CLAMP	PRENSOR
12	417004	2	RONDELLA	RONDELLE	SCHEIBE	WASHER	ARANDELA
13	191168	7	DADO	ECROU	MUTTER	NUT	TUERCA
14	120031	4	LEVA	LEVIER	HEBEL	LEVER	PALANCA
15	197647	1	DISTRIBUTORE - 5 ELEMENTI - 12 V	DISTRIBUTEUR - 5 ELEM. - 12 V	STEUERVENTIL - 5 ELEM. - 12 V	CONTROL VALVE B. - 5 ELEM. - 12 V	DISTRIBUIDOR - 5 ELEM. - 12 V
15	197649	1	DISTRIBUTORE - 6 ELEMENTI - 12 V	DISTRIBUTEUR - 6 ELEM. - 12 V	STEUERVENTIL - 6 ELEM. - 12 V	CONTROL VALVE B. - 6 ELEM. - 12 V	DISTRIBUIDOR - 6 ELEM. - 12 V
15	197651	1	DISTRIBUTORE - 7 ELEMENTI - 12 V	DISTRIBUTEUR - 7 ELEM. - 12 V	STEUERVENTIL - 7 ELEM. - 12 V	CONTROL VALVE B. - 7 ELEM. - 12 V	DISTRIBUIDOR - 7 ELEM. - 12 V
15	197648	1	DISTRIBUTORE - 6 ELEMENTI - ARGANO (12 V)	DISTRIBUTEUR - 6 EL. - TREUIL (12 V)	STEUERVENTIL - 6 EL. - WINDE (12 V)	CONTROL VALVE B. - 6 EL. - WINCH (12 V)	DISTRIBUIDOR - 6 EL. - CABR. (12 V)
15	197653	1	DISTRIBUTORE - 5 ELEMENTI - 24 V	DISTRIBUTEUR - 5 ELEM. - 24 V	STEUERVENTIL - 5 ELEM. - 24 V	CONTROL VALVE B. - 5 ELEM. - 24 V	DISTRIBUIDOR - 5 ELEM. - 24 V
15	197655	1	DISTRIBUTORE - 6 ELEMENTI - 24 V	DISTRIBUTEUR - 6 ELEM. - 24 V	STEUERVENTIL - 6 ELEM. - 24 V	CONTROL VALVE B. - 6 ELEM. - 24 V	DISTRIBUIDOR - 6 ELEM. - 24 V
15	197657	1	DISTRIBUTORE - 7 ELEMENTI - 24 V	DISTRIBUTEUR - 7 ELEM. - 24 V	STEUERVENTIL - 7 ELEM. - 24 V	CONTROL VALVE B. - 7 ELEM. - 24 V	DISTRIBUIDOR - 7 ELEM. - 24 V
15	197654	1	DISTRIBUTORE - 6 ELEMENTI - ARGANO (24 V)	DISTRIBUTEUR - 6 EL. - TREUIL (24 V)	STEUERVENTIL - 6 EL. - WINDE (24 V)	CONTROL VALVE B. - 6 EL. - WINCH (24 V)	DISTRIBUIDOR - 6 EL. - CABR. (24 V)
16	120570	1	LEVA	LEVIER	HEBEL	LEVER	PALANCA
17	191064	6	DADO	ECROU	MUTTER	NUT	TUERCA
18	191121	1	DADO	ECROU	MUTTER	NUT	TUERCA
19	191125	10	DADO	ECROU	MUTTER	NUT	TUERCA



DOPPIO COMANDO - HYDROCONTROL - RADIOCOMANDO (21)

* Double commande - Hydrocontrol - Radiocommande
* Zweiseitige Steuerung - Hydrocontrol - Fernsteuerung
* Dual side control - Hydrocontrol - Radio control
* Mando bilaterale - Hydrocontrol - Radiomando

TAV. GI.01.02

matr. G107.0005

21
23 P

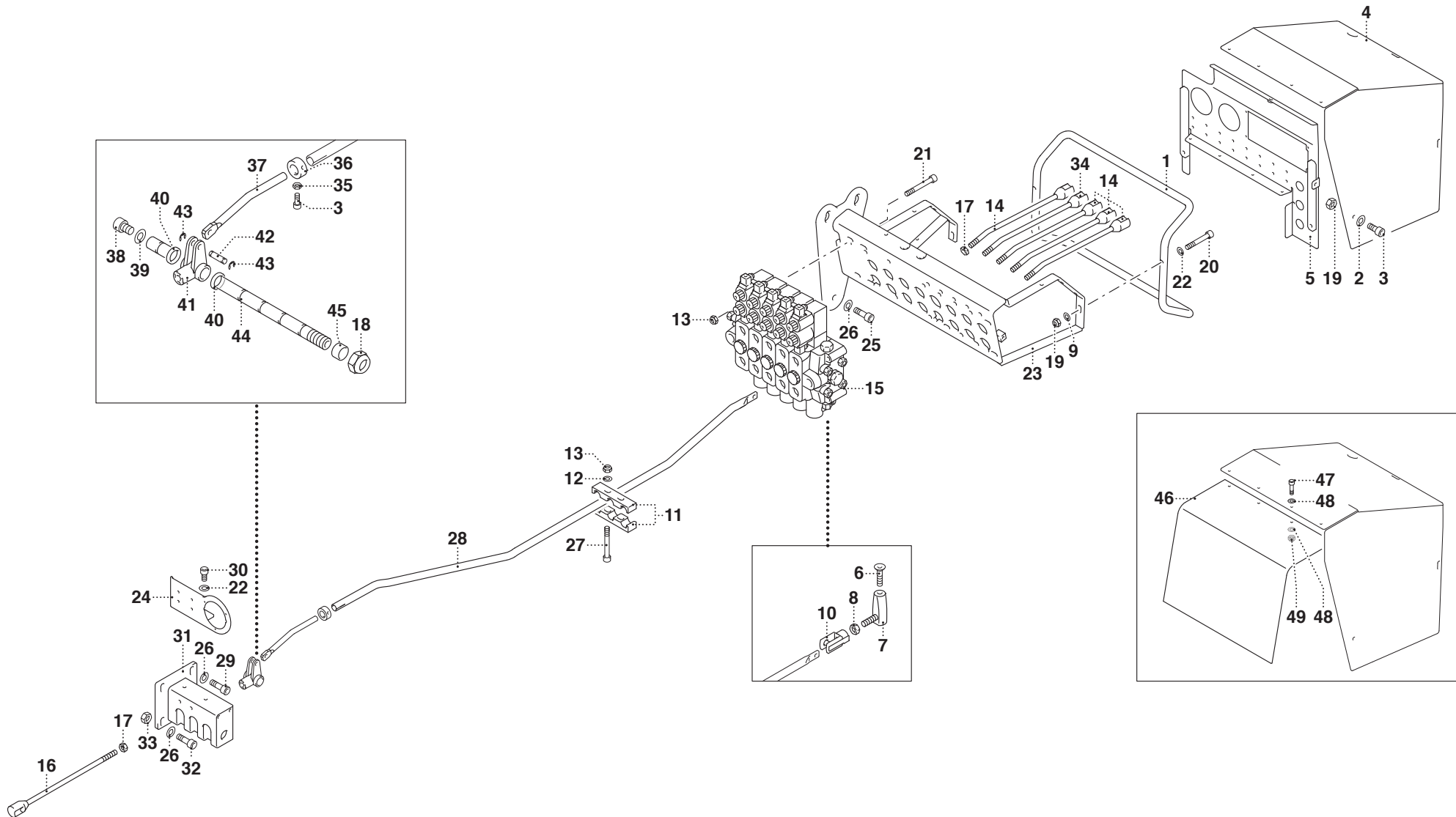

PM 21

matr. G107.0005

TAV. GI.01.02

POS.	N° CODICE	Q.	DESCRIZIONE	DESIGNATION	BENENNUNG	DESCRIPTION	DENOMINACIONES
20	497134	2	VITE	VIS	SCHRAUBE	SCREW	TORNILLO
21	498038	4	VITE	VIS	SCHRAUBE	SCREW	TORNILLO
22	417025	7	RONDELLA	RONDELLE	SCHEIBE	WASHER	ARANDELA
23	467598	1	SUPPORTO	SUPPORT	TRÄGER	SUPPORT	SOPORTE
24	467613	1	SUPPORTO	SUPPORT	TRÄGER	SUPPORT	SOPORTE
25	497381	1	VITE	VIS	SCHRAUBE	SCREW	TORNILLO
26	417026	5	RONDELLA	RONDELLE	SCHEIBE	WASHER	ARANDELA
27	497136	2	VITE	VIS	SCHRAUBE	SCREW	TORNILLO
28	481266	1	TIRANTE	TIRANT	ZUGSTANGE	TIE ROD	TIRANTE
29	497142	2	VITE	VIS	SCHRAUBE	SCREW	TORNILLO
30	497129	2	VITE	VIS	SCHRAUBE	SCREW	TORNILLO
31	467614	1	SUPPORTO	SUPPORT	TRÄGER	SUPPORT	SOPORTE
32	497147	2	VITE	VIS	SCHRAUBE	SCREW	TORNILLO
33	191045	2	DADO	ECROU	MUTTER	NUT	TUERCA
34	120033	1	LEVA	LEVIER	HEBEL	LEVER	PALANCA
35	191062	1	DADO	ECROU	MUTTER	NUT	TUERCA
36	112167	1	BOCCOLA	DOUILLE	BUCHSE	BUSHING	CASQUILLO
37	283015	1	TIRANTE	TIRANT	ZUGSTANGE	TIE ROD	TIRANTE
38	497159	1	VITE	VIS	SCHRAUBE	SCREW	TORNILLO
39	417027	1	RONDELLA	RONDELLE	SCHEIBE	WASHER	ARANDELA
40	136127	3	DISTANZIALE	ENTRETOISE	DISTANZSTÜCK	SPACER	DISTANCIADOR
41	131013	2	BIELLA	BIELLE	PLEUELSTANGE	LINKBAR	BIELA
42	379322	1	PERNO	AXE	BOLZEN	PIN	PERNO
43	109159	2	ANELLO	BAGUE	RING	RING	ANILLO
44	380484	1	PERNO	AXE	BOLZEN	PIN	PERNO
45	136089	1	DISTANZIALE	ENTRETOISE	DISTANZSTÜCK	SPACER	DISTANCIADOR



DOPPIO COMANDO - HYDROCONTROL - RADIOCOMANDO (21)

* Double commande - Hydrocontrol - Radiocommande
* Zweiseitige Steuerung - Hydrocontrol - Fernsteuerung
* Dual side control - Hydrocontrol - Radio control
* Mando bilaterale - Hydrocontrol - Radiomando

TAV. GI.01.02

matr. G107.0005

21
23 P

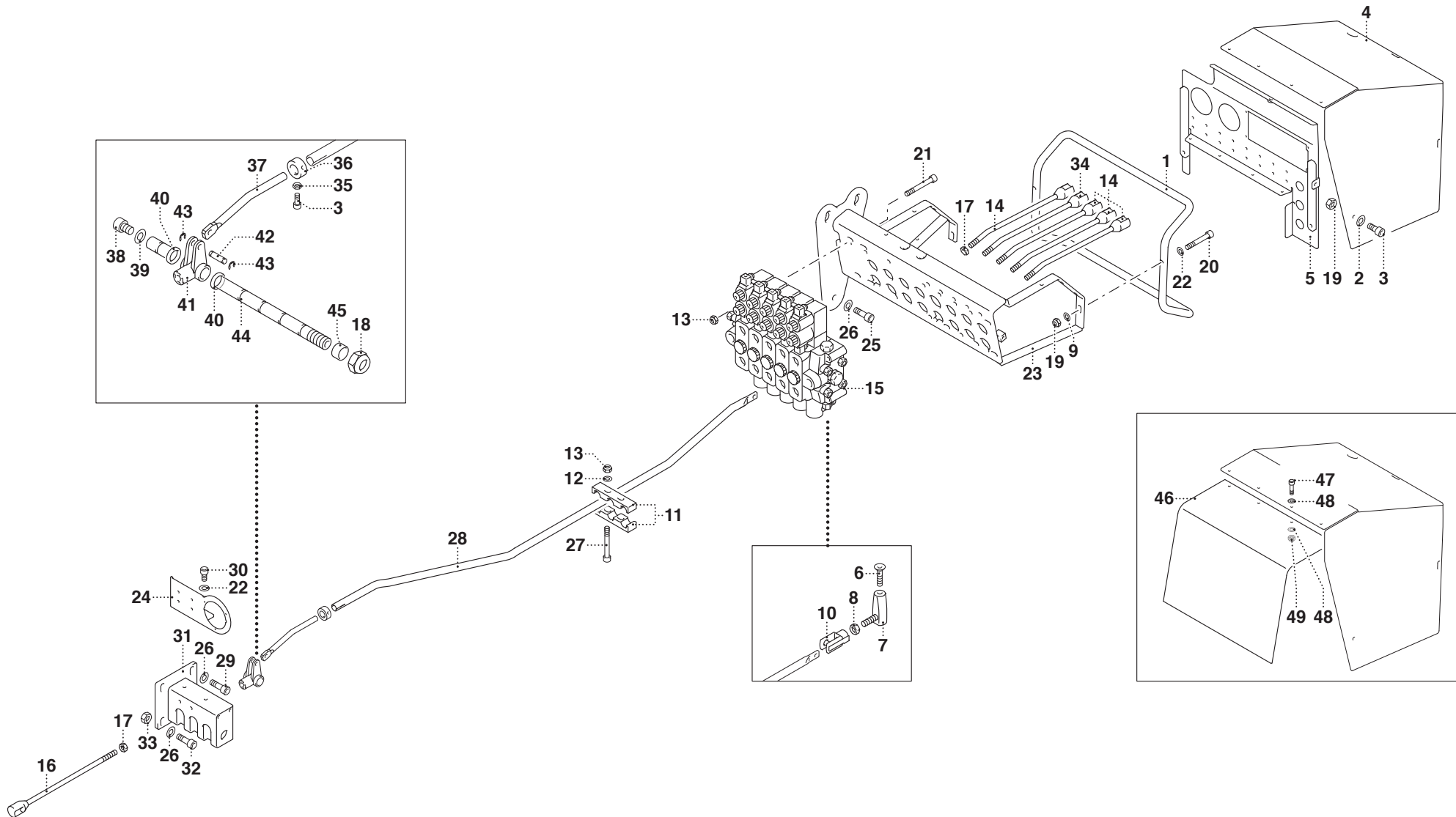

PM 21

matr. G107.0005

TAV. GI.01.03

POS.	N° CODICE	Q.	DESCRIZIONE	DESIGNATION	BENENNUNG	DESCRIPTION	DENOMINACIONES
1	403084	1	PROTEZIONE	PROTECTION	SCHUTZ	GUARD	PROTECCION
2	417024	4	RONDELLA	RONDELLE	SCHEIBE	WASHER	ARANDELA
3	497118	5	VITE	VIS	SCHRAUBE	SCREW	TORNILLO
4	176440	1	CARTER	CARTER	GEHÄUSE	CASING	CARTER
5	176439	1	COPERCHIO	COUVERCLE	DECKEL	COVER	TAPA
6	498099	1	VITE	VIS	SCHRAUBE	SCREW	TORNILLO
7	379727	1	PERNO	AXE	BOLZEN	PIN	PERNO
8	191063	1	DADO	ECROU	MUTTER	NUT	TUERCA
9	417004	2	RONDELLA	RONDELLE	SCHEIBE	WASHER	ARANDELA
10	220018	1	FORCELLA	FOURCHE	GABEL	CLEVIS	HORQUILLA
11	353068	2	MORSETTO	ETAU	KLEMME	CLAMP	PRENSOR
12	417004	2	RONDELLA	RONDELLE	SCHEIBE	WASHER	ARANDELA
13	191168	4	DADO	ECROU	MUTTER	NUT	TUERCA
14	497132	1	VITE	VIS	SCHRAUBE	SCREW	TORNILLO
15	197669	1	DISTRIBUTORE - 5 ELEMENTI (A)	DISTRIBUTEUR - 5 ELEM. (A)	STEUERVENTIL - 5 ELEM. (A)	CONTROL VALVE B. - 5 ELEM. (A)	DISTRIBUIDOR - 5 ELEM. (A)
15	197671	1	DISTRIBUTORE - 6 ELEMENTI (A)	DISTRIBUTEUR - 6 ELEM. (A)	STEUERVENTIL - 6 ELEM. (A)	CONTROL VALVE B. - 6 ELEM. (A)	DISTRIBUIDOR - 6 ELEM. (A)
15	197672	1	DISTRIBUTORE - 7 ELEMENTI (A)	DISTRIBUTEUR - 7 ELEM. (A)	STEUERVENTIL - 7 ELEM. (A)	CONTROL VALVE B. - 7 ELEM. (A)	DISTRIBUIDOR - 7 ELEM. (A)
15	197670	1	DISTRIBUTORE - 6 ELEM. - ARGANO (A)	DISTRIBUTEUR - 6 EL. - TREUIL (A)	STEUERVENTIL - 6 EL. - WINDE (A)	CONTROL VALVE B. - 6 EL. - WINCH (A)	DISTRIBUIDOR - 6 EL.-CABR. (A)
15	197673	1	DISTRIBUTORE - 5 ELEMENTI (H)	DISTRIBUTEUR - 5 ELEM. (H)	STEUERVENTIL - 5 ELEM. (H)	CONTROL VALVE B. - 5 ELEM. (H)	DISTRIBUIDOR - 5 ELEM. (H)
15	197675	1	DISTRIBUTORE - 6 ELEMENTI (H)	DISTRIBUTEUR - 6 ELEM. (H)	STEUERVENTIL - 6 ELEM. (H)	CONTROL VALVE B. - 6 ELEM. (H)	DISTRIBUIDOR - 6 ELEM. (H)
15	197676	1	DISTRIBUTORE - 7 ELEMENTI (H)	DISTRIBUTEUR - 7 ELEM. (H)	STEUERVENTIL - 7 ELEM. (H)	CONTROL VALVE B. - 7 ELEM. (H)	DISTRIBUIDOR - 7 ELEM. (H)
15	197674	1	DISTRIBUTORE - 6 ELEM. - ARGANO (H)	DISTRIBUTEUR - 6 EL. - TREUIL (H)	STEUERVENTIL - 6 EL. - WINDE (H)	CONTROL VALVE B. - 6 EL. - WINCH (H)	DISTRIBUIDOR - 6 EL.-CABR. (H)
16	123180	1	PIASTRA	PLAQUE	PLATTE	PLATE	PLACA
17	120031	1	LEVA	LEVIER	HEBEL	LEVER	PALANCA
18	120570	1	LEVA	LEVIER	HEBEL	LEVER	PALANCA
19	191125	10	DADO	ECROU	MUTTER	NUT	TUERCA



COMANDO - DANFOSS (21)

* *Commande - DANFOSS*
* *Steuerung - DANFOSS*
* *Control - DANFOSS*
* *Mando - DANFOSS*

TAV. GI.01.03

matr. G107.0005

21
23 P

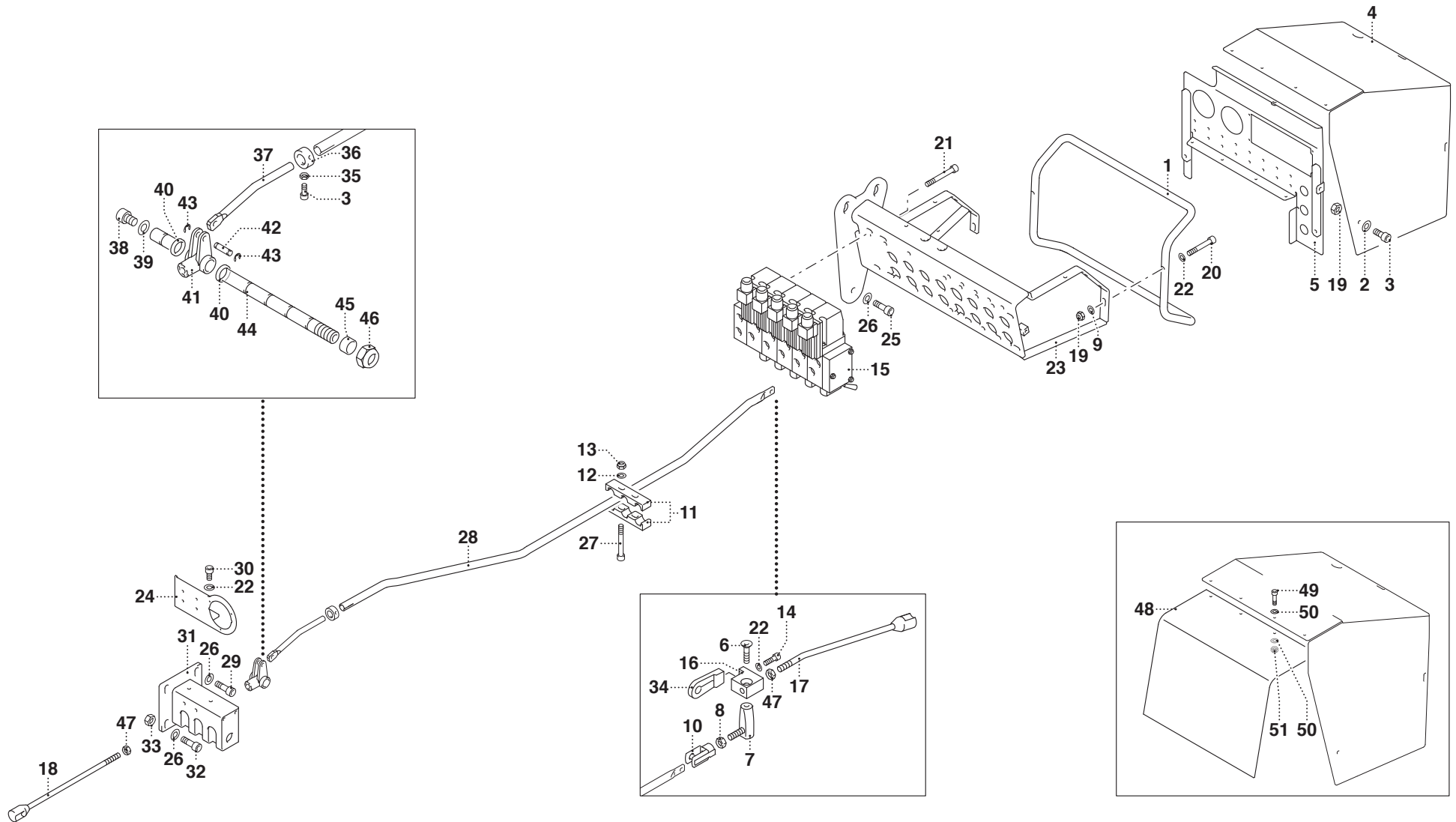

PM 21**matr. G107.0005****TAV. GI.01.03**

POS.	N° CODICE	Q.	DESCRIZIONE	DESIGNATION	BENENNUNG	DESCRIPTION	DENOMINACIONES
20	497134	2	VITE	VIS	SCHRAUBE	SCREW	TORNILLO
21	497130	4	VITE	VIS	SCHRAUBE	SCREW	TORNILLO
22	417025	7	RONDELLA	RONDELLE	SCHEIBE	WASHER	ARANDELA
23	467598	1	SUPPORTO	SUPPORT	TRÄGER	SUPPORT	SOPORTE
24	467613	1	SUPPORTO	SUPPORT	TRÄGER	SUPPORT	SOPORTE
25	497381	1	VITE	VIS	SCHRAUBE	SCREW	TORNILLO
26	417026	5	RONDELLA	RONDELLE	SCHEIBE	WASHER	ARANDELA
27	497136	2	VITE	VIS	SCHRAUBE	SCREW	TORNILLO
28	481266	1	TIRANTE	TIRANT	ZUGSTANGE	TIE ROD	TIRANTE
29	497142	2	VITE	VIS	SCHRAUBE	SCREW	TORNILLO
30	497129	2	VITE	VIS	SCHRAUBE	SCREW	TORNILLO
31	467614	1	SUPPORTO	SUPPORT	TRÄGER	SUPPORT	SOPORTE
32	497147	2	VITE	VIS	SCHRAUBE	SCREW	TORNILLO
33	191045	2	DADO	ECROU	MUTTER	NUT	TUERCA
34	164133	1	COLONNETTA	COLONNETTE	SCHRAUBBOLZEN	STUD BOLT	PERNO FILETEADO
35	191062	1	DADO	ECROU	MUTTER	NUT	TUERCA
36	112167	1	BOCCOLA	DOUILLE	BUCHSE	BUSHING	CASQUILLO
37	283015	1	TIRANTE	TIRANT	ZUGSTANGE	TIE ROD	TIRANTE
38	497159	1	VITE	VIS	SCHRAUBE	SCREW	TORNILLO
39	417027	1	RONDELLA	RONDELLE	SCHEIBE	WASHER	ARANDELA
40	136127	3	DISTANZIALE	ENTRETOISE	DISTANZSTÜCK	SPACER	DISTANCIADOR
41	131013	2	BIELLA	BIELLE	PLEUELSTANGE	LINKBAR	BIELA
42	379322	1	PERNO	AXE	BOLZEN	PIN	PERNO
43	109159	2	ANELLO	BAGUE	RING	RING	ANILLO
44	380484	1	PERNO	AXE	BOLZEN	PIN	PERNO
45	136089	1	DISTANZIALE	ENTRETOISE	DISTANZSTÜCK	SPACER	DISTANCIADOR



COMANDO - DANFOSS (21)

* *Commande - DANFOSS*
* *Steuerung - DANFOSS*
* *Control - DANFOSS*
* *Mando - DANFOSS*

TAV. GI.01.03

matr. G107.0005

21
23 P

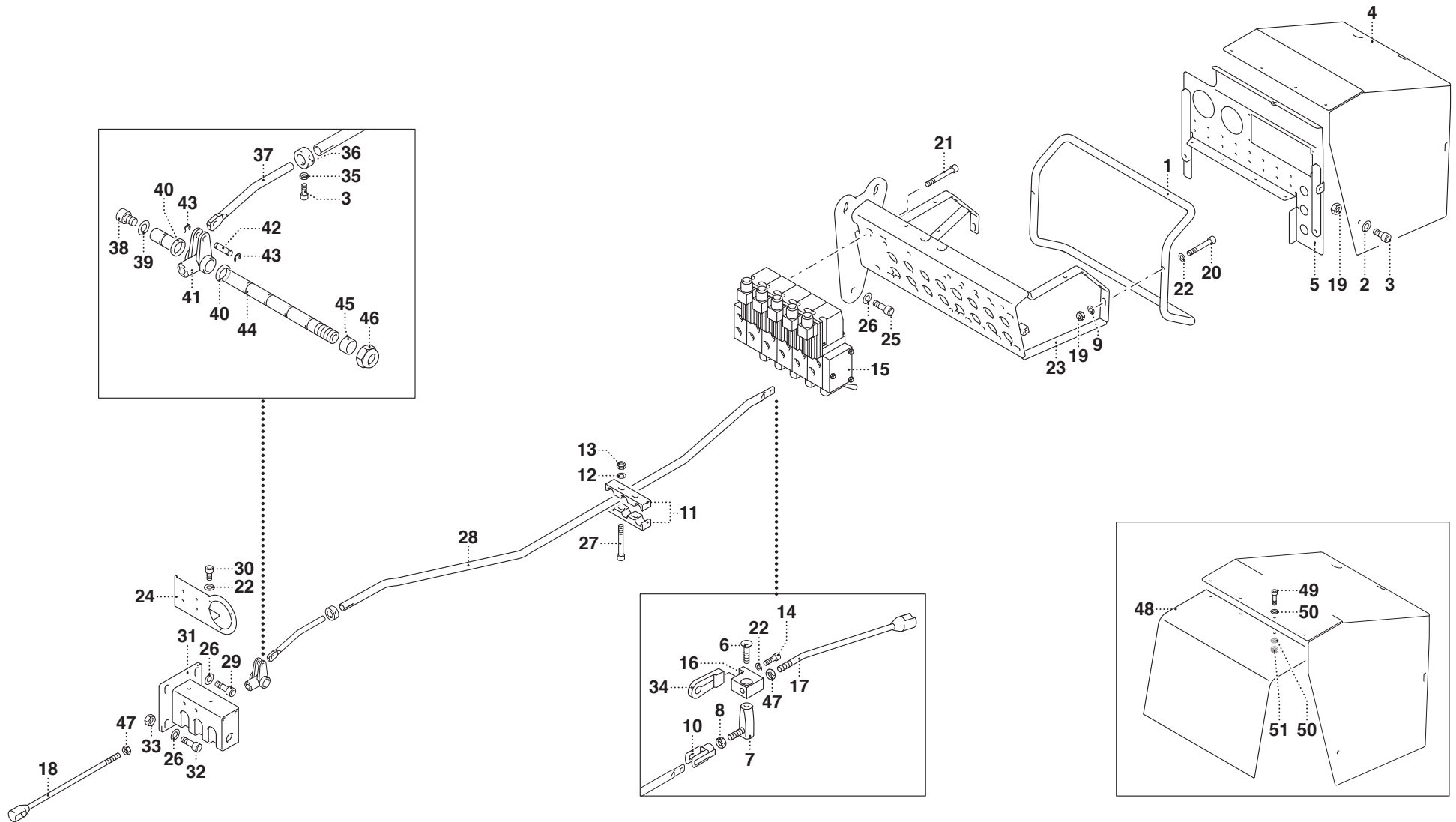



COMANDO - DANFOSS (P.T.) (23 P)

- * *Commande - DANFOSS (P.T.)*
- * *Steuerung - DANFOSS (P.T.)*
- * *Control - DANFOSS (P.T.)*
- * *Mando - DANFOSS (P.T.)*

TAV. GI.01.04

matr. G107.0005

21
23 P

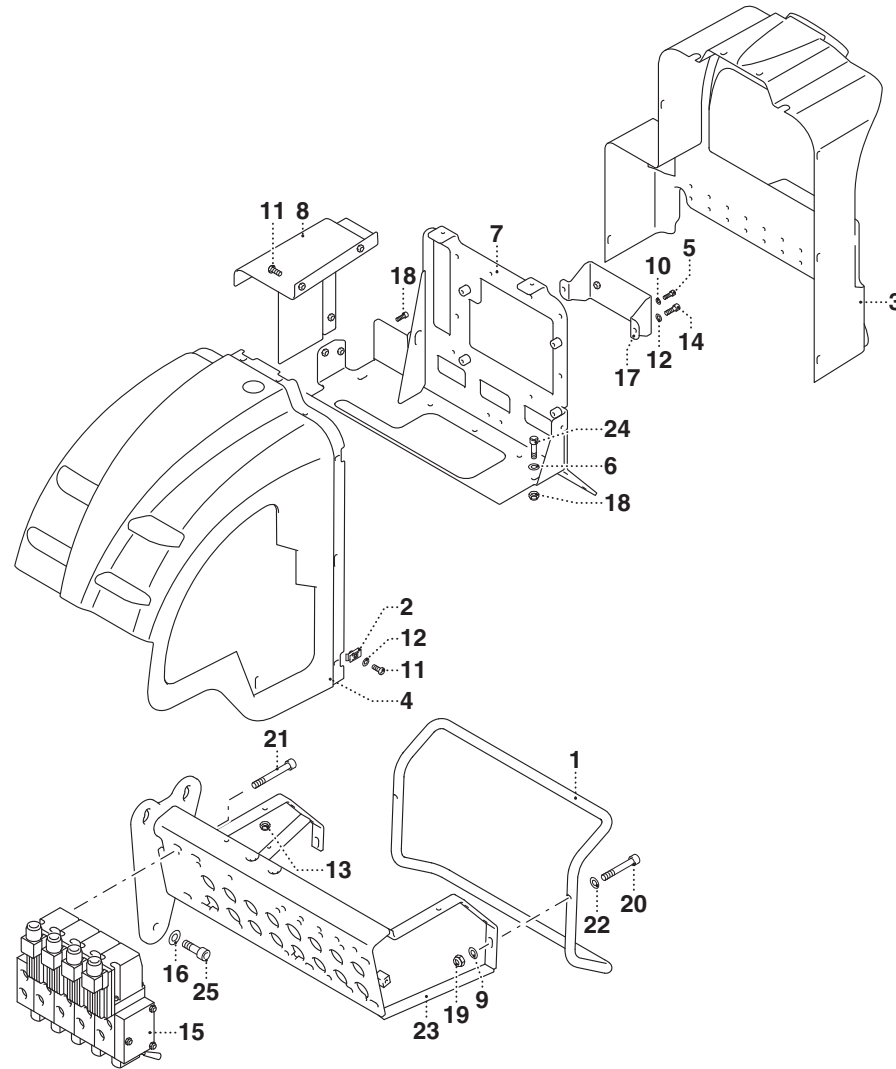

PM 23 P

matr. G107.0005

TAV. GI.01.04

POS.	N° CODICE	Q.	DESCRIZIONE	DESIGNATION	BENENNUNG	DESCRIPTION	DENOMINACIONES
1	403084	1	PROTEZIONE	PROTECTION	SCHUTZ	GUARD	PROTECCION
2	353124	5	MORSETTO	ETAU	KLEMME	CLAMP	PRENSOR
3	176316	1	CARTER	CARTER	GEHÄUSE	CASING	CARTER
4	176315	1	CARTER	CARTER	GEHÄUSE	CASING	CARTER
5	497111	2	VITE	VIS	SCHRAUBE	SCREW	TORNILLO
6	417003	6	RONDELLA	RONDELLE	SCHEIBE	WASHER	ARANDELA
7	466964	1	SUPPORTO	SUPPORT	TRÄGER	SUPPORT	SOPORTE
8	176364	1	CARTER	CARTER	GEHÄUSE	CASING	CARTER
9	417004	2	RONDELLA	RONDELLE	SCHEIBE	WASHER	ARANDELA
10	417050	2	RONDELLA	RONDELLE	SCHEIBE	WASHER	ARANDELA
11	497437	15	VITE	VIS	SCHRAUBE	SCREW	TORNILLO
12	417024	21	RONDELLA	RONDELLE	SCHEIBE	WASHER	ARANDELA
13	191168	2	DADO	ECROU	MUTTER	NUT	TUERCA
14	497225	4	VITE	VIS	SCHRAUBE	SCREW	TORNILLO
15	197568	1	DISTRIBUTORE - 4 ELEMENTI	DISTRIBUTEUR - 4 ELEM.	STEUERVENTIL - 4 ELEM.	CONTROL VALVE B. - 4 ELEM.	DISTRIBUIDOR - 4 ELEM.
15	197569	1	DISTRIBUTORE - 5 ELEMENTI	DISTRIBUTEUR - 5 ELEM.	STEUERVENTIL - 5 ELEM.	CONTROL VALVE B. - 5 ELEM.	DISTRIBUIDOR - 5 ELEM.
15	197571	1	DISTRIBUTORE - 5 ELEMENTI - ARGANO	DISTRIBUTEUR - 5 ELEM. - TREUIL	STEUERVENTIL - 5 ELEM. - WINDE	CONTROL VALVE B. - 5 ELEM. - WINCH	DISTRIB. - 5 ELEM. - CABRESTANTE
15	197570	1	DISTRIBUTORE - 6 ELEMENTI	DISTRIBUTEUR - 6 ELEM.	STEUERVENTIL - 6 ELEM.	CONTROL VALVE B. - 6 ELEM.	DISTRIBUIDOR - 6 ELEM.
15	197572	1	DISTRIBUTORE - 6 EL. - PR. ARTICOLATA	DISTRIBUTEUR - 6 EL. - RALL. ART.	STEUERVENTIL - 6 EL. - GELENKVER.	CONTROL VALVE B. - 6 EL. - JIB	DISTRIBUIDOR - 6 EL. - EXT. ART.
15	197573	1	DISTRIBUTORE - 7 EL. - ARGANO - PROLUNGA ART.	DISTRIBUTEUR - 7 EL. - TREUIL - RALL. ART.	STEUERVENTIL - 7 EL. - WINDE - GELENKVER.	CONTROL VALVE B. - 7 EL. - WINCH - JIB	DISTRIBUIDOR - 7 EL. - CABR. - EX. A.
16	417026	3	RONDELLA	RONDELLE	SCHEIBE	WASHER	ARANDELA
17	467116	1	SUPPORTO	SUPPORT	TRÄGER	SUPPORT	SOPORTE
18	497588	2	VITE	VIS	SCHRAUBE	SCREW	TORNILLO
19	191125	6	DADO	ECROU	MUTTER	NUT	TUERCA
20	497134	2	VITE	VIS	SCHRAUBE	SCREW	TORNILLO
21	497130	4	VITE	VIS	SCHRAUBE	SCREW	TORNILLO



COMANDO - DANFOSS (P.T.) (23 P)

- * *Commande - DANFOSS (P.T.)*
- * *Steuerung - DANFOSS (P.T.)*
- * *Control - DANFOSS (P.T.)*
- * *Mando - DANFOSS (P.T.)*

TAV. GI.01.04

matr. G107.0005

21
23 P

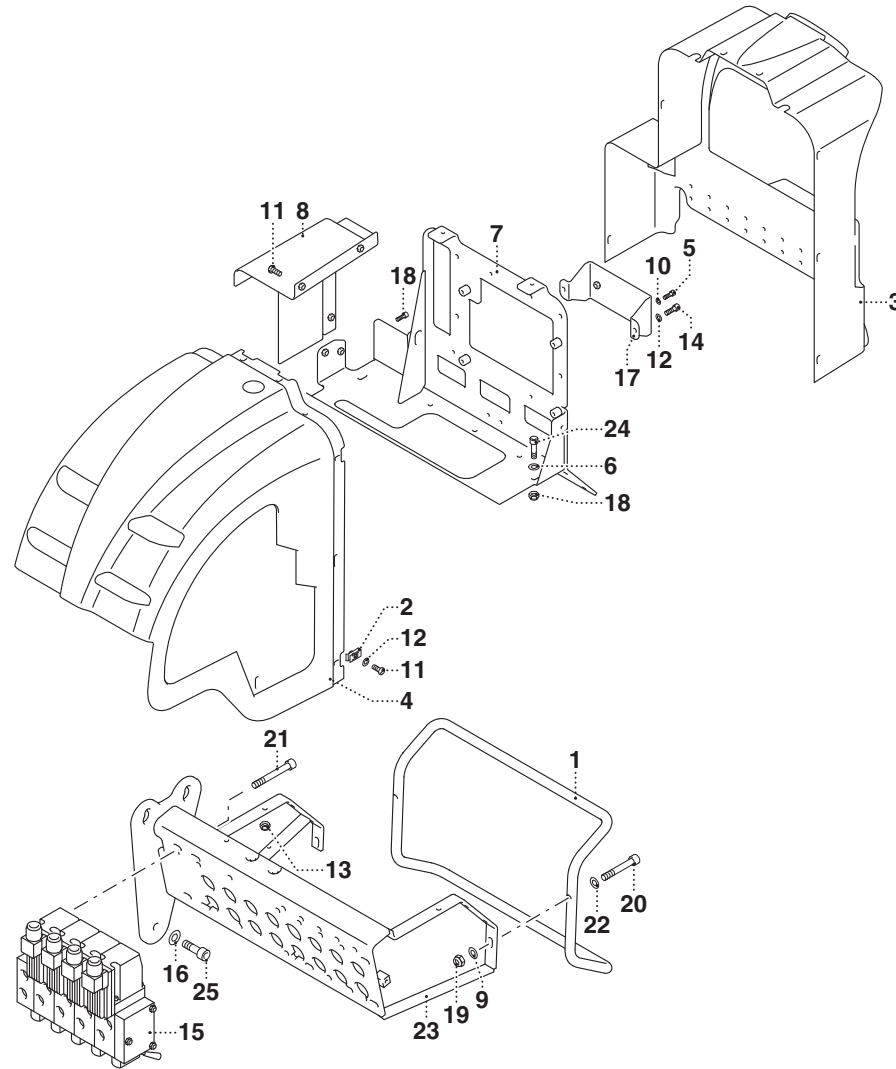



DOPPIO COMANDO - HYDROCONTROL - 3° PUNTO DI MANOVRA (21)

* Double commande - HYDROCONTROL - 3ème point de manoeuvre
* Zweiseitige Steuerung - HYDROCONTROL - 3. Manöverplatz
* Dual side control - HYDROCONTROL - 3rd manoeuvre position
* Mando bilateral - HYDROCONTROL - 3er punto de maniobra

TAV. GI.01.05

matr. G107.0005

21
23 P

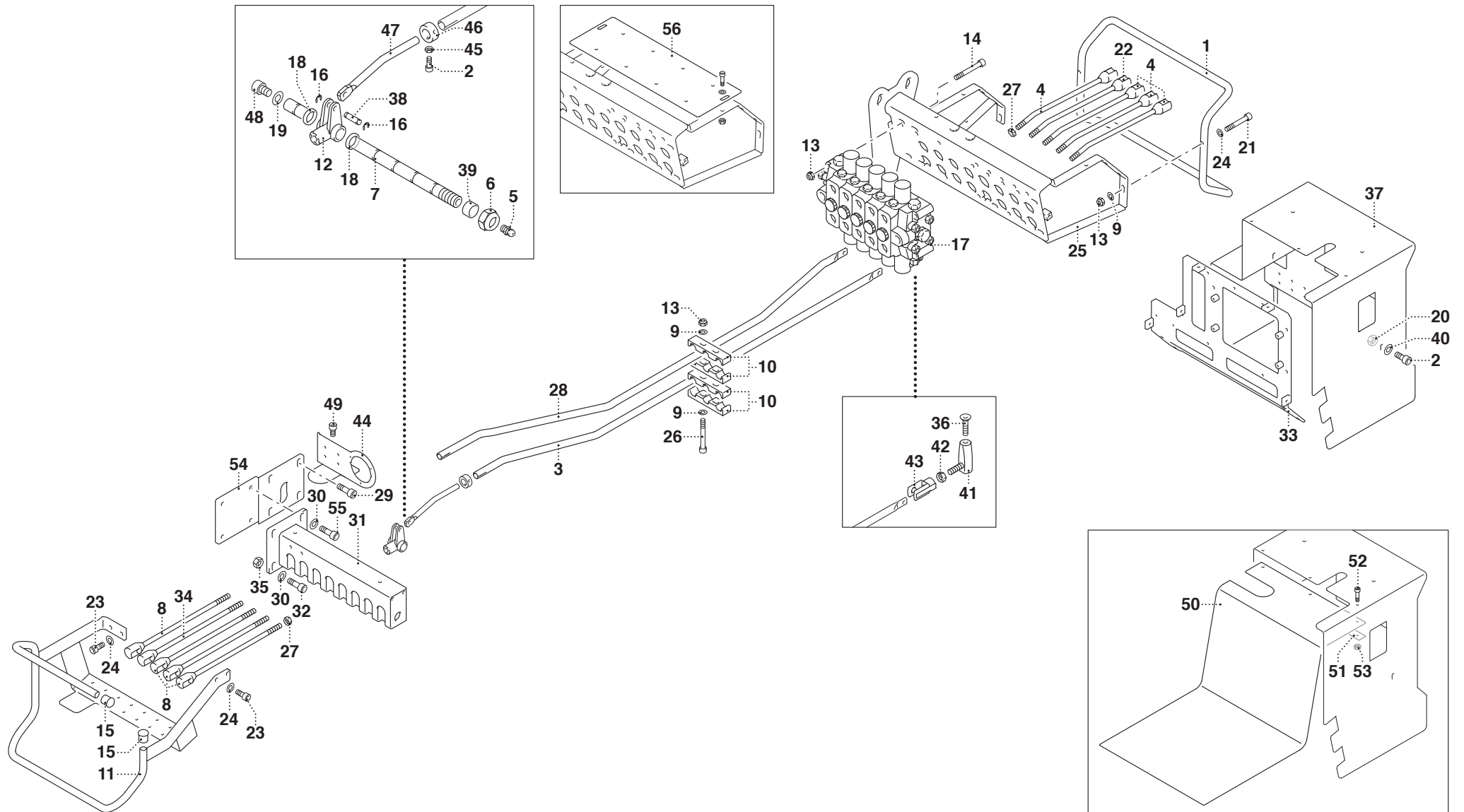

PM 21

matr. G107.0005

TAV. GI.01.05

POS.	N° CODICE	Q.	DESCRIZIONE	DESIGNATION	BENENNUNG	DESCRIPTION	DENOMINACIONES
1	403084	1	PROTEZIONE	PROTECTION	SCHUTZ	GUARD	PROTECCION
2	497118	9	VITE	VIS	SCHRAUBE	SCREW	TORNILLO
3	481265	3	TIRANTE	TIRANT	ZUGSTANGE	TIE ROD	TIRANTE
4	120031	4	LEVA	LEVIER	HEBEL	LEVER	PALANCA
5	281005	1	INGRASSATORE	GRAISSEUR	SCHMIERER	GREASE FITTING	ENGRASADOR
6	191121	1	DADO	ECROU	MUTTER	NUT	TUERCA
7	379776	1	PERNO	AXE	BOLZEN	PIN	PERNO
8	120635	4	LEVA	LEVIER	HEBEL	LEVER	PALANCA
9	417004	12	RONDELLA	RONDELLE	SCHEIBE	WASHER	ARANDELA
10	353068	2	MORSETTO	ETAU	KLEMME	CLAMP	PRENSOR
11	403279	1	PROTEZIONE	PROTECTION	SCHUTZ	GUARD	PROTECCION
12	131013	7	BIELLA	BIELLE	PLEUELSTANGE	LINKBAR	BIELA
13	191168	5	DADO	ECROU	MUTTER	NUT	TUERCA
14	498038	4	VITE	VIS	SCHRAUBE	SCREW	TORNILLO
15	385004	2	TAPPO	BOUCHON	VERSCHLUSSDECKEL	PLUG	TAPON
16	109159	14	ANELLO	BAGUE	RING	RING	ANILLO
17	197665	1	DISTRIBUTORE - 5 ELEMENTI	DISTRIBUTEUR - 5 ELEM.	STEUERVENTIL - 5 ELEM.	CONTROL VALVE B. - 5 ELEM.	DISTRIBUIDOR - 5 ELEM.
17	197667	1	DISTRIBUTORE - 6 ELEMENTI	DISTRIBUTEUR - 6 ELEM.	STEUERVENTIL - 6 ELEM.	CONTROL VALVE B. - 6 ELEM.	DISTRIBUIDOR - 6 ELEM.
17	197668	1	DISTRIBUTORE - 7 ELEMENTI	DISTRIBUTEUR - 7 ELEM.	STEUERVENTIL - 7 ELEM.	CONTROL VALVE B. - 7 ELEM.	DISTRIBUIDOR - 7 ELEM.
17	197666	1	DISTRIBUTORE - 6 ELEMENTI - ARGANO	DISTRIBUTEUR - 6 ELEM. - TREUIL	STEUERVENTIL - 6 ELEM. - WINDE	CONTROL VALVE B. - 6 ELEM. - WINCH	DISTRIB. - 6 ELEM. - CABRESTANTE
18	136127	7	DISTANZIALE	ENTRETOISE	DISTANZSTÜCK	SPACER	DISTANCIADOR
19	417027	1	RONDELLA	RONDELLE	SCHEIBE	WASHER	ARANDELA
20	191125	4	DADO	ECROU	MUTTER	NUT	TUERCA
21	497134	2	VITE	VIS	SCHRAUBE	SCREW	TORNILLO
22	120033	1	LEVA	LEVIER	HEBEL	LEVER	PALANCA
23	497130	6	VITE	VIS	SCHRAUBE	SCREW	TORNILLO



DOPPIO COMANDO - HYDROCONTROL - 3° PUNTO DI MANOVRA (21)

* Double commande - HYDROCONTROL - 3ème point de manoeuvre
* Zweiseitige Steuerung - HYDROCONTROL - 3. Manöverplatz
* Dual side control - HYDROCONTROL - 3rd manoeuvre position
* Mando bilateral - HYDROCONTROL - 3er punto de maniobra

TAV. GI.01.05

matr. G107.0005

21
23 P

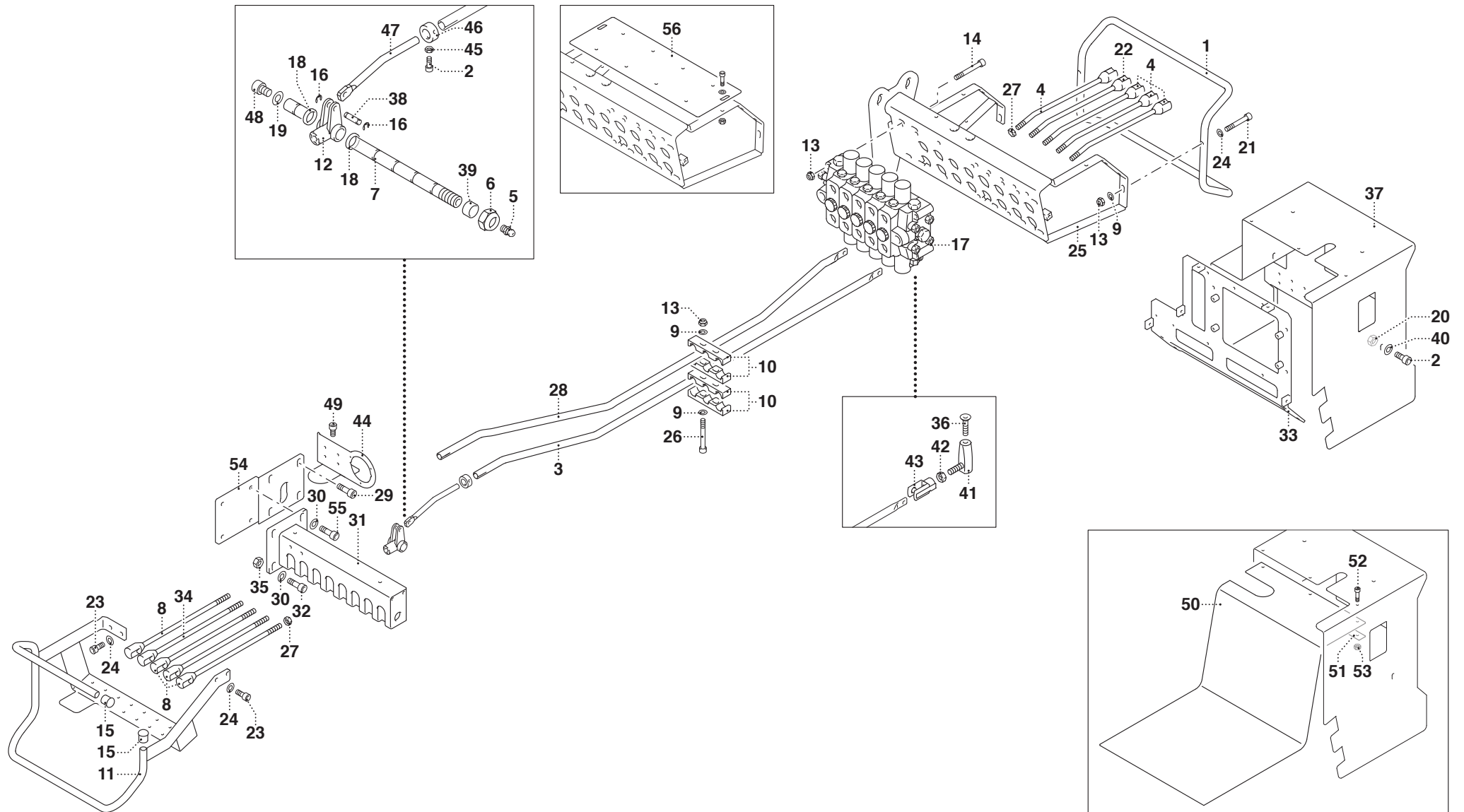

PM 21

matr. G107.0005

TAV. GI.01.05

POS. N° CODICE	Q.	DESCRIZIONE	DESIGNATION	BENENNUNG	DESCRIPTION	DENOMINACIONES	
24	417025	11	RONDELLA	RONDELLE	SCHEIBE	WASHER	ARANDELA
25	467598	1	SUPPORTO	SUPPORT	TRÄGER	SUPPORT	SOPORTE
26	497141	2	VITE	VIS	SCHRAUBE	SCREW	TORNILLO
27	191064	10	DADO	ECROU	MUTTER	NUT	TUERCA
28	481266	2	TIRANTE	TIRANT	ZUGSTANGE	TIE ROD	TIRANTE
29	497145	2	VITE	VIS	SCHRAUBE	SCREW	TORNILLO
30	417026	8	RONDELLA	RONDELLE	SCHEIBE	WASHER	ARANDELA
31	466343	1	SUPPORTO	SUPPORT	TRÄGER	SUPPORT	SOPORTE
32	497147	2	VITE	VIS	SCHRAUBE	SCREW	TORNILLO
33	467446	1	CARTER	CARTER	GEHÄUSE	CASING	CARTER
34	120634	1	LEVA	LEVIER	HEBEL	LEVER	PALANCA
35	191045	2	DADO	ECROU	MUTTER	NUT	TUERCA
36	498099	5	VITE	VIS	SCHRAUBE	SCREW	TORNILLO
37	176396	1	CARTER	CARTER	GEHÄUSE	CASING	CARTER
38	379322	7	PERNO	AXE	BOLZEN	PIN	PERNO
39	136089	1	DISTANZIALE	ENTRETOISE	DISTANZSTÜCK	SPACER	DISTANCIADOR
40	417024	4	RONDELLA	RONDELLE	SCHEIBE	WASHER	ARANDELA
41	379727	5	PERNO	AXE	BOLZEN	PIN	PERNO
42	191063	5	DADO	ECROU	MUTTER	NUT	TUERCA
43	220018	5	FORCELLA	FOURCHE	GABEL	CLEVIS	HORQUILLA
44	467613	1	SUPPORTO	SUPPORT	TRÄGER	SUPPORT	SOPORTE
45	191062	5	DADO	ECROU	MUTTER	NUT	TUERCA
46	112167	5	BOCCOLA	DOUILLE	BUCHSE	BUSHING	CASQUILLO
47	283021	5	TIRANTE	TIRANT	ZUGSTANGE	TIE ROD	TIRANTE
48	497159	1	VITE	VIS	SCHRAUBE	SCREW	TORNILLO
49	497129	2	VITE	VIS	SCHRAUBE	SCREW	TORNILLO



DOPPIO COMANDO - HYDROCONTROL - 3° PUNTO DI MANOVRA (21)

* Double commande - HYDROCONTROL - 3ème point de manoeuvre
* Zweiseitige Steuerung - HYDROCONTROL - 3. Manöverplatz
* Dual side control - HYDROCONTROL - 3rd manoeuvre position
* Mando bilateral - HYDROCONTROL - 3er punto de maniobra

TAV. GI.01.05

matr. G107.0005

21
23 P

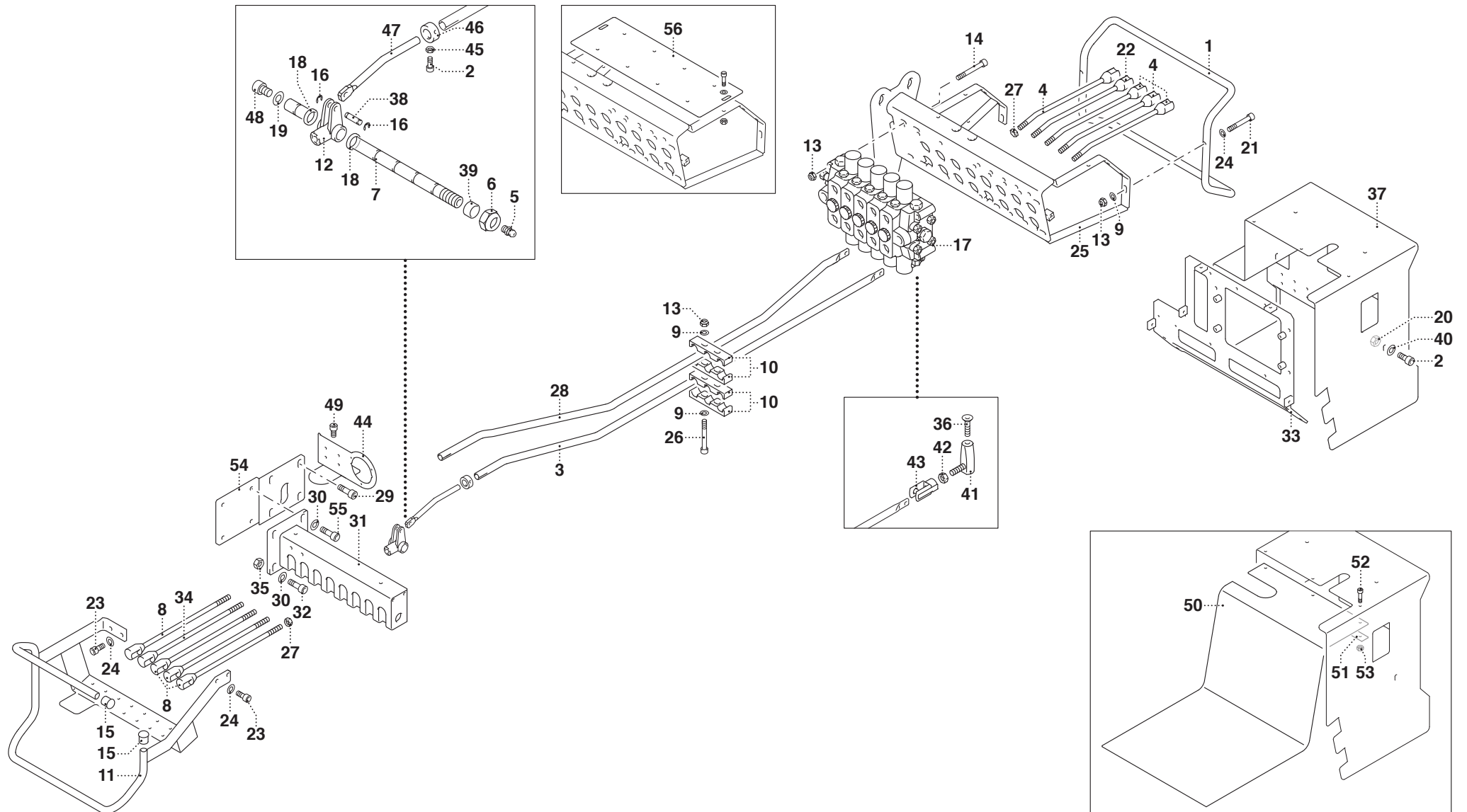

PM 21

matr. G107.0005

TAV. GI.01.05

POS. N° CODICE	Q.	DESCRIZIONE	DESIGNATION	BENENNUNG	DESCRIPTION	DENOMINACIONES	
50	262183	1	PROTEZIONE	PROTECTION	SCHUTZ	GUARD	PROTECCION
51	467900	1	SUPPORTO	SUPPORT	TRÄGER	SUPPORT	SOPORTE
52	497107	3	VITE	VIS	SCHRAUBE	SCREW	TORNILLO
53	191155	3	DADO	ECROU	MUTTER	NUT	TUERCA
54	467869	1	SUPPORTO	SUPPORT	TRÄGER	SUPPORT	SOPORTE
55	497907	4	VITE	VIS	SCHRAUBE	SCREW	TORNILLO
56	467892	1	SUPPORTO	SUPPORT	TRÄGER	SUPPORT	SOPORTE



DOPPIO COMANDO - DANFOSS - 3° PUNTO DI MANOVRA (23 P)

- * Double commande - DANFOSS - 3ème point de manœuvre
- * Zweiseitige Steuerung - DANFOSS - 3. Manöverplatz
- * Dual side control - DANFOSS - 3rd manoeuvre position
- * Mando bilateral - DANFOSS - 3er punto de maniobra

TAV. GI.01.06

matr. G107.0005

21
23 P

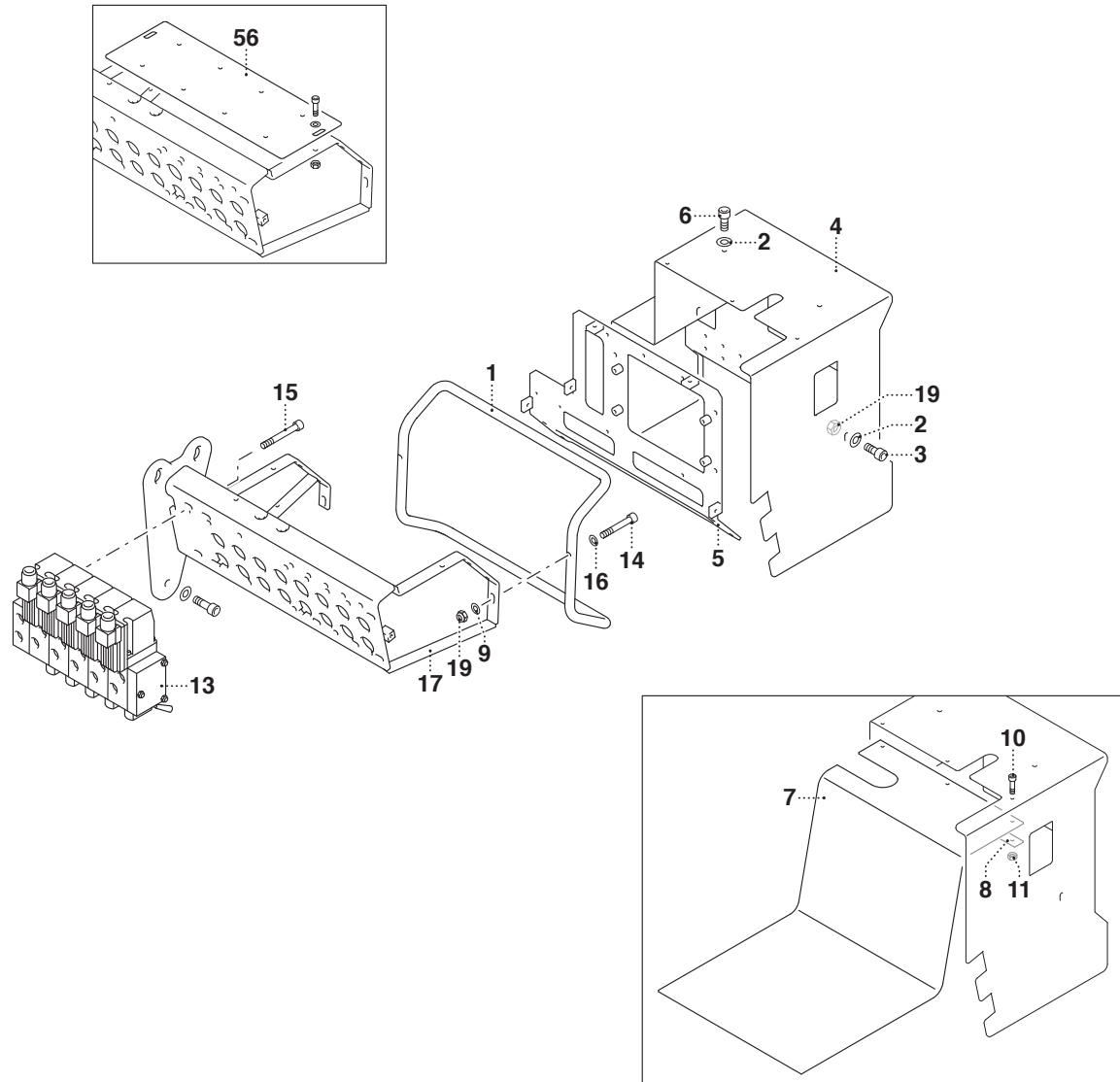

PM 23 P

matr. G107.0005

TAV. GI.01.06

POS.	N° CODICE	Q.	DESCRIZIONE	DESIGNATION	BENENNUNG	DESCRIPTION	DENOMINACIONES
1	403084	1	PROTEZIONE	PROTECTION	SCHUTZ	GUARD	PROTECCION
2	417024	10	RONDELLA	RONDELLE	SCHEIBE	WASHER	ARANDELA
3	497119	4	VITE	VIS	SCHRAUBE	SCREW	TORNILLO
4	176396	1	CARTER	CARTER	GEHÄUSE	CASING	CARTER
5	467446	1	COPERCHIO	COUVERCLE	DECKEL	COVER	TAPA
6	497225	6	VITE	VIS	SCHRAUBE	SCREW	TORNILLO
7	282183	1	PROTEZIONE	PROTECTION	SCHUTZ	GUARD	PROTECCION
8	467900	1	SUPPORTO	SUPPORT	TRÄGER	SUPPORT	SOPORTE
9	417004	2	RONDELLA	RONDELLE	SCHEIBE	WASHER	ARANDELA
10	497107	3	VITE	VIS	SCHRAUBE	SCREW	TORNILLO
11	191155	3	DADO	ECROU	MUTTER	NUT	TUERCA
12	467892	1	SUPPORTO	SUPPORT	TRÄGER	SUPPORT	SOPORTE
13	197568	1	DISTRIBUTORE - 4 ELEMENTI	DISTRIBUTEUR - 4 ELEM.	STEUERVENTIL - 4 ELEM.	CONTROL VALVE B. - 4 ELEM.	DISTRIBUIDOR - 4 ELEM.
13	197569	1	DISTRIBUTORE - 5 ELEMENTI	DISTRIBUTEUR - 5 ELEM.	STEUERVENTIL - 5 ELEM.	CONTROL VALVE B. - 5 ELEM.	DISTRIBUIDOR - 5 ELEM.
13	197571	1	DISTRIBUTORE - 5 ELEMENTI - ARGANO	DISTRIBUTEUR - 5 ELEM. - TREUIL	STEUERVENTIL - 5 ELEM. - WINDE	CONTROL VALVE B. - 5 ELEM. - WINCH	DISTRIBUIDOR - 5 EL. - CABR.
13	197570	1	DISTRIBUTORE - 6 ELEMENTI	DISTRIBUTEUR - 6 ELEM.	STEUERVENTIL - 6 ELEM.	CONTROL VALVE B. - 6 ELEM.	DISTRIBUIDOR - 6 ELEM.
13	197572	1	DISTRIBUTORE - 6 EL. - PR. ARTICOLATA	DISTRIBUTEUR - 6 EL. - RALL. ART.	STEUERVENTIL - 6 EL. - GELENKVER.	CONTROL VALVE B. - 6 EL. - JIB	DISTRIBUIDOR - 6 EL. - EXT. ART.
13	197573	1	DISTRIBUTORE - 7 EL. - ARGANO - PROLUNGA ART.	DISTRIBUTEUR - 7 EL. - TREUIL - RALL. ART.	STEUERVENTIL - 7 EL. - WINDE - GELENKVER.	CONTROL VALVE B. - 7 EL. - WINCH - JIB	DISTRIBUIDOR - 7 EL. - CABR. - EX. A.
14	497134	2	VITE	VIS	SCHRAUBE	SCREW	TORNILLO
15	497130	4	VITE	VIS	SCHRAUBE	SCREW	TORNILLO
16	417025	7	RONDELLA	RONDELLE	SCHEIBE	WASHER	ARANDELA
17	467598	1	SUPPORTO	SUPPORT	TRÄGER	SUPPORT	SOPORTE



DOPPIO COMANDO - STABILIZZATORI

- * Double commande - Stabilisateurs
- * Zweiseitige Steuerung - Stabilisatoren
- * Dual side control - Outriggers
- * Mando bilateral - Estabilizadores

TAV. GI.02.01

matr. G107.0005

21
23 P

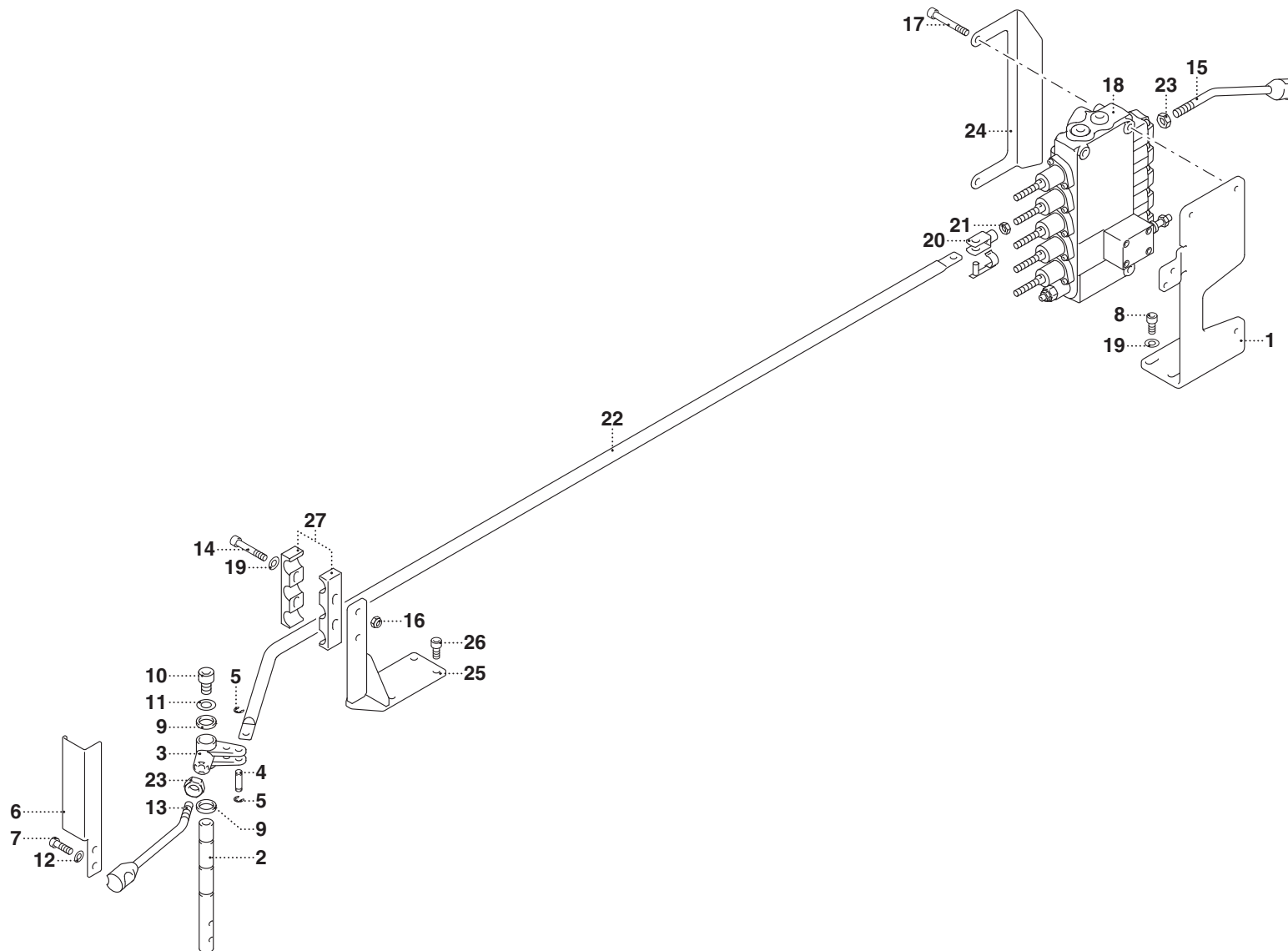

PM 21 - PM 23 P

matr. G107.0005

TAV. GI.02.01

POS.	N° CODICE	Q.	DESCRIZIONE	DESIGNATION	BENENNUNG	DESCRIPTION	DENOMINACIONES
1	467513	1	SUPPORTO	SUPPORT	TRÄGER	SUPPORT	SOPORTE
2	380432	1	PERNO	AXE	BOLZEN	PIN	PERNO
3	131021	3	FORCELLA	FOURCHE	GABEL	CLEVIS	HORQUILLA
4	379322	3	PERNO	AXE	BOLZEN	PIN	PERNO
5	109159	6	ANELLO	BAGUE	RING	RING	ANILLO
6	467596	1	SUPPORTO	SUPPORT	TRÄGER	SUPPORT	SOPORTE
7	497383	2	VITE	VIS	SCHRAUBE	SCREW	TORNILLO
8	497130	4	VITE	VIS	SCHRAUBE	SCREW	TORNILLO
9	136127	6	DISTANZIALE	ENTRETOISE	DISTANZSTÜCK	SPACER	DISTANCIADOR
10	497159	1	VITE	VIS	SCHRAUBE	SCREW	TORNILLO
11	417006	1	RONDELLA	RONDELLE	SCHEIBE	WASHER	ARANDELA
12	417025	2	RONDELLA	RONDELLE	SCHEIBE	WASHER	ARANDELA
13	120989	3	LEVA	LEVIER	HEBEL	LEVER	PALANCA
14	497137	2	VITE	VIS	SCHRAUBE	SCREW	TORNILLO
15	120997	3	LEVA	LEVIER	HEBEL	LEVER	PALANCA
16	191168	2	DADO	ECROU	MUTTER	NUT	TUERCA
17	497138	3	VITE	VIS	SCHRAUBE	SCREW	TORNILLO
18	197534	1	DISTRIBUTORE	DISTRIBUTEUR	STEUERVENTIL	CONTROL VALVE BLOCK	DISTRIBUIDOR
19	417004	6	RONDELLA	RONDELLE	SCHEIBE	WASHER	ARANDELA
20	220018	3	FORCELLA	FOURCHE	GABEL	CLEVIS	HORQUILLA
21	191063	3	DADO	ECROU	MUTTER	NUT	TUERCA
22	481335	3	TIRANTE	TIRANT	ZUGSTANGE	TIE ROD	TIRANTE
23	191064	6	DADO	ECROU	MUTTER	NUT	TUERCA
24	176395	1	CARTER	CARTER	GEHÄUSE	CASING	CARTER
25	467608	1	SUPPORTO	SUPPORT	TRÄGER	SUPPORT	SOPORTE
26	497131	4	VITE	VIS	SCHRAUBE	SCREW	TORNILLO



DOPPIO COMANDO - STABILIZZATORI

- * Double commande - Stabilisateurs
- * Zweiseitige Steuerung - Stabilisatoren
- * Dual side control - Outriggers
- * Mando bilateral - Estabilizadores

TAV. GI.02.01

matr. G107.0005

21
23 P

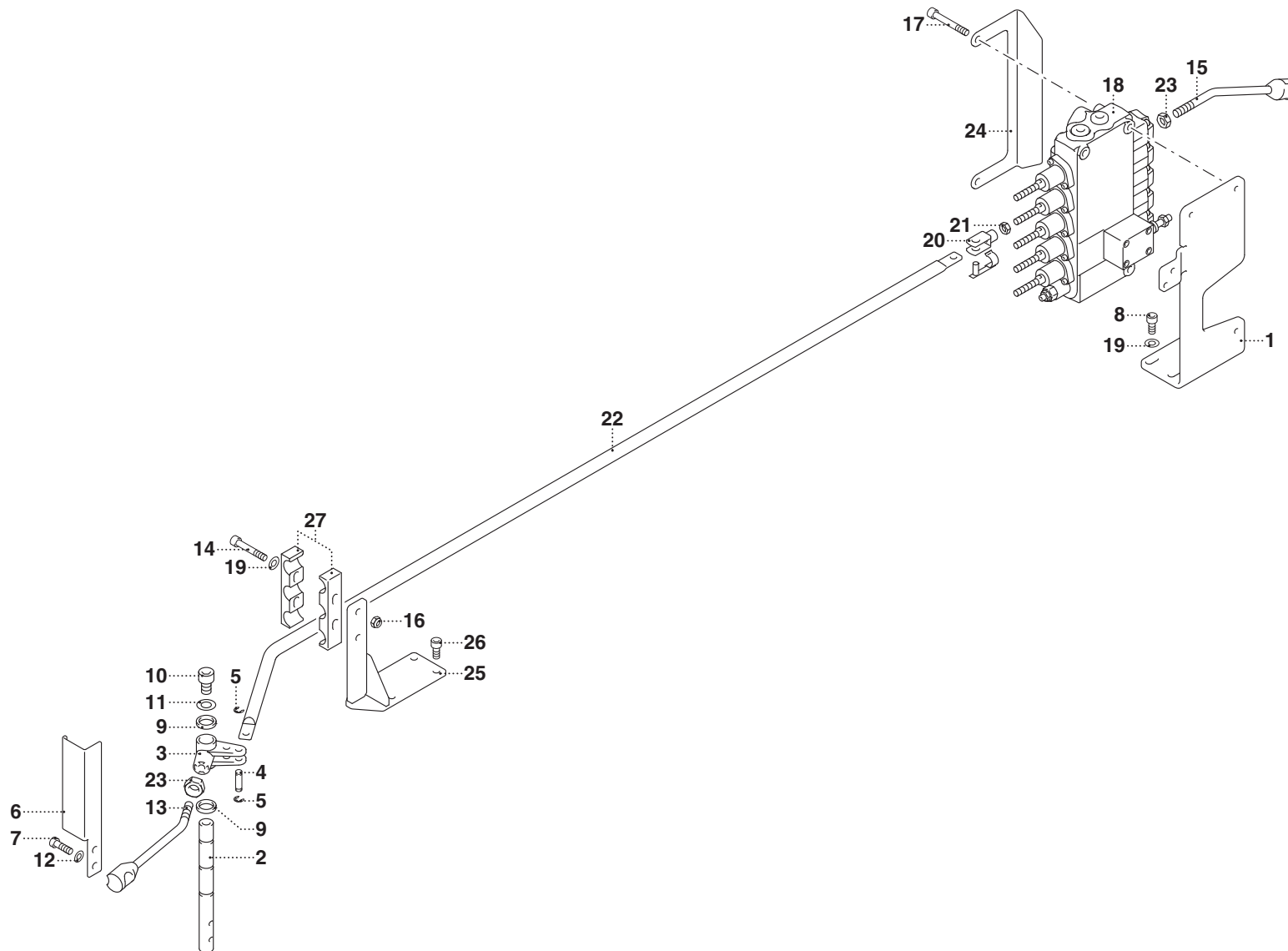



TELAIO 3° PUNTO DI MANOVRA - HYDROCONTROL (MANUALE)

- * Châssis 3ème point de manœuvre - HYDROCONTROL (manuel)
- * Rahmen 3. Manöverplatz - HYDROCONTROL (manuelle)
- * Frame for the 3rd manoeuvre position - HYDROCONTROL (manual)
- * Bastidor 3er punto de maniobra - HYDROCONTROL (manual)

TAV. GI.03.01

matr. G107.0005

21
23 P

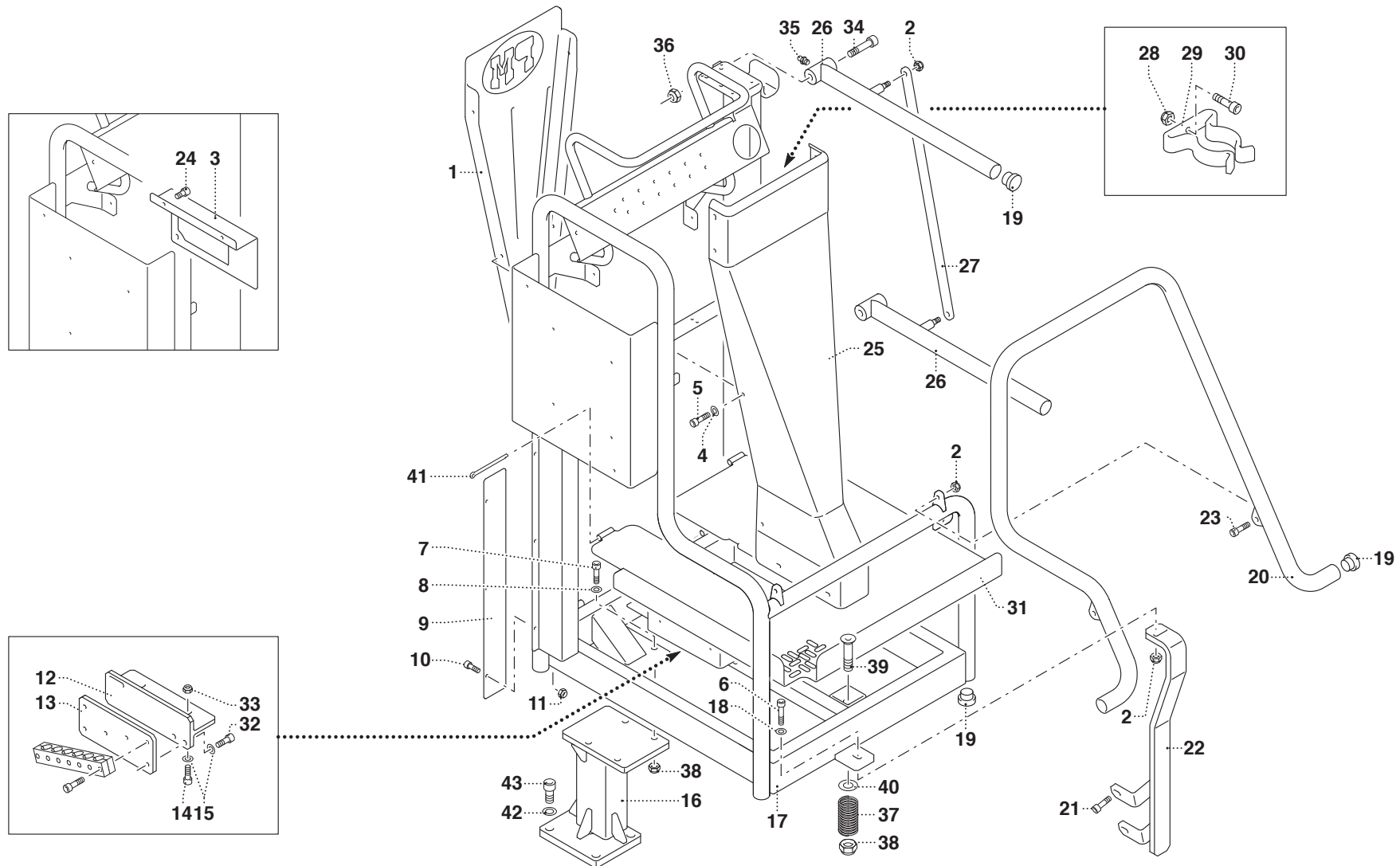

PM 21 - PM 23 P

matr. G107.0005

TAV. GI.03.01

POS.	N° CODICE	Q.	DESCRIZIONE	DESIGNATION	BENENNUNG	DESCRIPTION	DENOMINACIONES
1	176245	1	CARTER	CARTER	GEHÄUSE	CASING	CARTER
2	191168	15	DADO	ECROU	MUTTER	NUT	TUERCA
3	176455	1	SUPPORTO	SUPPORT	TRÄGER	SUPPORT	SOPORTE
4	417001	12	RONDELLA	RONDELLE	SCHEIBE	WASHER	ARANDELA
5	497107	12	VITE	VIS	SCHRAUBE	SCREW	TORNILLO
6	497135	1	VITE	VIS	SCHRAUBE	SCREW	TORNILLO
7	497148	4	VITE	VIS	SCHRAUBE	SCREW	TORNILLO
8	417026	4	RONDELLA	RONDELLE	SCHEIBE	WASHER	ARANDELA
9	176239	1	CARTER	CARTER	GEHÄUSE	CASING	CARTER
10	497111	5	VITE	VIS	SCHRAUBE	SCREW	TORNILLO
11	191046	3	DADO	ECROU	MUTTER	NUT	TUERCA
12	307026	1	SUPPORTO	SUPPORT	TRÄGER	SUPPORT	SOPORTE
13	310175	1	PIASTRA	PLAQUE	PLATTE	PLATE	PLACA
14	497120	6	VITE	VIS	SCHRAUBE	SCREW	TORNILLO
15	417024	4	RONDELLA	RONDELLE	SCHEIBE	WASHER	ARANDELA
16	467737	1	SUPPORTO	SUPPORT	TRÄGER	SUPPORT	SOPORTE
17	467898	1	TELAIO	CHASSIS	RAHMEN	FRAME	CHASIS
18	417025	4	RONDELLA	RONDELLE	SCHEIBE	WASHER	ARANDELA
19	471282	7	TAPPO	BOUCHON	VERSCHLUSSDECKEL	PLUG	TAPON
20	403251	1	PROTEZIONE	PROTECTION	SCHUTZ	GUARD	PROTECCION
21	497383	2	VITE	VIS	SCHRAUBE	SCREW	TORNILLO
22	467738	1	SUPPORTO	SUPPORT	TRÄGER	SUPPORT	SOPORTE
23	497251	2	VITE	VIS	SCHRAUBE	SCREW	TORNILLO
24	497119	8	VITE	VIS	SCHRAUBE	SCREW	TORNILLO
25	176244	1	CARTER	CARTER	GEHÄUSE	CASING	CARTER
26	403247	2	PROTEZIONE	PROTECTION	SCHUTZ	GUARD	PROTECCION



TELAIO 3° PUNTO DI MANOVRA - HYDROCONTROL (MANUALE)

- * Châssis 3ème point de manœuvre - HYDROCONTROL (manuel)
- * Rahmen 3. Manöverplatz - HYDROCONTROL (manuelle)
- * Frame for the 3rd manoeuvre position - HYDROCONTROL (manual)
- * Bastidor 3er punto de maniobra - HYDROCONTROL (manual)

TAV. GI.03.01

matr. G107.0005

21
23 P

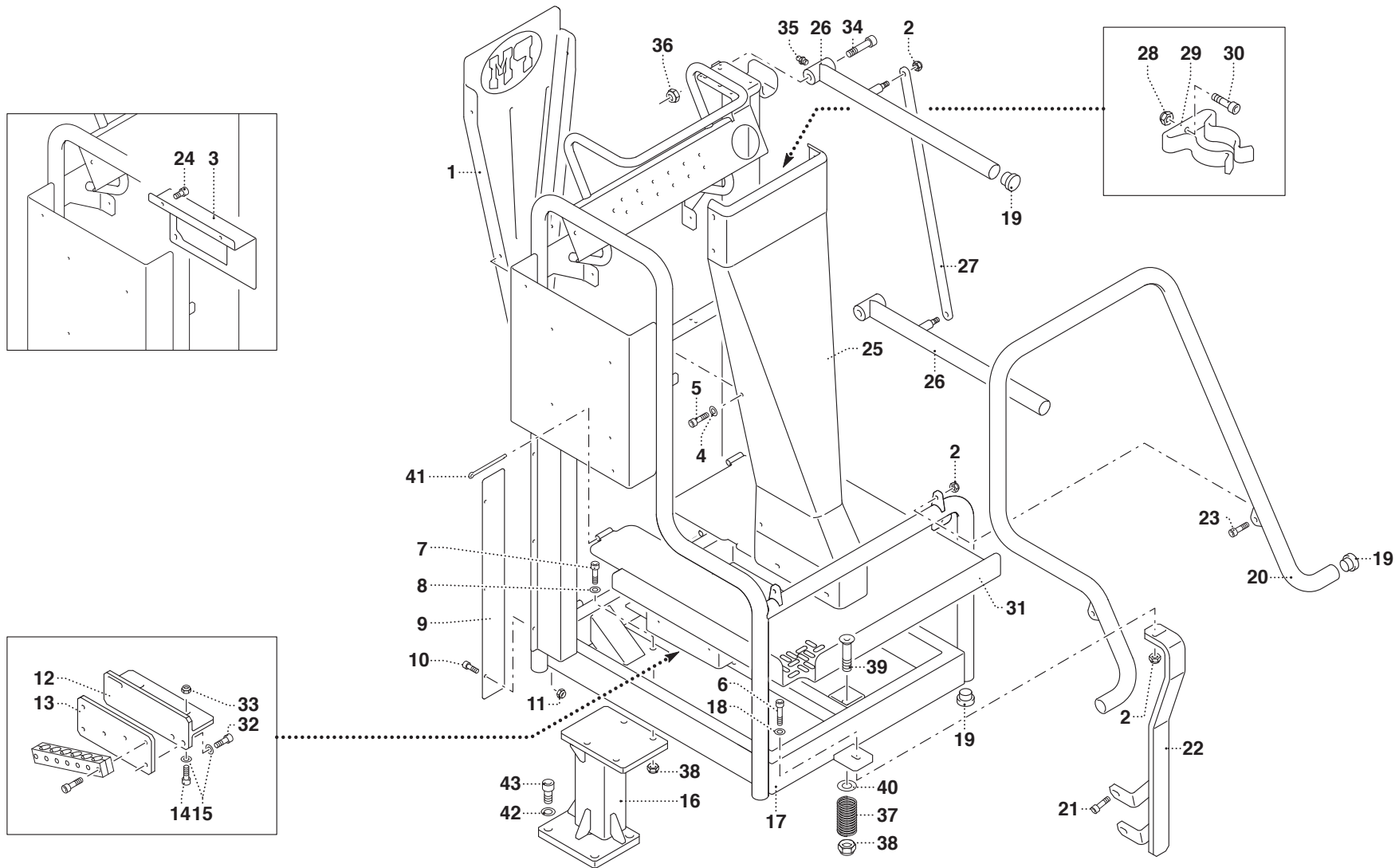

PM 21 - PM 23 P

matr. G107.0005

TAV. GI.03.01

POS.	N° CODICE	Q.	DESCRIZIONE	DESIGNATION	BENENNUNG	DESCRIPTION	DENOMINACIONES
27	132091	1	BIELLA	BIELLE	PLEUELSTANGE	LINKBAR	BIELA
28	191178	2	DADO	ECROU	MUTTER	NUT	TUERCA
29	349131	2	MOLLA	RESSORT	FEDER	SPRING	MUELLE
30	498036	2	VITE	VIS	SCHRAUBE	SCREW	TORNILLO
31	377041	1	PEDANA	ESTRADE	FUSSBRETT	FOOT BOARD	ESTRIBO
32	497119	2	VITE	VIS	SCHRAUBE	SCREW	TORNILLO
33	191162	2	DADO	ECROU	MUTTER	NUT	TUERCA
34	497964	2	VITE	VIS	SCHRAUBE	SCREW	TORNILLO
35	281010	2	INGRASSATORE	GRAISSEUR	SCHMIERER	GREASE FITTING	ENGRASADOR
36	191095	2	DADO	ECROU	MUTTER	NUT	TUERCA
37	349057	1	MOLLA	RESSORT	FEDER	SPRING	MUELLE
38	191045	5	DADO	ECROU	MUTTER	NUT	TUERCA
39	497221	1	VITE	VIS	SCHRAUBE	SCREW	TORNILLO
40	417005	1	RONDELLA	RONDELLE	SCHEIBE	WASHER	ARANDELA
41	177011	2	COPIGLIA	GOUPILLE	SPLINT	SPLIT PIN	PASADOR
42	417028	4	RONDELLA	RONDELLE	SCHEIBE	WASHER	ARANDELA
43	497175	4	VITE	VIS	SCHRAUBE	SCREW	TORNILLO



TELAIO 3° PUNTO DI MANOVRA - RADIOCOMANDO

* Châssis 3ème point de manœuvre - radiocommande
* Rahmen 3. Manöverplatz - Fernsteuerung
* Frame for the 3rd manoeuvre position - radio control
* Bastidor 3er punto de maniobra - radiomando

TAV. GI.03.02

matr. G107.0005

21
23 P

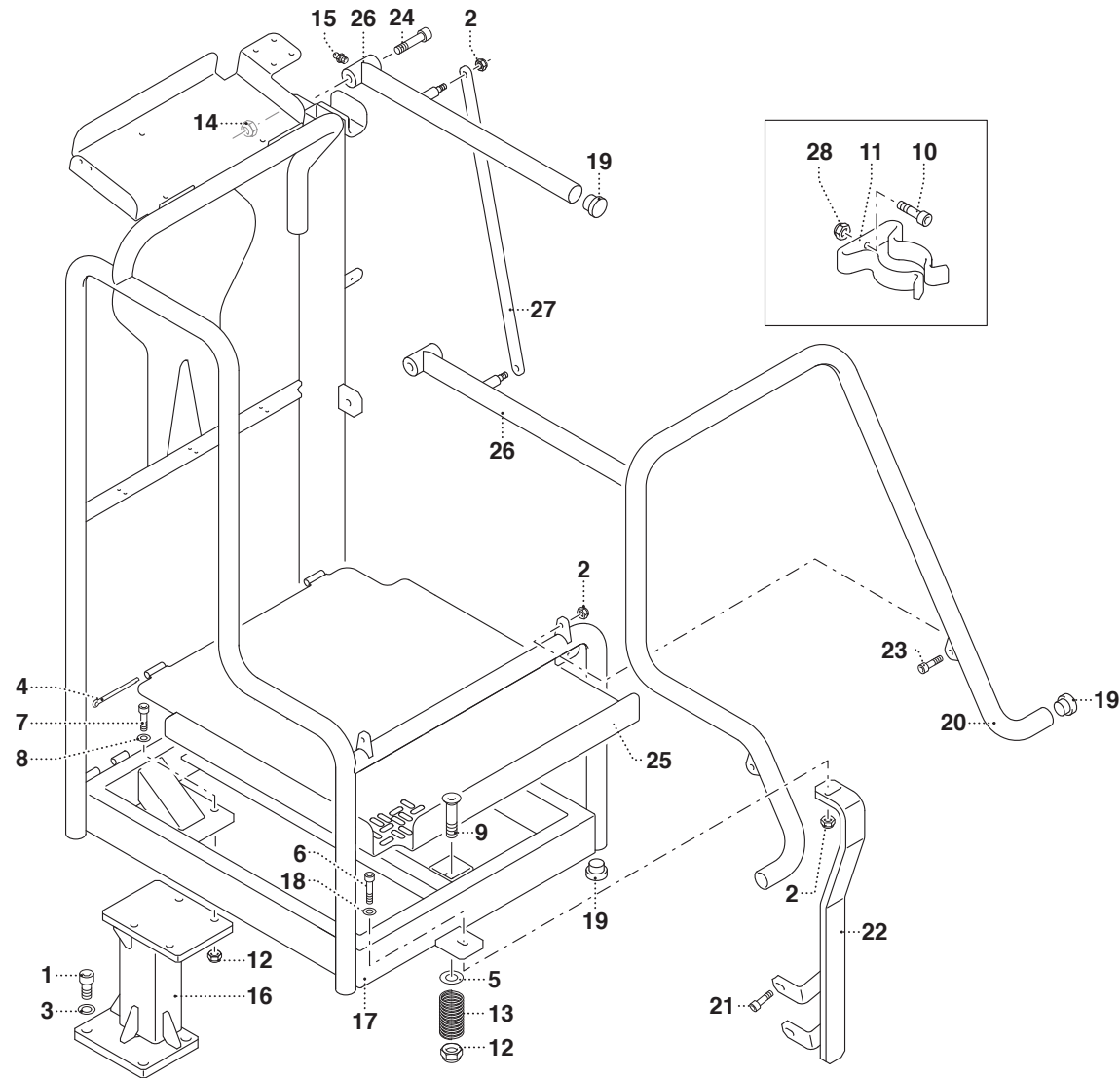

PM 21 - PM 23 P

matr. G107.0005

TAV. GI.03.02

POS.	N° CODICE	Q.	DESCRIZIONE	DESIGNATION	BENENNUNG	DESCRIPTION	DENOMINACIONES
1	197175	4	VITE	VIS	SCHRAUBE	SCREW	TORNILLO
2	191168	15	DADO	ECROU	MUTTER	NUT	TUERCA
3	417028	4	RONDELLA	RONDELLE	SCHEIBE	WASHER	ARANDELA
4	177011	2	COPIGLIA	GOUPILLE	SPLINT	SPLIT PIN	PASADOR
5	417005	1	RONDELLA	RONDELLE	SCHEIBE	WASHER	ARANDELA
6	497135	1	VITE	VIS	SCHRAUBE	SCREW	TORNILLO
7	497148	4	VITE	VIS	SCHRAUBE	SCREW	TORNILLO
8	417026	4	RONDELLA	RONDELLE	SCHEIBE	WASHER	ARANDELA
9	497221	1	VITE	VIS	SCHRAUBE	SCREW	TORNILLO
10	498036	2	VITE	VIS	SCHRAUBE	SCREW	TORNILLO
11	349131	2	MOLLA	RESSORT	FEDER	SPRING	MUELLE
12	191045	5	DADO	ECROU	MUTTER	NUT	TUERCA
13	349057	1	MOLLA	RESSORT	FEDER	SPRING	MUELLE
14	191095	2	DADO	ECROU	MUTTER	NUT	TUERCA
15	281010	2	INGRASSATORE	GRAISSEUR	SCHMIERER	GREASE FITTING	ENGRASADOR
16	467737	1	SUPPORTO	SUPPORT	TRÄGER	SUPPORT	SOPORTE
17	467775	1	TELAIO	CHASSIS	RAHMEN	FRAME	CHASIS
18	417025	4	RONDELLA	RONDELLE	SCHEIBE	WASHER	ARANDELA
19	471282	7	TAPPO	BOUCHON	VERSCHLUSSDECKEL	PLUG	TAPON
20	403251	1	PROTEZIONE	PROTECTION	SCHUTZ	GUARD	PROTECCION
21	497383	2	VITE	VIS	SCHRAUBE	SCREW	TORNILLO
22	467738	1	SUPPORTO	SUPPORT	TRÄGER	SUPPORT	SOPORTE
23	497251	2	VITE	VIS	SCHRAUBE	SCREW	TORNILLO
24	497904	2	VITE	VIS	SCHRAUBE	SCREW	TORNILLO
25	377043	1	PEDANA	ESTRADE	FUSSBRETT	FOOT BOARD	ESTRIBO
26	403247	2	PROTEZIONE	PROTECTION	SCHUTZ	GUARD	PROTECCION



TELAIO 3° PUNTO DI MANOVRA - RADIOCOMANDO

* Châssis 3ème point de manœuvre - radiocommande
* Rahmen 3. Manöverplatz - Fernsteuerung
* Frame for the 3rd manoeuvre position - radio control
* Bastidor 3er punto de maniobra - radiomando

TAV. GI.03.02

matr. G107.0005

21
23 P

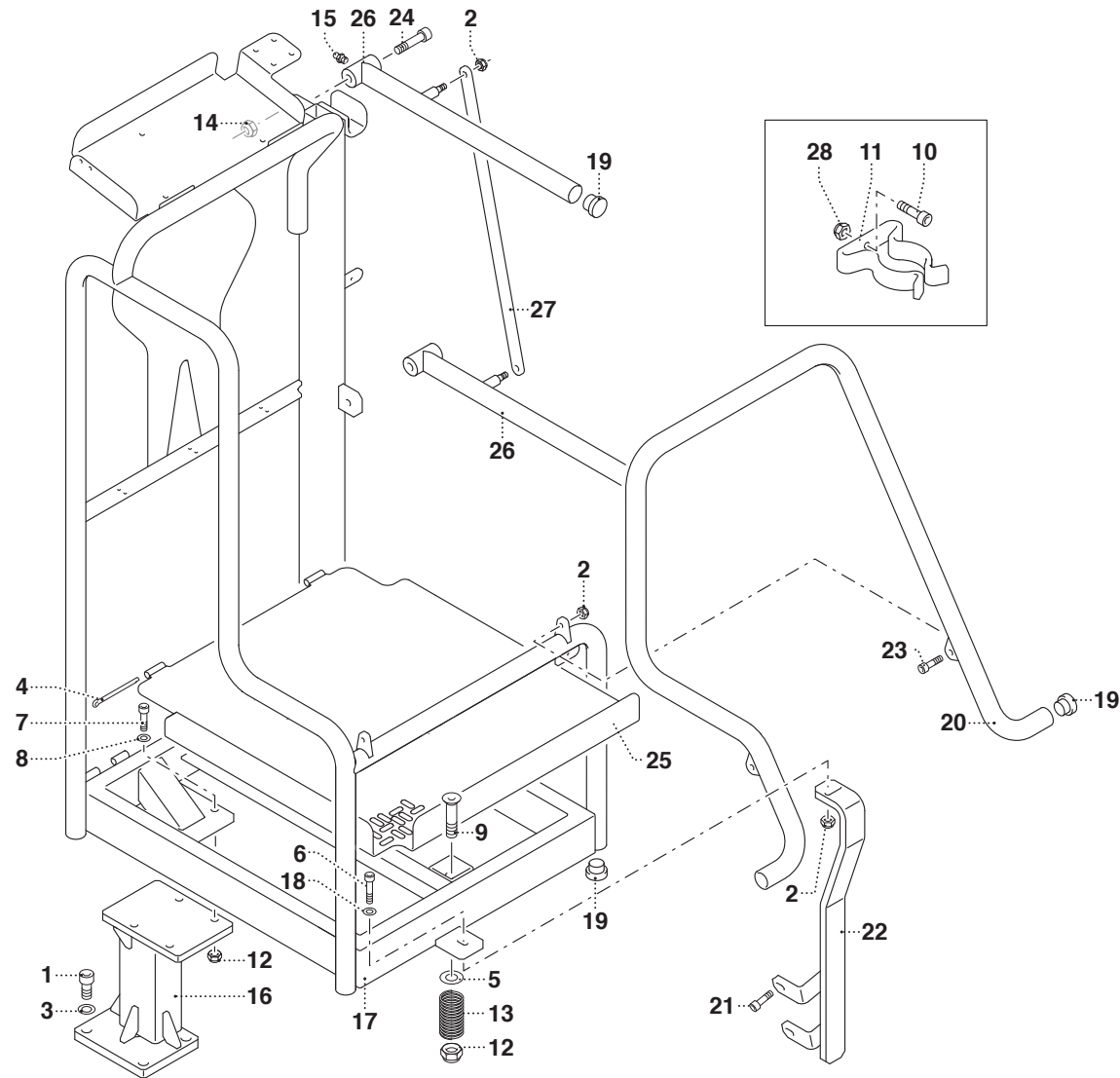



TELAIO 3° PUNTO DI MANOVRA - HYDROCONTROL (MANUALE)

- * Châssis 3ème point de manœuvre - HYDROCONTROL (manuel)
- * Rahmen 3. Manöverplatz - HYDROCONTROL (manuelle)
- * Frame for the 3rd manoeuvre position - HYDROCONTROL (manual)
- * Bastidor 3er punto de maniobra - HYDROCONTROL (manual)

TAV. GI.04.01

matr. G107.0005

21
23 P

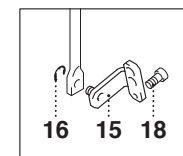
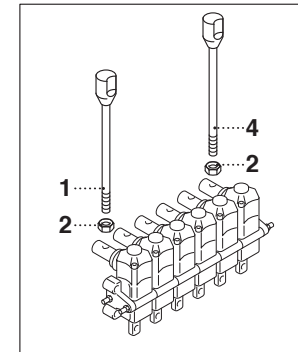
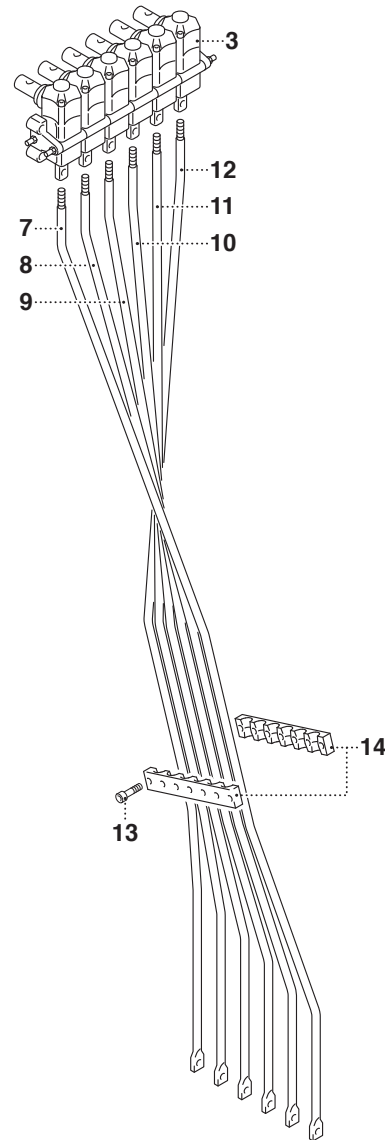
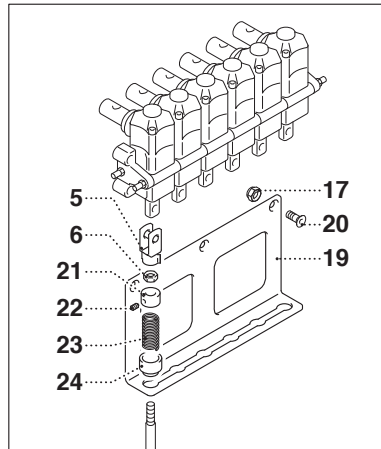

PM 21 - PM 23 P

matr. G107.0005

TAV. GI.04.01

POS.	N° CODICE	Q.	DESCRIZIONE	DESIGNATION	BENENNUNG	DESCRIPTION	DENOMINACIONES
1	120635	5	LEVA	LEVIER	HEBEL	LEVER	PALANCA
2	191064	6	DADO	ECROU	MUTTER	NUT	TUERCA
3	494504	1	DISTRIBUTORE - 6 ELEMENTI	DISTRIBUTEUR - 6 ELEM.	STEUERVENTIL - 6 ELEM.	CONTROL VALVE B. - 6 ELEM.	DISTRIBUIDOR - 6 ELEM.
4	120634	1	LEVA	LEVIER	HEBEL	LEVER	PALANCA
5	220018	6	FORCELLA	FOURCHE	GABEL	CLEVIS	HORQUILLA
6	191063	6	DADO	ECROU	MUTTER	NUT	TUERCA
7	481363	1	TIRANTE - 2A ATTIVAZIONE	TIRANT - 2E ACTIVATION	ZUGSTANGE - 2.BETATIGUNG	TIE ROD - 2ND ACTIVATION	TIRANTE - 2DA ACTIVAC.
8	481362	1	TIRANTE - 1A ATTIVAZIONE	TIRANT - 1E ACTIVATION	ZUGSTANGE - 1.BETATIGUNG	TIE ROD - 1ST ACTIVATION	TIRANTE - 1ERA ACTIVAC.
9	497221	1	TIRANTE SFILO	TIRANT EXTENSION	AUSZIEHENZUGSTANGE	EXTENSION TIE ROD	TIRANTE EXTENSION
10	481361	1	TIRANTE BRACCIO PRINCIPALE	TIRANT BRAS PRINCIPAL	HAUPTARMZUGSTANGE	MAIN ARM TIE ROD	TIRANTE BRAZO PRINCIPAL
11	481360	1	TIRANTE COLONNA	TIRANT COLONNE	SÄULEZUGSTANGE	COLUMN TIE ROD	TIRANTE COLUMNNA
12	481359	1	TIRANTE ROTAZIONE	TIRANT ROTATION	SCHWENKZUGSTANGE	ROTATION TIE ROD	TIRANTE ROTACION
13	497120	4	VITE	VIS	SCHRAUBE	SCREW	TORNILLO
14	466632	2	SUPPORTO	SUPPORT	TRÄGER	SUPPORT	SOPORTE
15	497447	6	SUPPORTO	SUPPORT	TRÄGER	SUPPORT	SOPORTE
16	109139	6	ANELLO ELASTICO	JOINT D'ARRET	SPRENGRING	SPRING RING	ANILLO ELASTICO
17	191125	3	DADO	ECROU	MUTTER	NUT	TUERCA
18	497287	6	VITE	VIS	SCHRAUBE	SCREW	TORNILLO
19	467868	1	SUPPORTO	SUPPORT	TRÄGER	SUPPORT	SOPORTE
20	497886	3	VITE	VIS	SCHRAUBE	SCREW	TORNILLO
21	136925	6	BOCCOLA	DOUILLE	BUCHSE	BUSHING	CASQUILLO
22	497283	6	VITE	VIS	SCHRAUBE	SCREW	TORNILLO
23	349110	6	MOLLA	RESSORT	FEDER	SPRING	MUELLE
24	136912	6	BOCCOLA	DOUILLE	BUCHSE	BUSHING	CASQUILLO



MANDATA E SCARICO - HYDROCONTROL (21)

- * Conduit en pression et retour - HYDROCONTROL
- * Ausgus- und Auslaufschläuche - HYDROCONTROL
- * Delivery and return - HYDROCONTROL
- * Latiquillos de retorno - HYDROCONTROL

TAV. GJ.01.01

matr. G107.0005

21
23 P

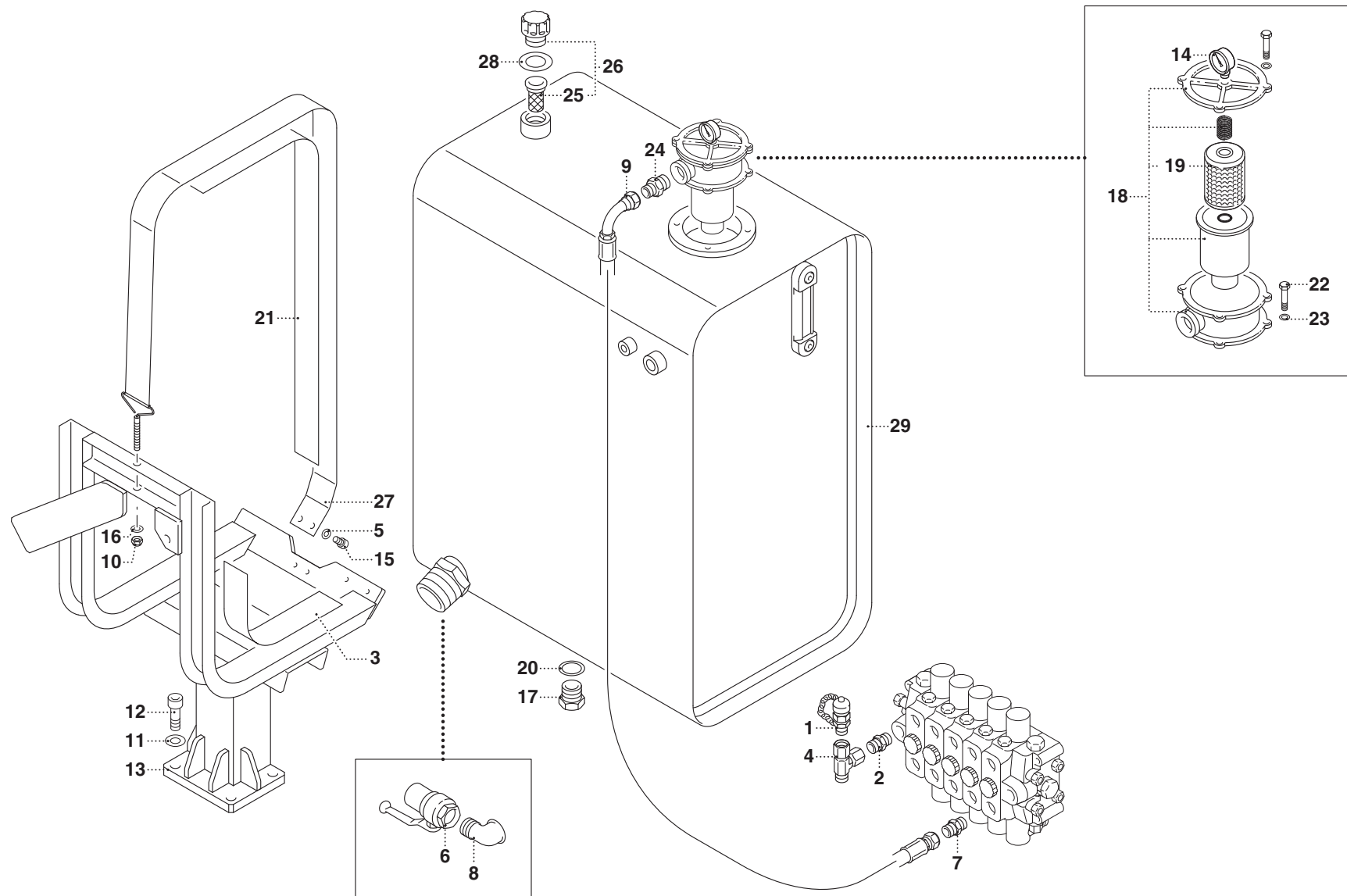

PM 21

matr. G107.0005

TAV. GJ.01.01

POS.	N° CODICE	Q.	DESCRIZIONE	DESIGNATION	BENENNUNG	DESCRIPTION	DENOMINACIONES
1	124009	1	INNESTO RAPIDO	CONNECTION RAPIDE	SCHNELLKUPPLUNG	FAST COUPLING	CONEXION RAPIDA
2	409586	1	RACCORDO	RACCORD	ANSCHLUSS	FITTING	RACOR
3	262019	2	SPESSORE	EPAISSEUR	DICKE	THICKNESS	ESPEJOR
4	409590	1	RACCORDO	RACCORD	ANSCHLUSS	FITTING	RACOR
5	417025	2	RONDELLA	RONDELLE	SCHEIBE	WASHER	ARANDELA
6	421020	1	RUBINETTO	ROBINET	HAHN	COCK	GRIFO
7	409173	1	RACCORDO	RACCORD	ANSCHLUSS	FITTING	RACOR
8	185005	1	RACCORDO	RACCORD	ANSCHLUSS	FITTING	RACOR
9	482364	1	TUBO FLESSIBILE	TUYAU FLEXIBLE	SCHLAUCH	FLEXIBLE HOSE	TUBO FLEXIBLE
10	191045	1	DADO	ECROU	MUTTER	NUT	TUERCA
11	417028	4	RONDELLA	RONDELLE	SCHEIBE	WASHER	ARANDELA
12	497175	4	VITE	VIS	SCHRAUBE	SCREW	TORNILLO
13	466450	1	SUPPORTO	SUPPORT	TRÄGER	SUPPORT	SOPORTE
14	335010	1	MANOMETRO	MANOMETRE	DRUCKMESSER	GAUGE	MANOMETRO
15	497130	2	VITE	VIS	SCHRAUBE	SCREW	TORNILLO
16	417005	1	RONDELLA	RONDELLE	SCHEIBE	WASHER	ARANDELA
17	471029	1	TAPPO	BOUCHON	VERSCHLUSSDECKEL	PLUG	TAPON
18	215076	1	FILTRO	FILTRE	FILTER	FILTER	FILTRO
19	149065	1	CARTUCCIA FILTRANTE	CARTOUCHE FILTRANTE	FILTEREINSATZ	FILTERING CARTRIDGE	CARTUCHO FILTRANTE
20	417087	1	RONDELLA	RONDELLE	SCHEIBE	WASHER	ARANDELA
21	232158	1	GUARNIZIONE	JOINT	DICHTUNG	SEAL	GUARNICION
22	497036	2	VITE	VIS	SCHRAUBE	SCREW	TORNILLO
23	417016	2	RONDELLA	RONDELLE	SCHEIBE	WASHER	ARANDELA
24	409425	1	RACCORDO	RACCORD	ANSCHLUSS	FITTING	RACOR
25	149071	1	CARTUCCIA FILTRANTE	CARTOUCHE FILTRANTE	FILTEREINSATZ	FILTERING CARTRIDGE	CARTUCHO FILTRANTE
26	215075	1	FILTRO	FILTRE	FILTER	FILTER	FILTRO



MANDATA E SCARICO - HYDROCONTROL (21)

- * Conduit en pression et retour - HYDROCONTROL
- * Ausgus- und Auslaufschläuche - HYDROCONTROL
- * Delivery and return - HYDROCONTROL
- * Latiquillos de retorno - HYDROCONTROL

TAV. GJ.01.01

matr. G107.0005

21
23 P

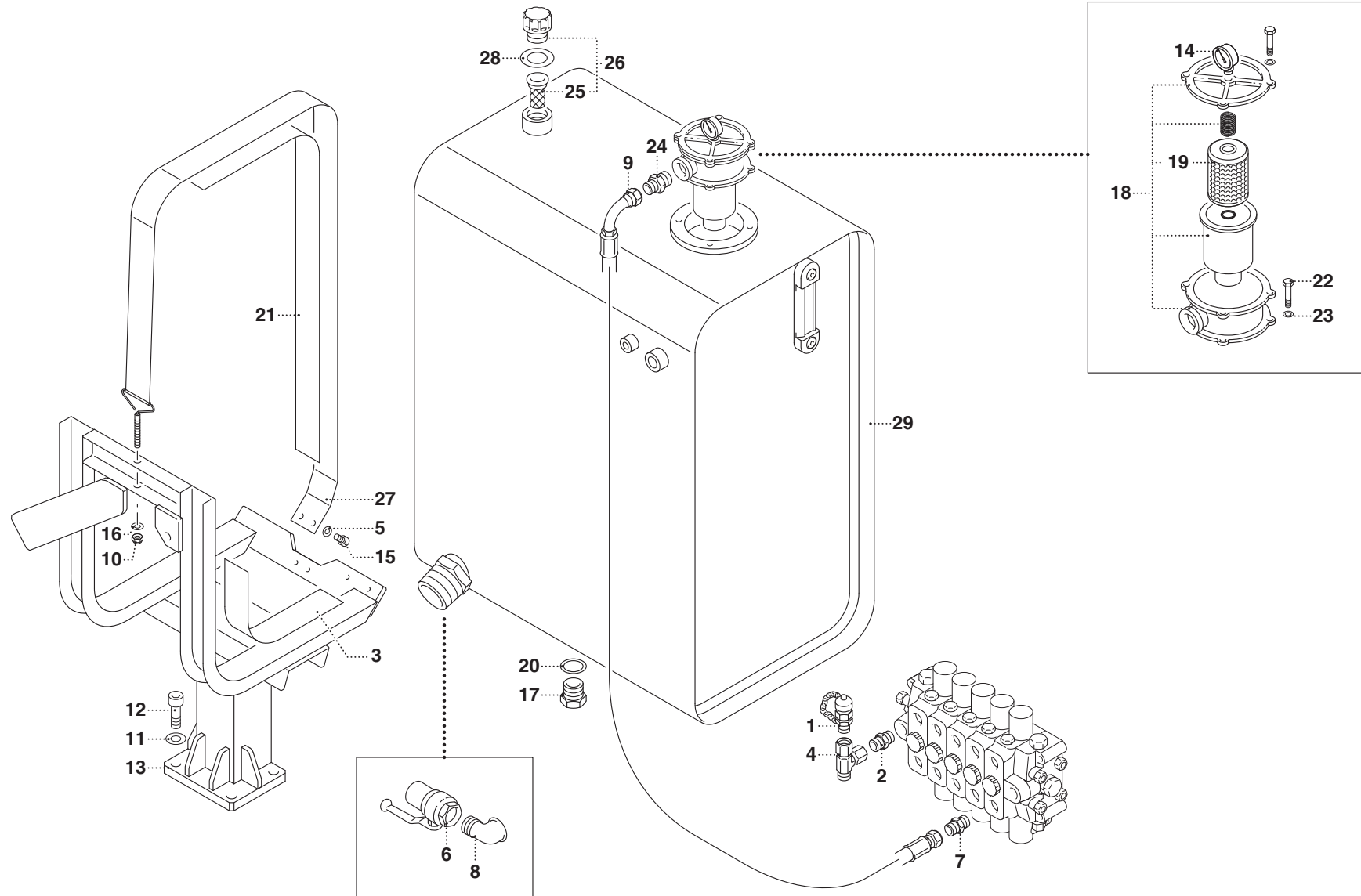



MANDATA E SCARICO - DANFOSS

* Conduit en pression et retour - DANFOSS

* Ausgus- und Auslaufschläuche - DANFOSS

* Delivery and return - DANFOSS

* Latiguillos de retorno - DANFOSS

TAV. GJ.01.02

matr. G107.0005

21
23 P

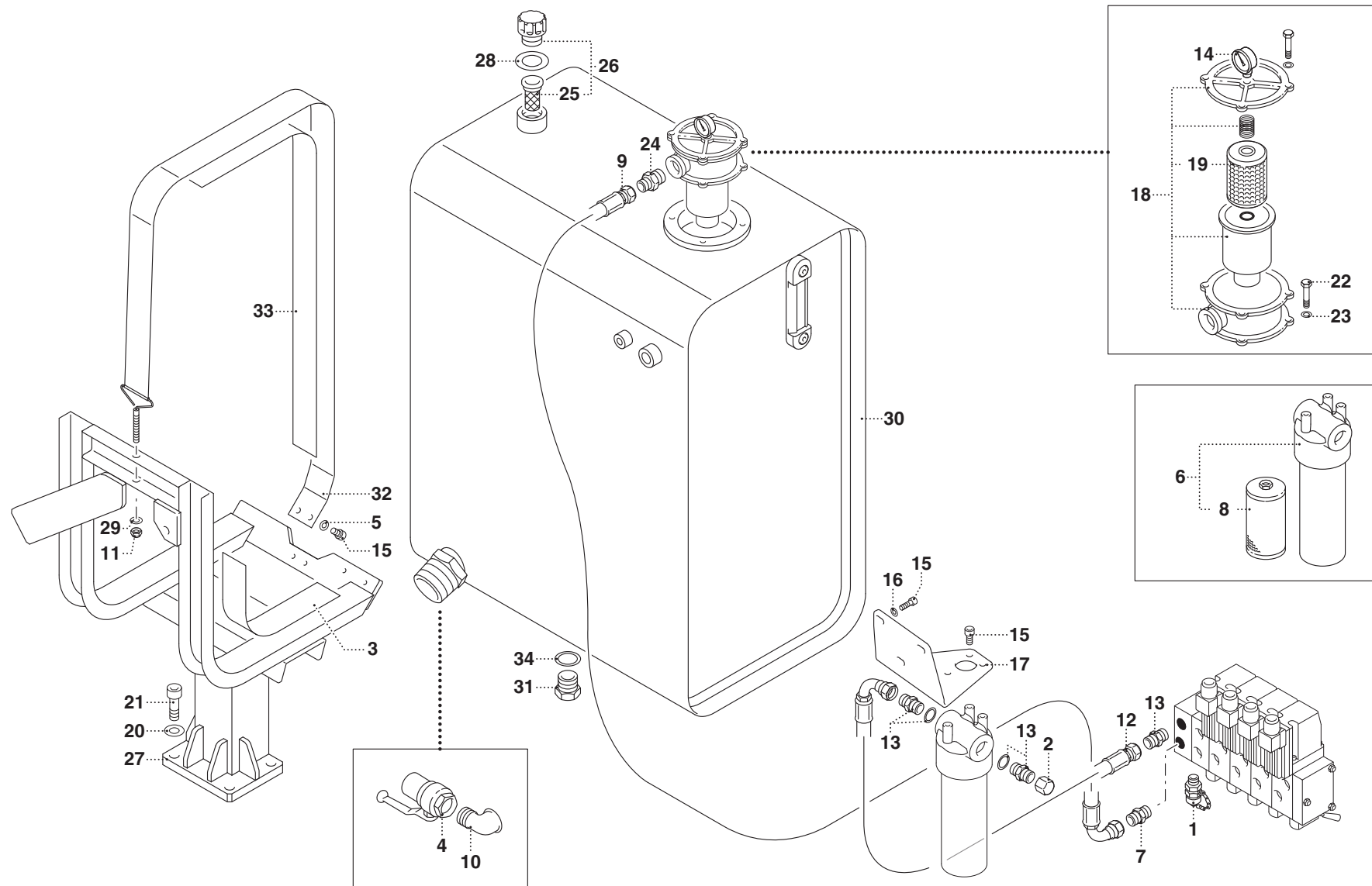

PM 21 - PM 23 P

matr. G107.0005

TAV. GJ.01.02

POS.	N° CODICE	Q.	DESCRIZIONE	DESIGNATION	BENENNUNG	DESCRIPTION	DENOMINACIONES
1	124009	1	INNESTO RAPIDO	CONNECTION RAPIDE	SCHNELLKUPPLUNG	FAST COUPLING	CONEXION RAPIDA
2	471130	1	TAPPO	BOUCHON	VERSCHLUSSDECKEL	PLUG	TAPON
3	262019	2	SPESSORE	EPAISSEUR	DICKE	THICKNESS	ESPEJOR
4	421020	1	RUBINETTO	ROBINET	HAHN	COCK	GRIFO
5	417025	2	RONDELLA	RONDELLE	SCHEIBE	WASHER	ARANDELA
6	215073	1	FILTRO	FILTRE	FILTER	FILTER	FILTRO
7	409173	1	RACCORDO	RACCORD	ANSCHLUSS	FITTING	RACOR
8	149070	1	CARTUCCIA FILTRANTE	CARTOUCHE FILTRANTE	FILTEREINSATZ	FILTERING CARTRIDGE	CARTUCHO FILTRANTE
9	482364	1	TUBO FLESSIBILE	TUYAU FLEXIBLE	SCHLAUCH	FLEXIBLE HOSE	TUBO FLEXIBLE
10	185005	1	RACCORDO	RACCORD	ANSCHLUSS	FITTING	RACOR
11	191045	1	DADO	ECROU	MUTTER	NUT	TUERCA
12	482482	1	TUBO FLESSIBILE	TUYAU FLEXIBLE	SCHLAUCH	FLEXIBLE HOSE	TUBO FLEXIBLE
13	409637	3	RACCORDO	RACCORD	ANSCHLUSS	FITTING	RACOR
14	335010	1	MANOMETRO	MANOMETRE	DRUCKMESSER	GAUGE	MANOMETRO
15	497130	8	VITE	VIS	SCHRAUBE	SCREW	TORNILLO
16	417004	3	RONDELLA	RONDELLE	SCHEIBE	WASHER	ARANDELA
17	467510	1	SUPPORTO	SUPPORT	TRÄGER	SUPPORT	SOPORTE
18	215076	1	FILTRO	FILTRE	FILTER	FILTER	FILTRO
19	149065	1	CARTUCCIA FILTRANTE	CARTOUCHE FILTRANTE	FILTEREINSATZ	FILTERING CARTRIDGE	CARTUCHO FILTRANTE
20	417087	4	RONDELLA	RONDELLE	SCHEIBE	WASHER	ARANDELA
21	497175	4	VITE	VIS	SCHRAUBE	SCREW	TORNILLO
22	497036	2	VITE	VIS	SCHRAUBE	SCREW	TORNILLO
23	417016	2	RONDELLA	RONDELLE	SCHEIBE	WASHER	ARANDELA
24	409425	1	RACCORDO	RACCORD	ANSCHLUSS	FITTING	RACOR
25	149071	1	CARTUCCIA FILTRANTE	CARTOUCHE FILTRANTE	FILTEREINSATZ	FILTERING CARTRIDGE	CARTUCHO FILTRANTE
26	215075	1	FILTRO	FILTRE	FILTER	FILTER	FILTRO



MANDATA E SCARICO - DANFOSS

* Conduit en pression et retour - DANFOSS
* Ausgus- und Auslaufschläuche - DANFOSS
* Delivery and return - DANFOSS
* Latiguillos de retorno - DANFOSS

TAV. GJ.01.02

matr. G107.0005

21
23 P

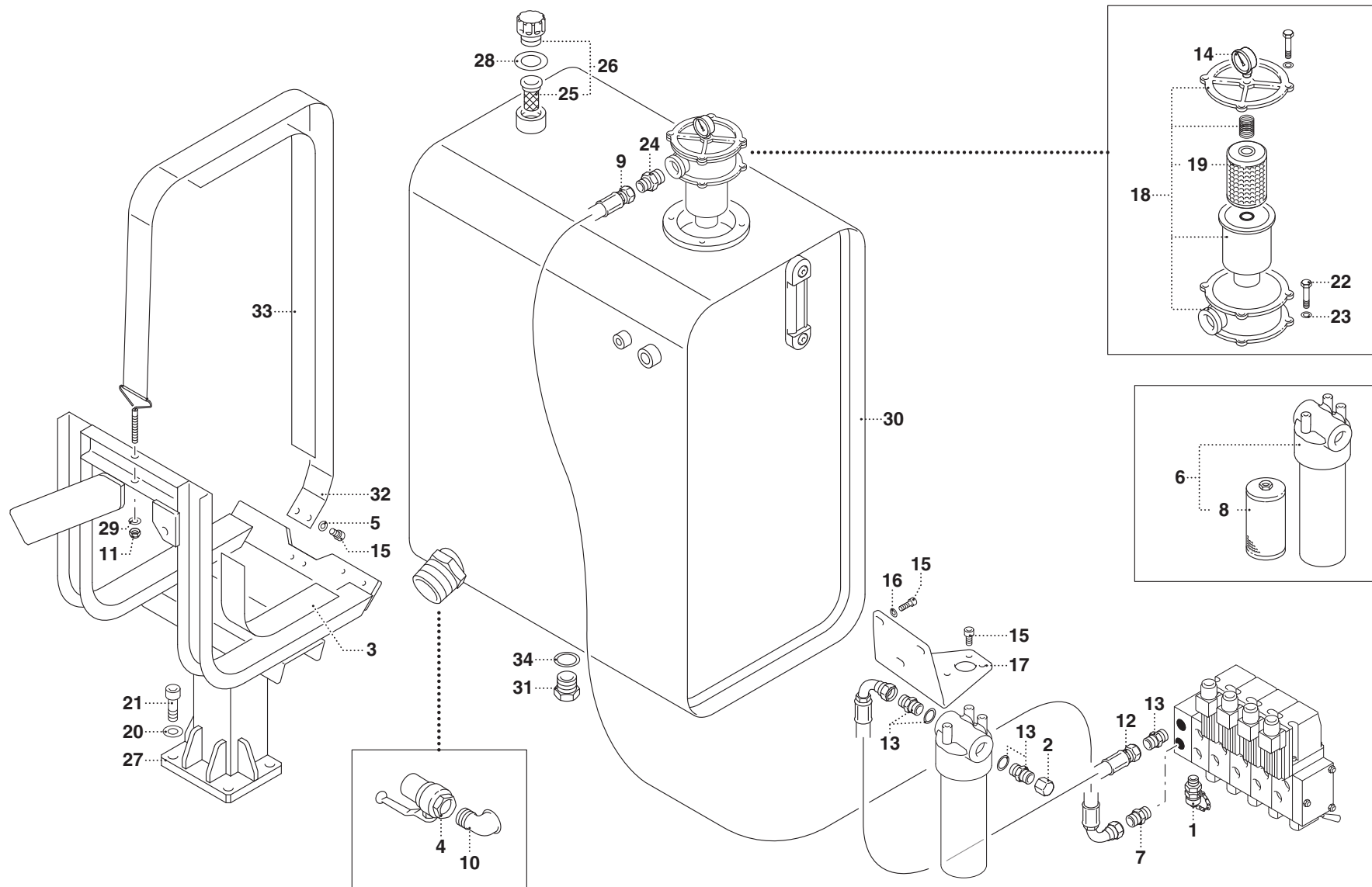

PM 21 - PM 23 P

matr. G107.0005

TAV. GJ.01.02

POS.	N° CODICE	Q.	DESCRIZIONE	DESIGNATION	BENENNUNG	DESCRIPTION	DENOMINACIONES
27	466450	1	SUPPORTO	SUPPORT	TRÄGER	SUPPORT	SOPORTE
28	417088	1	RONDELLA	RONDELLE	SCHEIBE	WASHER	ARANDELA
29	417005	1	RONDELLA	RONDELLE	SCHEIBE	WASHER	ARANDELA
30	443087	1	SERBATOIO	RESERVOIR	TANK	TANK	DEPOSITO
31	471029	1	TAPPO	BOUCHON	VERSCHLUSSDECKEL	PLUG	TAPON
32	207091	1	FASCETTA	COLLIER	HALTEBAND	CLAMP	ABRAZADERA
33	262158	1	GUARNIZIONE	JOINT	DICHTUNG	SEAL	GUARNICION
34	417087	1	RONDELLA	RONDELLE	SCHEIBE	WASHER	ARANDELA



IMPIANTO IDRAULICO COLLEGAMENTO DISTRIBUTORE (HYDROCONTROL-RADIOCOMANDO) (21)

- * Installation hydraulique jonction distributeur (Hydrocontrol-radiocommande)
- * Steuerventilverbindung-Hydraulischeanlage (Hydrocontrol-Funksteuerung)
- * Control valve block connection hydraulic system (Hydrocontro-Radio control)
- * Instalación neumática conexión distribuidor (Hydrocontrol-Radiocontrol)

TAV. GJ.02.01

matr. G107.0005

21
23 P

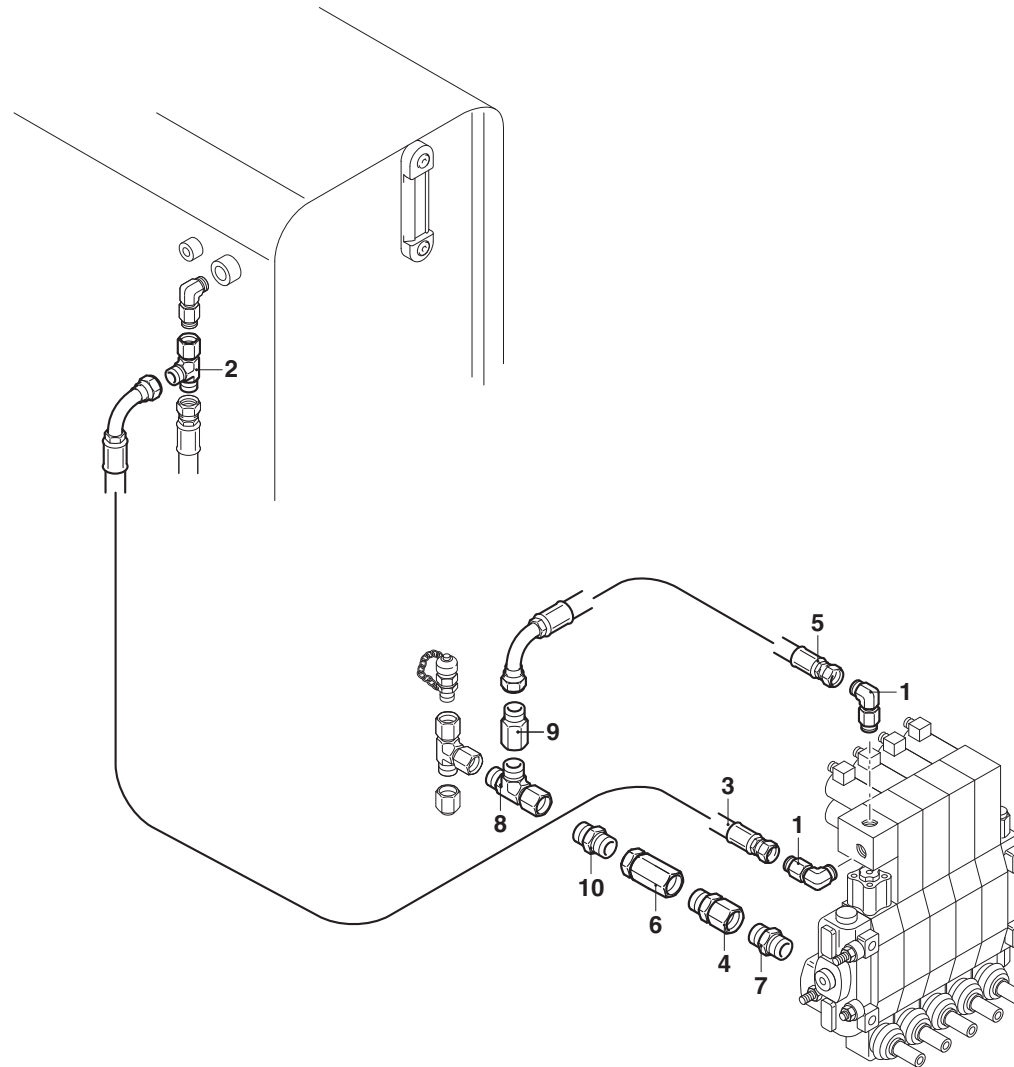

PM 21**matr. G107.0005****TAV. GJ.02.01**

POS.	N° CODICE	Q.	DESCRIZIONE	DESIGNATION	BENENNUNG	DESCRIPTION	DENOMINACIONES
1	409619	2	RACCORDO	RACCORD	ANSCHLUSS	FITTING	RACOR
2	409599	1	RACCORDO	RACCORD	ANSCHLUSS	FITTING	RACOR
3	486582	1	TUBO FLESSIBILE	TUYAU FLEXIBLE	SCHLAUCH	FLEXIBLE HOSE	TUBO FLEXIBLE
4	409427	1	RACCORDO	RACCORD	ANSCHLUSS	FITTING	RACOR
5	485964	1	TUBO FLESSIBILE	TUYAU FLEXIBLE	SCHLAUCH	FLEXIBLE HOSE	TUBO FLEXIBLE
6	495634	1	VALVOLA	SOUPAPE	VENTIL	VALVE	VALVULA
7	409831	1	RACCORDO	RACCORD	ANSCHLUSS	FITTING	RACOR
8	409390	1	RACCORDO	RACCORD	ANSCHLUSS	FITTING	RACOR
9	409525	1	RACCORDO	RACCORD	ANSCHLUSS	FITTING	RACOR
10	409586	1	RACCORDO	RACCORD	ANSCHLUSS	FITTING	RACOR



IMPIANTO IDRAULICO COLLEGAMENTO DISTRIBUTORE (HYDROCONTROL-RADIOCOMANDO) (21)

- * Installation hydraulique jonction distributeur (Hydrocontrol-radiocommande)
- * Steuerventilverbindung-Hydraulischeanlage (Hydrocontrol-Funksteuerung)
- * Control valve block connection hydraulic system (Hydrocontro-Radio control)
- * Instalación neumática conexión distribuidor (Hydrocontrol-Radiocontrol)

TAV. GJ.02.02

matr. G107.0005

21
23 P

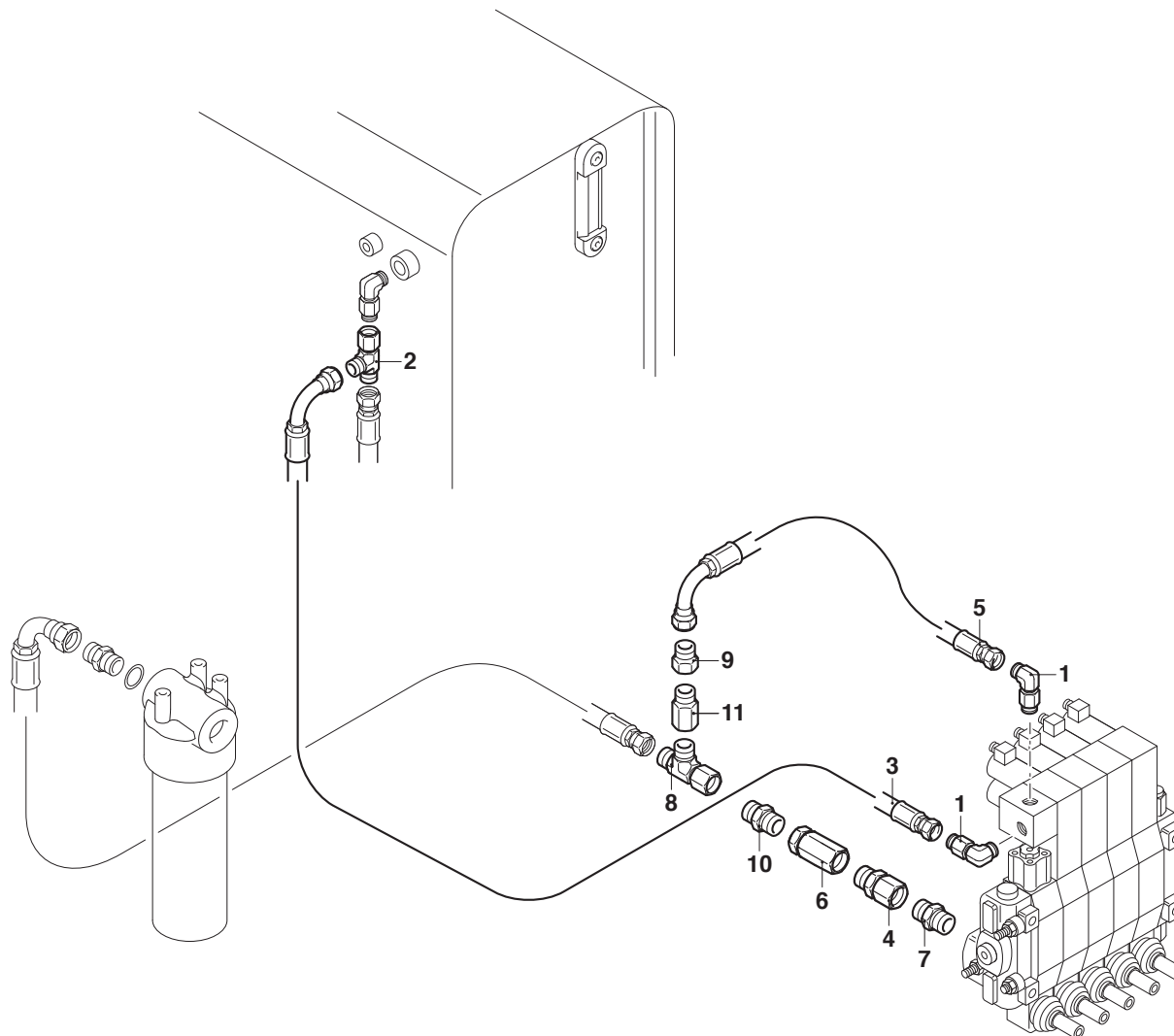



DISTRIBUTORE BRACCI STABILIZZATORI HYDROCONTROL - DANFOSS (21)

* Distributeur bras stabilisateurs HYDROCONTROL - DANFOSS

* HYDROCONTROL Stützarme Steuerventil - DANFOSS

* HYDROCONTROL outrigger arms control valve - DANFOSS

* Distribuidor brazos estabilizadores HYDROCONTROL - DANFOSS

TAV. GJ.03.01

matr. G107.0005

21
23 P

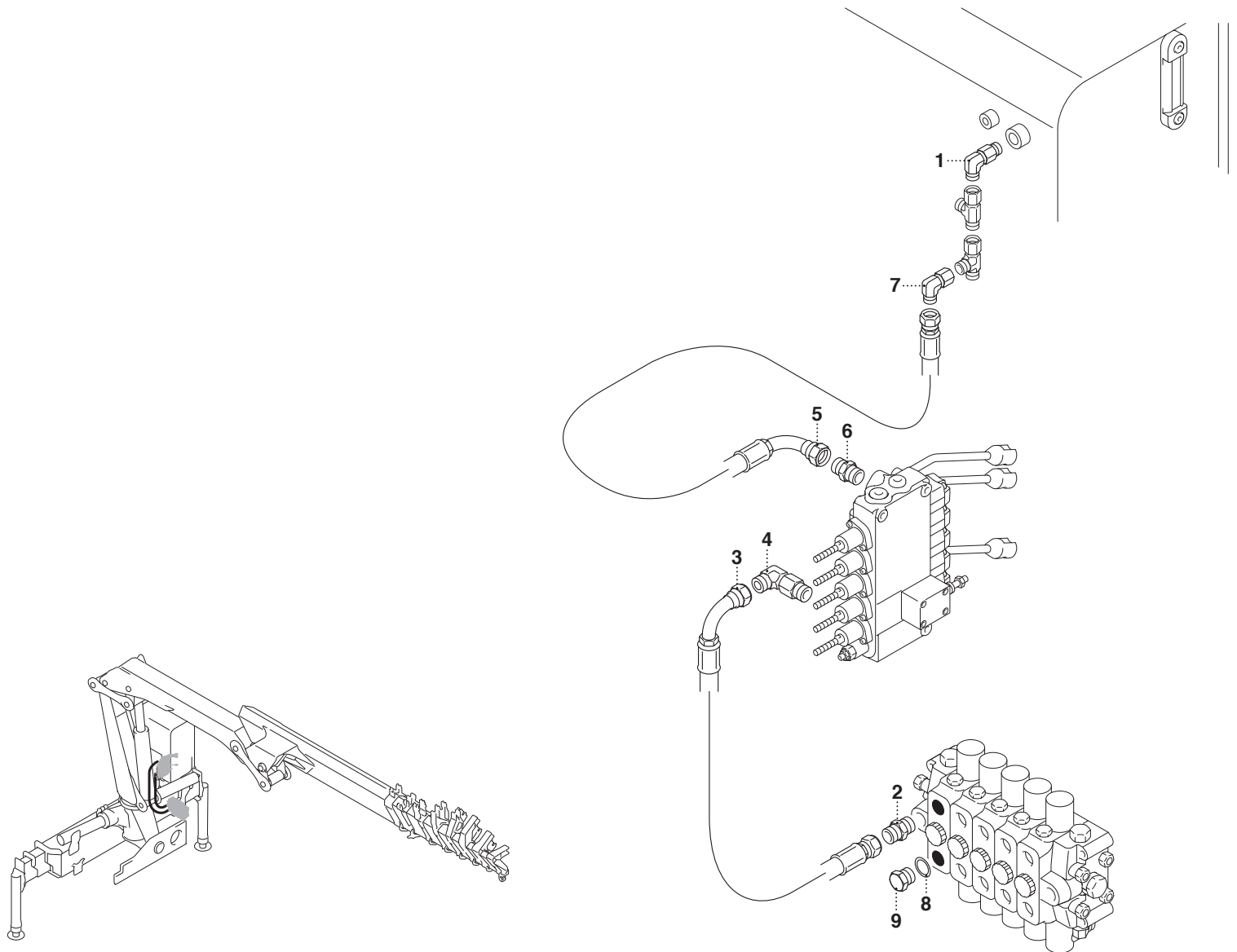

PM 21**matr. G107.0005****TAV. GJ.03.01**

POS.	N° CODICE	Q.	DESCRIZIONE	DESIGNATION	BENENNUNG	DESCRIPTION	DENOMINACIONES
1	409595	1	RACCORDO	RACCORD	ANSCHLUSS	FITTING	RACOR
2	409632	1	RACCORDO	RACCORD	ANSCHLUSS	FITTING	RACOR
3	482358	1	TUBO FLESSIBILE	TUYAU FLEXIBLE	SCHLAUCH	FLEXIBLE HOSE	TUBO FLEXIBLE
4	409601	1	RACCORDO	RACCORD	ANSCHLUSS	FITTING	RACOR
5	486734	1	TUBO FLESSIBILE	TUYAU FLEXIBLE	SCHLAUCH	FLEXIBLE HOSE	TUBO FLEXIBLE
6	409831	1	RACCORDO	RACCORD	ANSCHLUSS	FITTING	RACOR
7	409597	1	RACCORDO	RACCORD	ANSCHLUSS	FITTING	RACOR
8	417092	1	RONDELLA	RONDELLE	SCHEIBE	WASHER	ARANDELA
9	471026	1	TAPPO	BOUCHON	VERSCHLUSSDECKEL	PLUG	TAPON



DISTRIBUTORE BRACCI STABILIZZATORI DANFOSS SENZA "MCS"

- * Distributeur bras stabilisateurs DANFOSS sans "MCS"
- * DANFOSS Stützarme Steuerventil ohne "MCS"
- * DANFOSS outrigger arms control valve without "MCS"
- * Distribuidor brazos estabilizadores DANFOSS sin "MCS"

TAV. GJ.03.02

matr. G107.0005

21
23 P

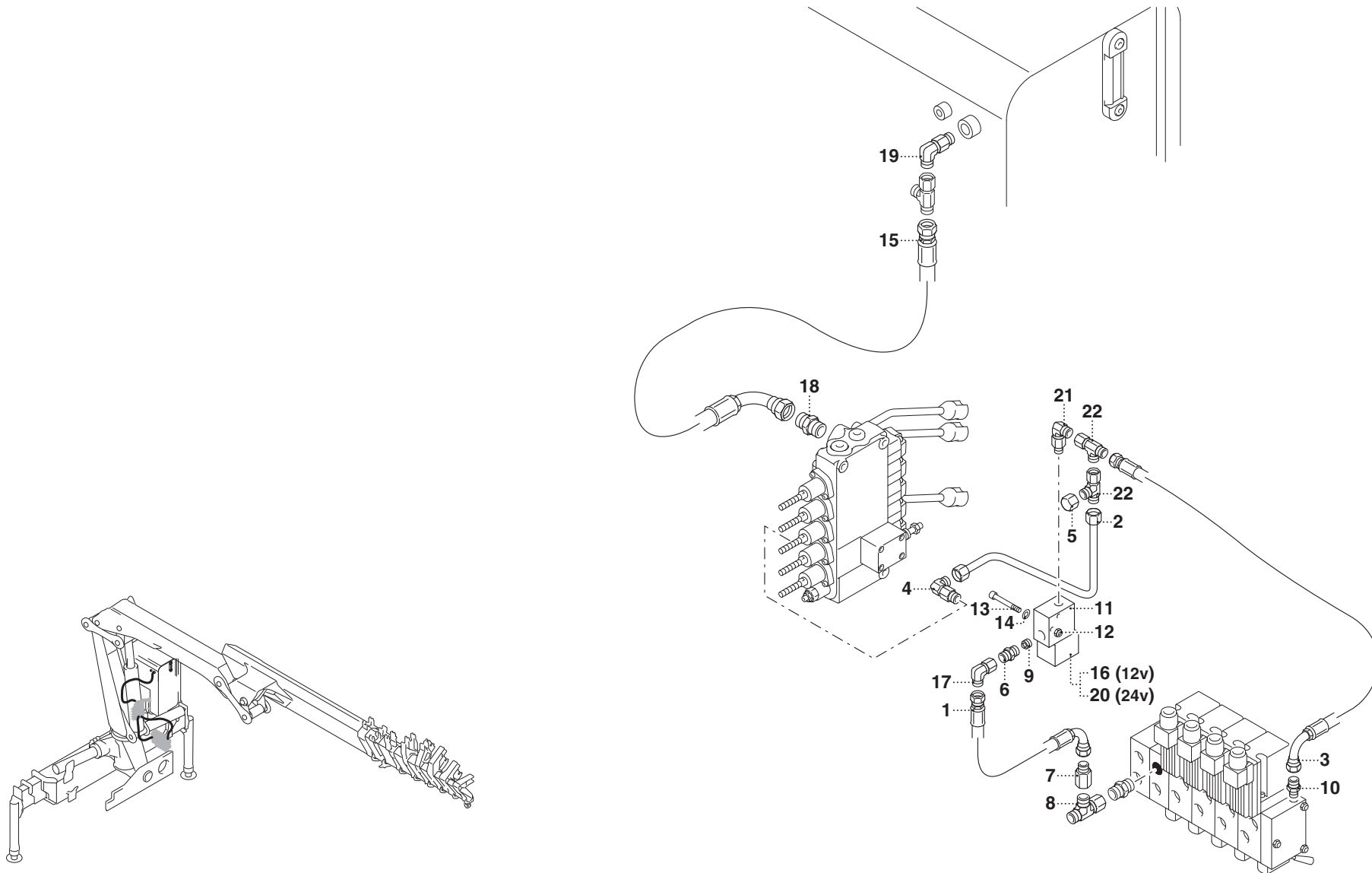

UN01-R-1628-CH

PM 21 - PM 23 P**matr. G107.0005****TAV. GJ.03.02**

POS.	N° CODICE	Q.	DESCRIZIONE	DESIGNATION	BENENNUNG	DESCRIPTION	DENOMINACIONES
1	482361	1	TUBO FLESSIBILE	TUYAU FLEXIBLE	SCHLAUCH	FLEXIBLE HOSE	TUBO FLEXIBLE
2	460265	1	TUBO RIGIDO	TUYAU RIGIDE	ROHR	PIPE	TUBO RIGIDO
3	486070	1	TUBO FLESSIBILE	TUYAU FLEXIBLE	SCHLAUCH	FLEXIBLE HOSE	TUBO FLEXIBLE
4	409867	1	RACCORDO	RACCORD	ANSCHLUSS	FITTING	RACOR
5	471158	1	TAPPO	BOUCHON	VERSCHLUSSDECKEL	PLUG	TAPON
6	409634	1	RACCORDO	RACCORD	ANSCHLUSS	FITTING	RACOR
7	409155	1	RACCORDO	RACCORD	ANSCHLUSS	FITTING	RACOR
8	409649	1	RACCORDO	RACCORD	ANSCHLUSS	FITTING	RACOR
9	495635	1	VALVOLA	SOUPAPE	VENTIL	VALVE	VALVULA
10	410077	1	RACCORDO	RACCORD	ANSCHLUSS	FITTING	RACOR
11	204088	1	BLOCCHETTO	BLOC	BLOCK	BLOCK	BLOQUETE
12	191062	2	DADO	ECROU	MUTTER	NUT	TUERCA
13	497125	2	VITE	VIS	SCHRAUBE	SCREW	TORNILLO
14	417003	2	RONDELLA	RONDELLE	SCHEIBE	WASHER	ARANDELA
15	486734	1	TUBO FLESSIBILE	TUYAU FLEXIBLE	SCHLAUCH	FLEXIBLE HOSE	TUBO FLEXIBLE
16	395379	1	BOBINA	BOBINE	SPULE	COIL	BOBINA
17	409633	1	RACCORDO	RACCORD	ANSCHLUSS	FITTING	RACOR
18	409831	1	RACCORDO	RACCORD	ANSCHLUSS	FITTING	RACOR
19	409595	1	RACCORDO	RACCORD	ANSCHLUSS	FITTING	RACOR
20	395380	1	BOBINA	BOBINE	SPULE	COIL	BOBINA
21	409865	1	RACCORDO	RACCORD	ANSCHLUSS	FITTING	RACOR
22	409907	2	RACCORDO	RACCORD	ANSCHLUSS	FITTING	RACOR

PM 23 P

matr. G107.0005

TAV. GJ.03.03

POS.	N° CODICE	Q.	DESCRIZIONE	DESIGNATION	BENENNUNG	DESCRIPTION	DENOMINACIONES
1	482361	1	TUBO FLESSIBILE	TUYAU FLEXIBLE	SCHLAUCH	FLEXIBLE HOSE	TUBO FLEXIBLE
2	460265	1	TUBO RIGIDO	TUYAU RIGIDE	ROHR	PIPE	TUBO RIGIDO
3	486070	1	TUBO FLESSIBILE	TUYAU FLEXIBLE	SCHLAUCH	FLEXIBLE HOSE	TUBO FLEXIBLE
4	409867	2	RACCORDO	RACCORD	ANSCHLUSS	FITTING	RACOR
5	191064	5	DADO	ECROU	MUTTER	NUT	TUERCA
6	409634	1	RACCORDO	RACCORD	ANSCHLUSS	FITTING	RACOR
7	409155	1	RACCORDO	RACCORD	ANSCHLUSS	FITTING	RACOR
8	409649	1	RACCORDO	RACCORD	ANSCHLUSS	FITTING	RACOR
9	495635	1	VALVOLA	SOUPAPE	VENTIL	VALVE	VALVULA
10	410077	2	RACCORDO	RACCORD	ANSCHLUSS	FITTING	RACOR
11	204088	1	BLOCCHETTO	BLOC	BLOCK	BLOCK	BLOQUETE
12	191062	2	DADO	ECROU	MUTTER	NUT	TUERCA
13	497125	2	VITE	VIS	SCHRAUBE	SCREW	TORNILLO
14	417003	2	RONDELLA	RONDELLE	SCHEIBE	WASHER	ARANDELA
15	486734	1	TUBO FLESSIBILE	TUYAU FLEXIBLE	SCHLAUCH	FLEXIBLE HOSE	TUBO FLEXIBLE
16	395379	1	BOBINA	BOBINE	SPULE	COIL	BOBINA
17	409633	1	RACCORDO	RACCORD	ANSCHLUSS	FITTING	RACOR
18	409771	1	RACCORDO	RACCORD	ANSCHLUSS	FITTING	RACOR
19	409595	1	RACCORDO	RACCORD	ANSCHLUSS	FITTING	RACOR
20	395380	1	BOBINA	BOBINE	SPULE	COIL	BOBINA
21	409865	2	RACCORDO	RACCORD	ANSCHLUSS	FITTING	RACOR
22	409907	2	RACCORDO	RACCORD	ANSCHLUSS	FITTING	RACOR
23	460266	1	TUBO RIGIDO	TUYAU RIGIDE	ROHR	PIPE	TUBO RIGIDO
24	460267	1	TUBO RIGIDO	TUYAU RIGIDE	ROHR	PIPE	TUBO RIGIDO
25	120997	5	LEVA	LEVIER	HEBEL	LEVER	PALANCA



DISTRIBUTORE BRACCI STABILIZZATORI DANFOSS (23 P)

- * Distributeur bras stabilisateurs DANFOSS
- * DANFOSS Stützarme Steuerventil
- * DANFOSS outrigger arms control valve
- * Distribuidor brazos estabilizadores DANFOSS

TAV. GJ.03.04

matr. G107.0005

21
23 P

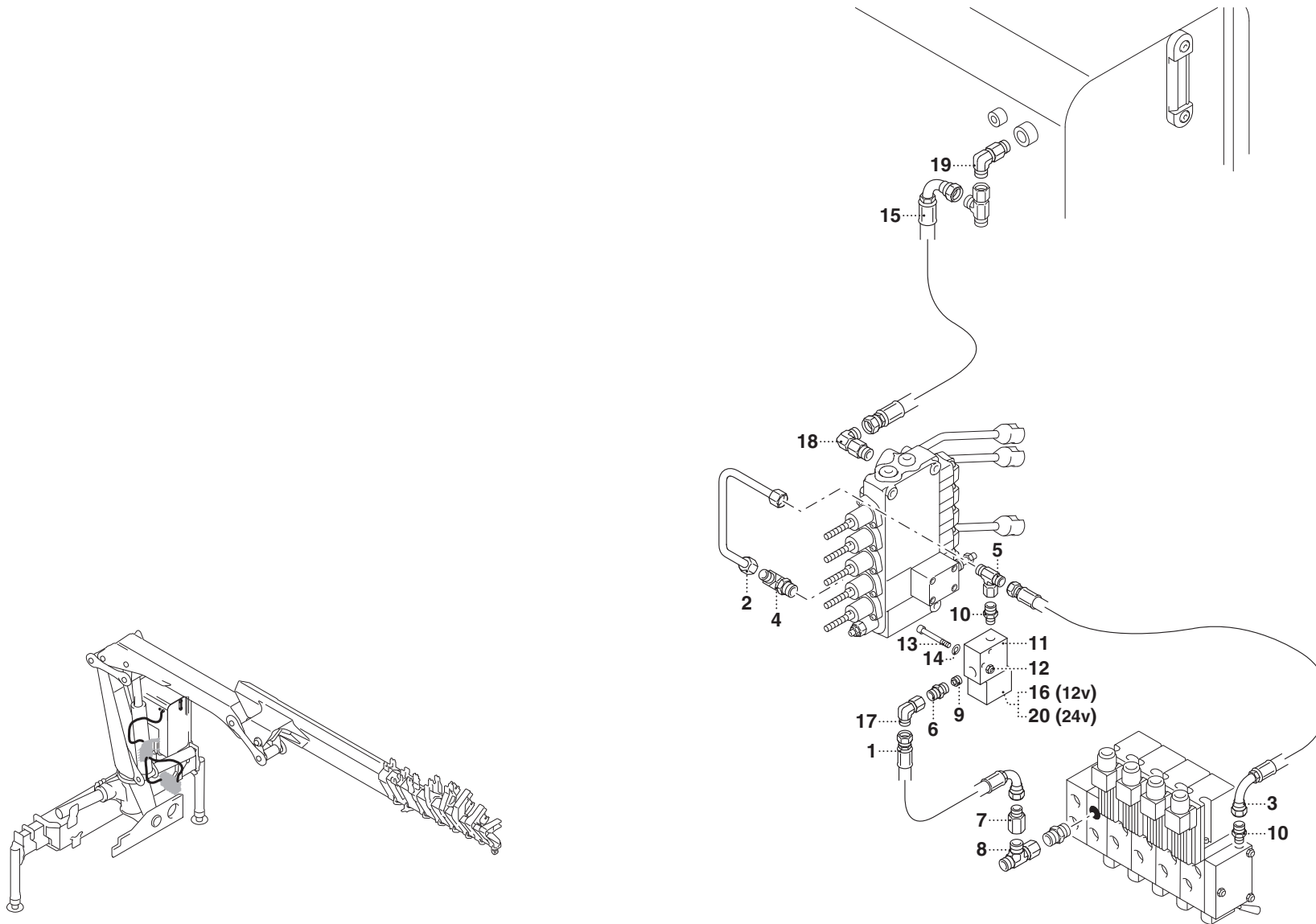

PM 23 P**matr. G107.0005****TAV. GJ.03.04**

POS.	N° CODICE	Q.	DESCRIZIONE	DESIGNATION	BENENNUNG	DESCRIPTION	DENOMINACIONES
1	482361	1	TUBO FLESSIBILE	TUYAU FLEXIBLE	SCHLAUCH	FLEXIBLE HOSE	TUBO FLEXIBLE
2	460229	1	TUBO RIGIDO	TUYAU RIGIDE	ROHR	PIPE	TUBO RIGIDO
3	486070	1	TUBO FLESSIBILE	TUYAU FLEXIBLE	SCHLAUCH	FLEXIBLE HOSE	TUBO FLEXIBLE
4	409867	1	RACCORDO	RACCORD	ANSCHLUSS	FITTING	RACOR
5	409983	1	RACCORDO	RACCORD	ANSCHLUSS	FITTING	RACOR
6	409634	1	RACCORDO	RACCORD	ANSCHLUSS	FITTING	RACOR
7	409155	1	RACCORDO	RACCORD	ANSCHLUSS	FITTING	RACOR
8	409649	1	RACCORDO	RACCORD	ANSCHLUSS	FITTING	RACOR
9	495635	1	VALVOLA	SOUPAPE	VENTIL	VALVE	VALVULA
10	410077	2	RACCORDO	RACCORD	ANSCHLUSS	FITTING	RACOR
11	204088	1	BLOCCHETTO	BLOC	BLOCK	BLOCK	BLOQUETE
12	191062	2	DADO	ECROU	MUTTER	NUT	TUERCA
13	497125	2	VITE	VIS	SCHRAUBE	SCREW	TORNILLO
14	417003	2	RONDELLA	RONDELLE	SCHEIBE	WASHER	ARANDELA
15	486734	1	TUBO FLESSIBILE	TUYAU FLEXIBLE	SCHLAUCH	FLEXIBLE HOSE	TUBO FLEXIBLE
16	395379	1	BOBINA	BOBINE	SPULE	COIL	BOBINA
17	409633	1	RACCORDO	RACCORD	ANSCHLUSS	FITTING	RACOR
18	409771	1	RACCORDO	RACCORD	ANSCHLUSS	FITTING	RACOR
19	409595	1	RACCORDO	RACCORD	ANSCHLUSS	FITTING	RACOR
20	395380	1	BOBINA	BOBINE	SPULE	COIL	BOBINA



COMANDO BRACCI STABILIZZATORI

- * *Commande bras stabilisateurs*
- * *Stützarmsteuerung*
- * *Outrigger arms control*
- * *Mando brazos estabilizadores*

TAV. GK.01.01 1/2

matr. G107.0005

21
23 P

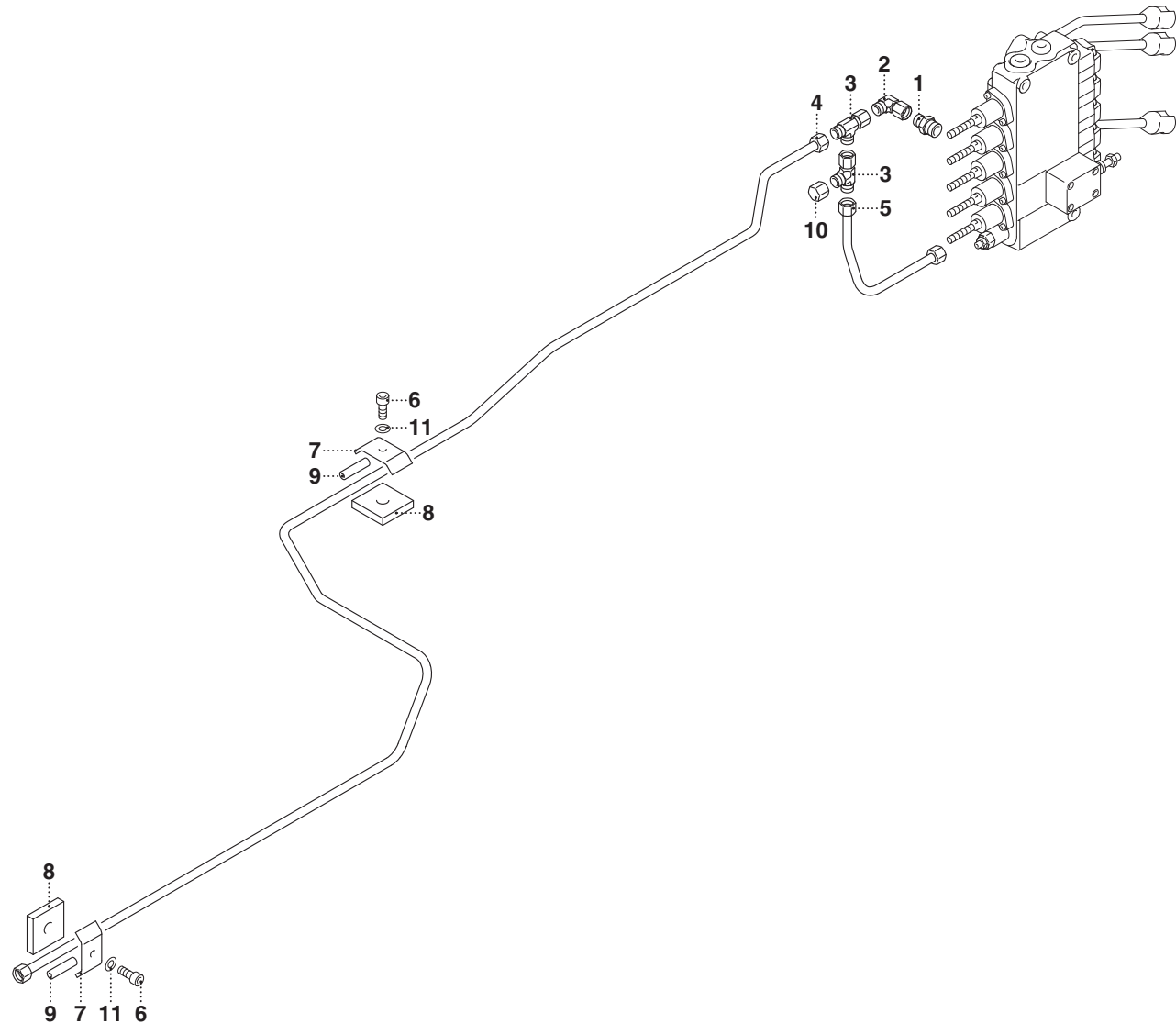
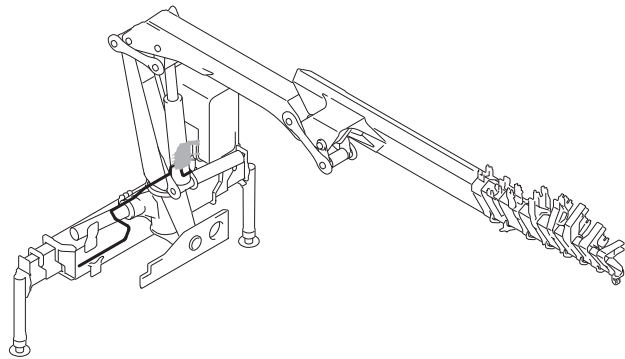



COMANDO BRACCI STABILIZZATORI

- * *Commande bras stabilisateurs*
- * *Stützarmesteuerung*
- * *Outrigger arms control*
- * *Mando brazos estabilizadores*

TAV. GK.01.01 2/2

matr. G107.0005

21
23 P

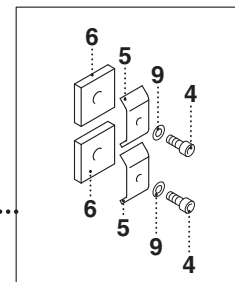
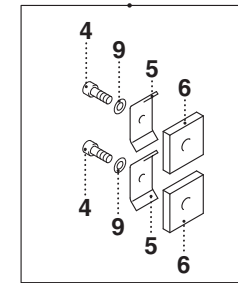
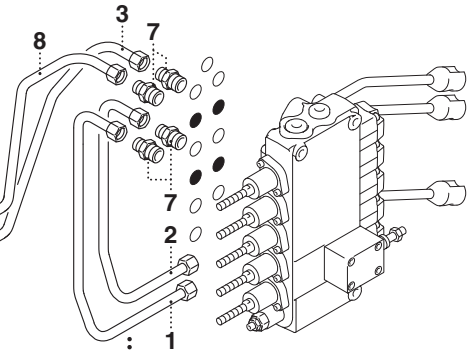
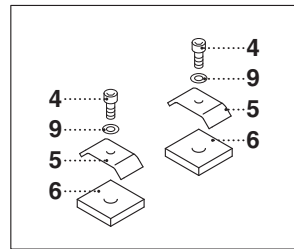
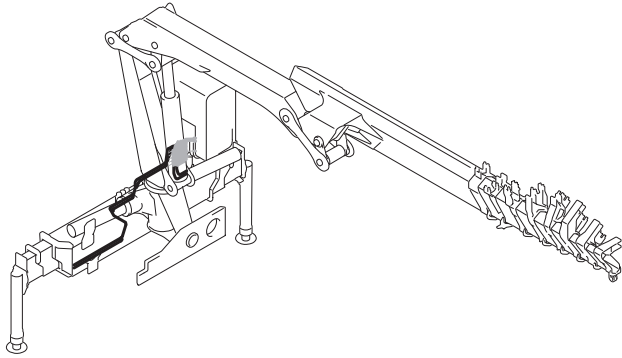



KIT MARTINETTO STABILIZZATORI FISSI - 340434

* Kit vérin stabilisateurs fixes
* Feststützzyllindersatz
* Fixed outriggers cylinders kit
* Kit cilindro estabilizadores fijos

TAV. GK.02.01

matr. G107.0005

21
23 P

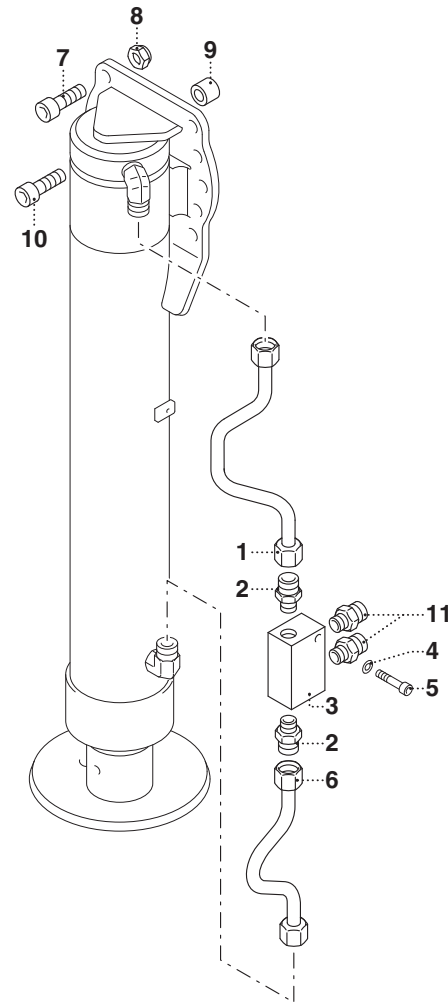



KIT MARTINETTO STABILIZZATORI ROTANTI - 340428

* Kit vérin stabilisateurs tournants
* Drehstützzylindersatz
* Rotating outriggers cylinders kit
* Kit cilindro estabilizadores rotatorios

TAV. GK.02.02

matr. G107.0005

21
23 P

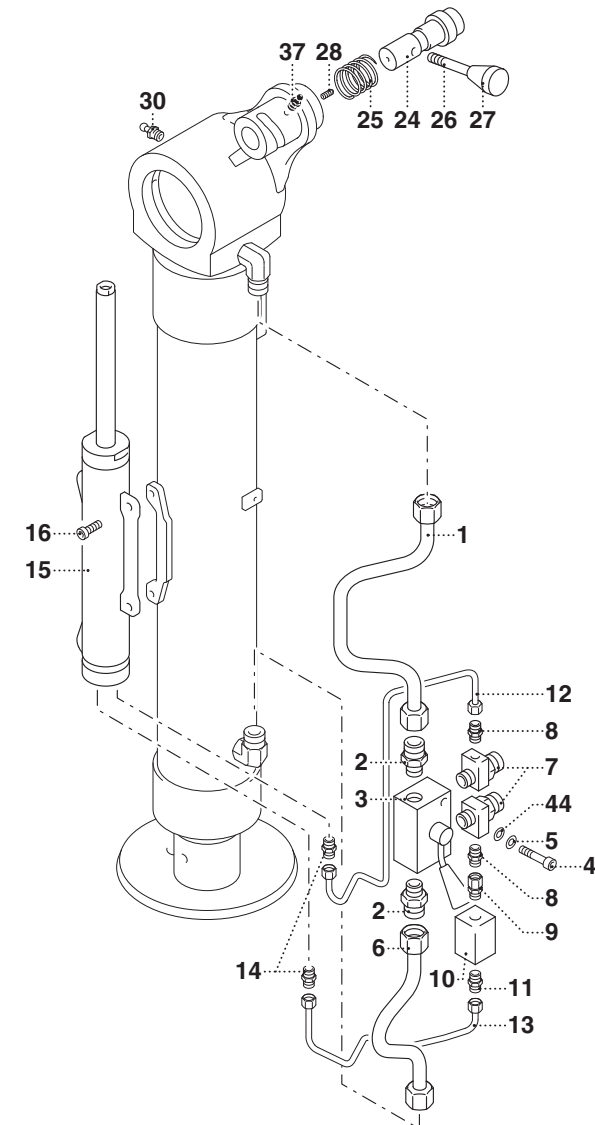
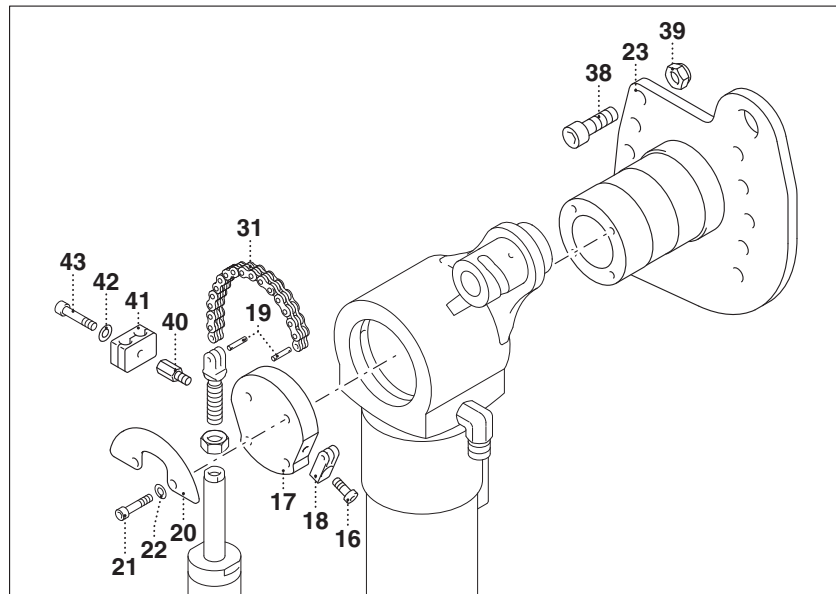
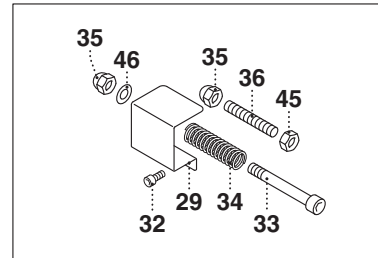

PM 21 - PM 23 P

matr. G107.0005

TAV. GK.02.02

POS.	N° CODICE	Q.	DESCRIZIONE	DESIGNATION	BENENNUNG	DESCRIPTION	DENOMINACIONES
1	493977	1	TUBO RIGIDO	TUYAU RIGIDE	ROHR	PIPE	TUBO RIGIDO
2	409831	2	RACCORDO	RACCORD	ANSCHLUSS	FITTING	RACOR
3	421004	1	VALVOLA	SOUPAPE	VENTIL	VALVE	VALVULA
4	497115	1	VITE	VIS	SCHRAUBE	SCREW	TORNILLO
5	417228	1	RONDELLA	RONDELLE	SCHEIBE	WASHER	ARANDELA
6	460144	1	TUBO RIGIDO	TUYAU RIGIDE	ROHR	PIPE	TUBO RIGIDO
7	409147	2	RACCORDO	RACCORD	ANSCHLUSS	FITTING	RACOR
8	409665	2	RACCORDO	RACCORD	ANSCHLUSS	FITTING	RACOR
9	409761	1	RACCORDO	RACCORD	ANSCHLUSS	FITTING	RACOR
10	495632	1	VALVOLA	SOUPAPE	VENTIL	VALVE	VALVULA
11	409664	1	RACCORDO	RACCORD	ANSCHLUSS	FITTING	RACOR
12	460040	1	TUBO RIGIDO	TUYAU RIGIDE	ROHR	PIPE	TUBO RIGIDO
13	460039	1	TUBO RIGIDO	TUYAU RIGIDE	ROHR	PIPE	TUBO RIGIDO
14	410109	2	RACCORDO	RACCORD	ANSCHLUSS	FITTING	RACOR
15	340354	1	MARTINETTO	VERIN	ZYLINDER	CYLINDER	CILINDRO
16	497238	3	VITE	VIS	SCHRAUBE	SCREW	TORNILLO
17	467430	1	SUPPORTO	SUPPORT	TRÄGER	SUPPORT	SOPORTE
18	123496	1	ATTACCO	ATTACHE	VERBINDUNG	COUPLING	ENCHUFE
19	380279	2	PERNO	AXE	BOLZEN	PIN	PERNO
20	176393	1	COPERCHIO	COUVERCLE	DECKEL	COVER	TAPA
21	497135	4	VITE	VIS	SCHRAUBE	SCREW	TORNILLO
22	417025	4	RONDELLA	RONDELLE	SCHEIBE	WASHER	ARANDELA
23	467505	1	SUPPORTO	SUPPORT	TRÄGER	SUPPORT	SOPORTE
24	380466	1	PERNO	AXE	BOLZEN	PIN	PERNO
25	349140	1	MOLLA	RESSORT	FEDER	SPRING	MUELLE
26	322039	1	LEVA	LEVIER	HEBEL	LEVER	PALANCA



KIT MARTINETTO STABILIZZATORI ROTANTI - 340428

* Kit vérin stabilisateurs tournants
* Drehstützzylindersatz
* Rotating outriggers cylinders kit
* Kit cilindro estabilizadores rotatorios

TAV. GK.02.02

matr. G107.0005

21
23 P

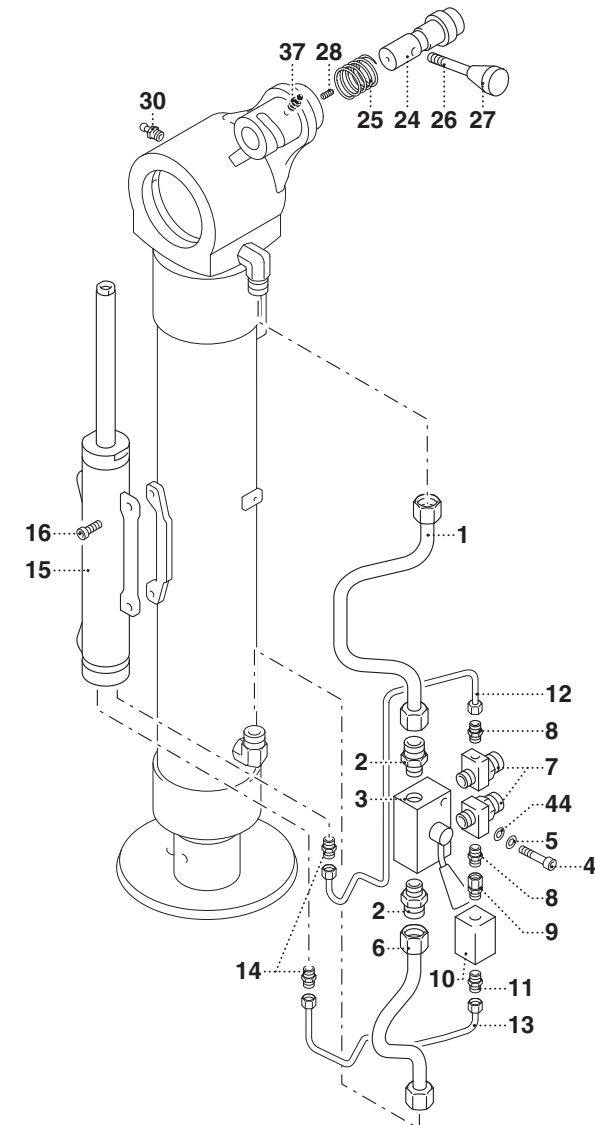
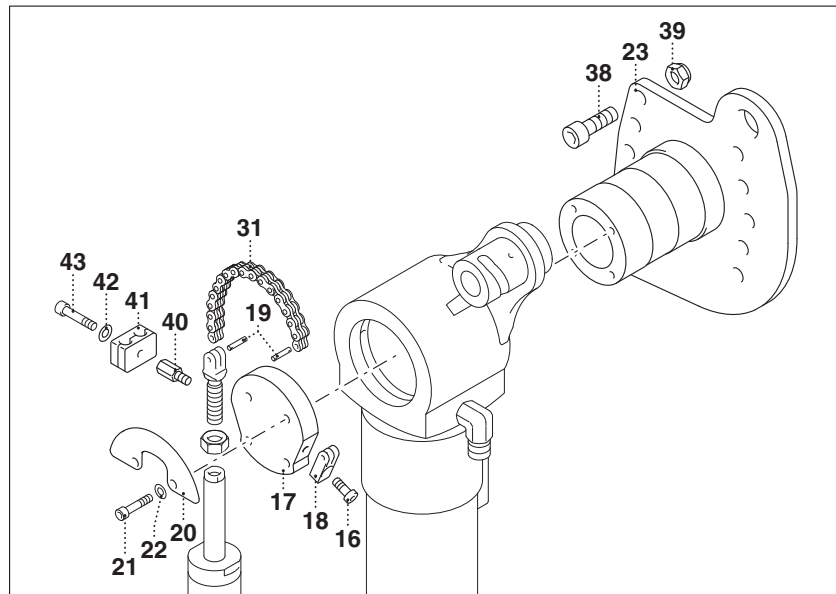
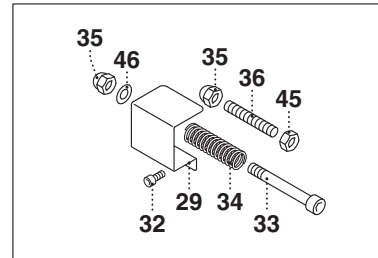

PM 21 - PM 23 P

matr. G107.0005

TAV. GK.02.02

POS.	N° CODICE	Q.	DESCRIZIONE	DESIGNATION	BENENNUNG	DESCRIPTION	DENOMINACIONES
27	385007	1	POMELLO	POMMEAU	KNOPF	KNOB	POMO
28	497260	1	VITE	VIS	SCHRAUBE	SCREW	TORNILLO
29	176416	1	CARTER	CARTER	GEHÄUSE	CASING	CARTER
30	281010	2	INGRASSATORE	GRAISSEUR	SCHMIERER	GREASE FITTING	ENGRASADOR
31	151071	1	CATENA	CHAINE	KETTE	CHAIN	CADENA
32	497588	2	VITE	VIS	SCHRAUBE	SCREW	TORNILLO
33	497156	1	VITE	VIS	SCHRAUBE	SCREW	TORNILLO
34	349143	1	MOLLA	RESSORT	FEDER	SPRING	MUELLE
35	191215	2	DADO	ECROU	MUTTER	NUT	TUERCA
36	497265	1	VITE	VIS	SCHRAUBE	SCREW	TORNILLO
37	281004	1	INGRASSATORE	GRAISSEUR	SCHMIERER	GREASE FITTING	ENGRASADOR
38	497178	10	VITE	VIS	SCHRAUBE	SCREW	TORNILLO
39	191160	10	RONDELLA	RONDELLE	SCHEIBE	WASHER	ARANDELA
40	136749	1	DISTANZIALE	ENTRETOISE	DISTANZSTÜCK	SPACER	DISTANCIADOR
41	353076	1	MORSETTO	ETAU	KLEMME	CLAMP	PRENSOR
42	417004	1	RONDELLA	RONDELLE	SCHEIBE	WASHER	ARANDELA
43	497123	1	VITE	VIS	SCHRAUBE	SCREW	TORNILLO
44	417050	1	RONDELLA	RONDELLE	SCHEIBE	WASHER	ARANDELA
45	191064	1	DADO	ECROU	MUTTER	NUT	TUERCA
46	417005	1	RONDELLA	RONDELLE	SCHEIBE	WASHER	ARANDELA



COMANDO MARTINETTO STABILIZZATORE (BRACCI STANDARD MANUALI FISSI-ROTANTI)

- * *Commande vérin stabilisateur (bras standard manuels fixes-tournants)*
- * *Stützzylindersteuerung (Fest-Dreh-Manual Standardarme)*
- * *Outrigger cylinder control (fixed-rotating manual standard arms)*
- * *Mando gatos de apoyo (brazos estándar manuales fijos-rotatorios)*

TAV. GK.03.01 1/2

matr. G107.0005

21
23 P

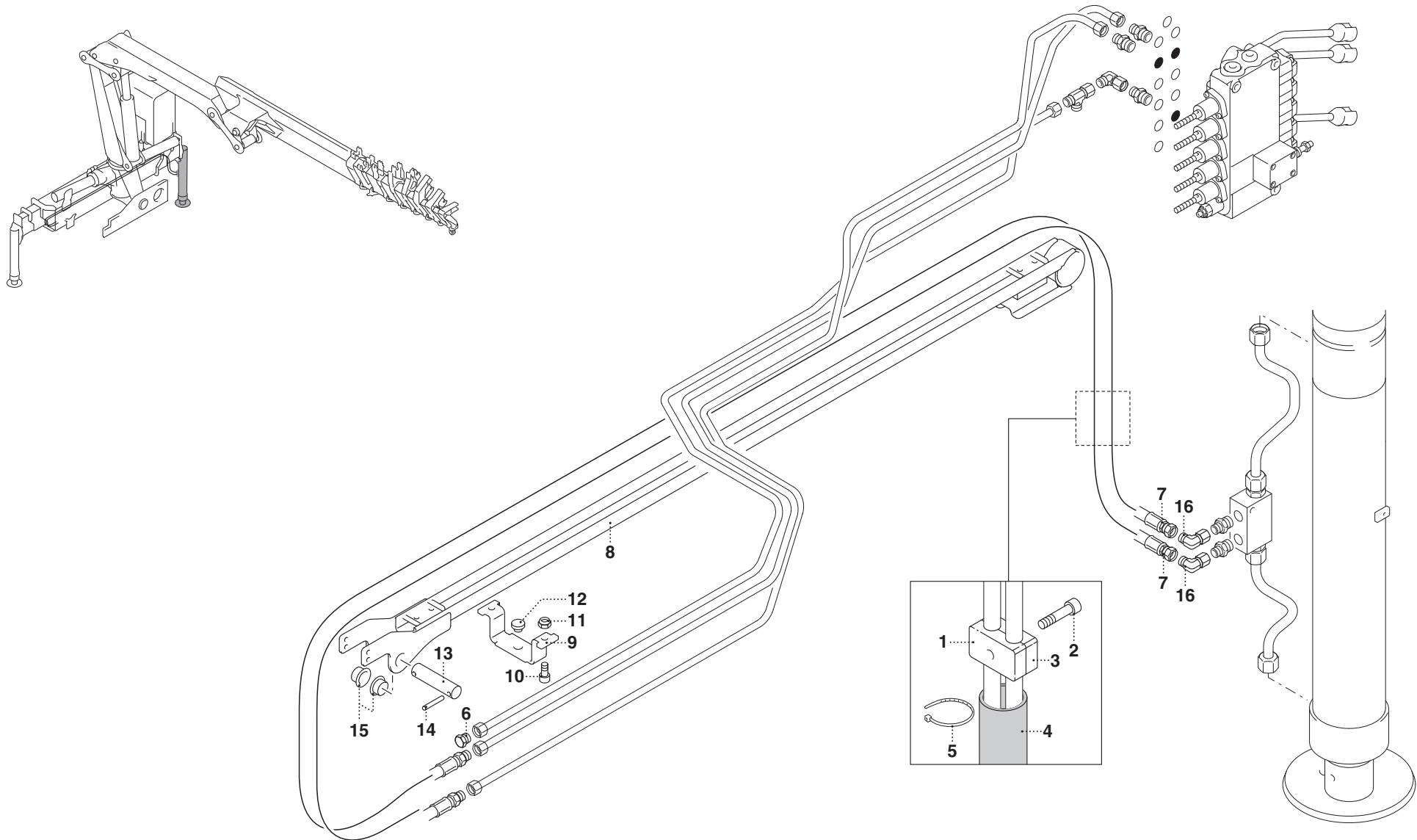

PM 21 - PM 23 P**matr. G107.0005****TAV. GK.03.01 1/2**

POS.	N° CODICE	Q.	DESCRIZIONE	DESIGNATION	BENENNUNG	DESCRIPTION	DENOMINACIONES
1	353060	1	MORSETTO	ETAU	KLEMME	CLAMP	PRENSOR
2	497121	1	VITE	VIS	SCHRAUBE	SCREW	TORNILLO
3	353076	1	MORSETTO	ETAU	KLEMME	CLAMP	PRENSOR
4	276059	1	GUAINA	GAINE	MANTEL	SHEATH	VAINA
5	207064	2	FASCETTA	COLLIER	HALTEBAND	CLAMP	ABRAZADERA
6	471189	1	TAPPO	BOUCHON	VERSCHLUSSDECKEL	PLUG	TAPON
7	482582	2	TUBO FLESSIBILE	TUYAU FLEXIBLE	SCHLAUCH	FLEXIBLE HOSE	TUBO FLEXIBLE
8	467033	1	SUPPORTO	SUPPORT	TRÄGER	SUPPORT	SOPORTE
9	467489	1	SUPPORTO	SUPPORT	TRÄGER	SUPPORT	SOPORTE
10	497383	2	VITE	VIS	SCHRAUBE	SCREW	TORNILLO
11	191168	2	DADO	ECROU	MUTTER	NUT	TUERCA
12	373475	1	PATTINO	PATIN	GLEITBLOCK	SLIDING BLOCK	PATIN
13	380423	1	PERNO	AXE	BOLZEN	PIN	PERNO
14	455212	2	SPINA	GOUPILLE	STIFT	PIN	PASADOR
15	136901	2	BOCCOLA	DOUILLE	BUCHSE	BUSHING	CASQUILLO
16	409633	2	RACCORDO	RACCORD	ANSCHLUSS	FITTING	RACOR



COMANDO MARTINETTO STABILIZZATORE (BRACCI STANDARD MANUALI FISSI-ROTANTI)

- * *Commande vérin stabilisateur (bras standard manuels fixes-tournants)*
- * *Stützzylindersteuerung (Fest-Dreh-Manual Standardarme)*
- * *Outrigger cylinder control (fixed-rotating manual standard arms)*
- * *Mando gatos de apoyo (brazos estándar manuales fijos-rotatorios)*

TAV. GK.03.01 2/2

matr. G107.0005

21
23 P

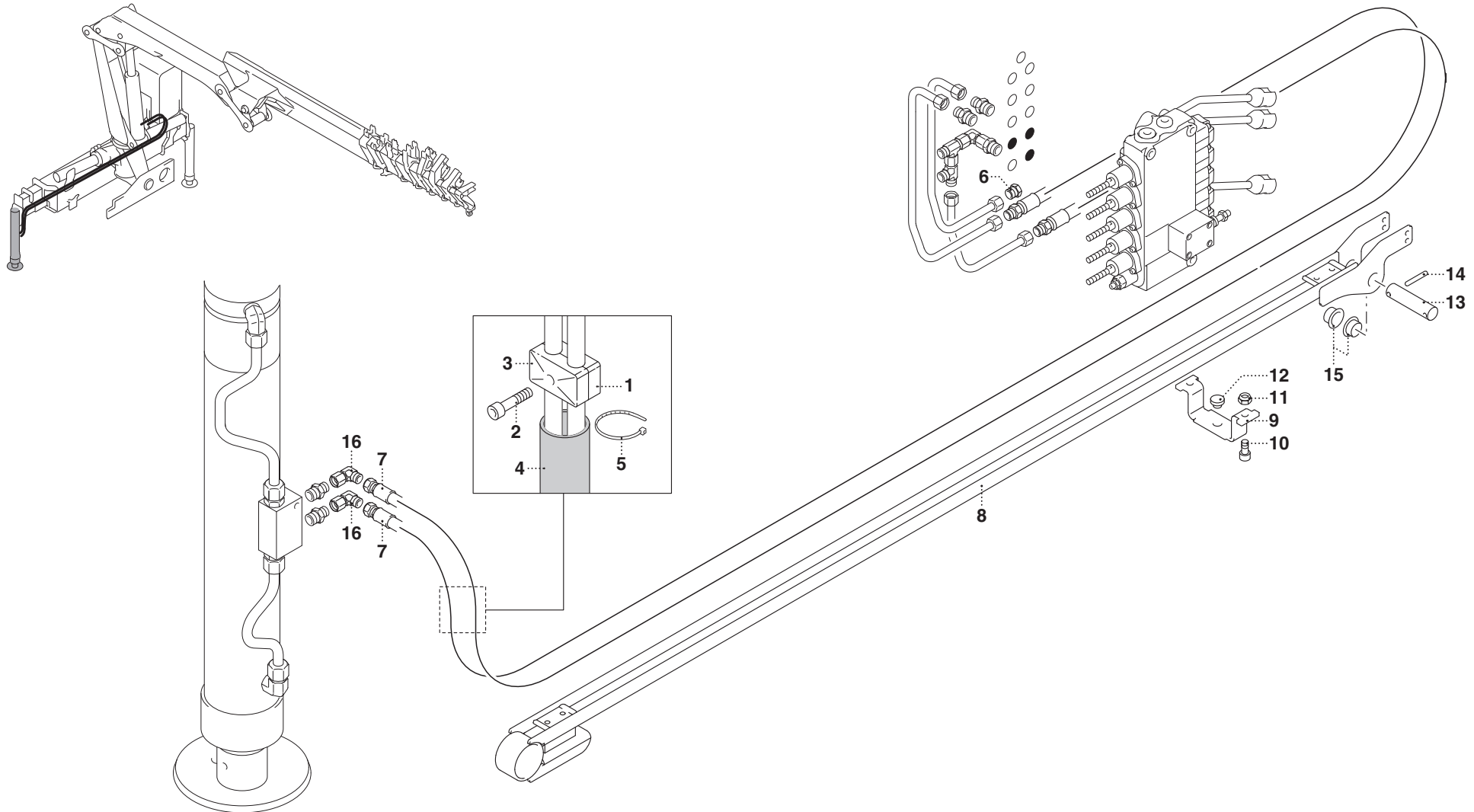

PM 21 - PM 23 P**matr. G107.0005****TAV. GK.03.01 2/2**

POS.	N° CODICE	Q.	DESCRIZIONE	DESIGNATION	BENENNUNG	DESCRIPTION	DENOMINACIONES
1	353060	1	MORSETTO	ETAU	KLEMME	CLAMP	PRENSOR
2	497121	1	VITE	VIS	SCHRAUBE	SCREW	TORNILLO
3	353076	1	MORSETTO	ETAU	KLEMME	CLAMP	PRENSOR
4	276059	1	GUAINA	GAINE	MANTEL	SHEATH	VAINA
5	207064	2	FASCETTA	COLLIER	HALTEBAND	CLAMP	ABRAZADERA
6	471189	1	TAPPO	BOUCHON	VERSCHLUSSDECKEL	PLUG	TAPON
7	482582	2	TUBO FLESSIBILE	TUYAU FLEXIBLE	SCHLAUCH	FLEXIBLE HOSE	TUBO FLEXIBLE
8	467033	1	SUPPORTO	SUPPORT	TRÄGER	SUPPORT	SOPORTE
9	467489	1	SUPPORTO	SUPPORT	TRÄGER	SUPPORT	SOPORTE
10	497383	2	VITE	VIS	SCHRAUBE	SCREW	TORNILLO
11	191168	2	DADO	ECROU	MUTTER	NUT	TUERCA
12	373475	1	PATTINO	PATIN	GLEITBLOCK	SLIDING BLOCK	PATIN
13	380423	1	PERNO	AXE	BOLZEN	PIN	PERNO
14	455212	2	SPINA	GOUPILLE	STIFT	PIN	PASADOR
15	136901	2	BOCCOLA	DOUILLE	BUCHSE	BUSHING	CASQUILLO
16	409633	2	RACCORDO	RACCORD	ANSCHLUSS	FITTING	RACOR

PM 21 - PM 23 P

matr. G107.0005

TAV. GK.03.02 1/2

POS.	N° CODICE	Q.	DESCRIZIONE	DESIGNATION	BENENNUNG	DESCRIPTION	DENOMINACIONES
1	417024	1	RONDELLA	RONDELLE	SCHEIBE	WASHER	ARANDELA
2	497123	1	VITE	VIS	SCHRAUBE	SCREW	TORNILLO
3	467611	1	SUPPORTO	SUPPORT	TRÄGER	SUPPORT	SOPORTE
4	191125	1	DADO	ECROU	MUTTER	NUT	TUERCA
5	497121	1	VITE	VIS	SCHRAUBE	SCREW	TORNILLO
6	495645	2	VALVOLA	SOUPAPE	VENTIL	VALVE	VALVULA
7	482582	2	TUBO FLESSIBILE	TUYAU FLEXIBLE	SCHLAUCH	FLEXIBLE HOSE	TUBO FLEXIBLE
8	410016	1	RACCORDO	RACCORD	ANSCHLUSS	FITTING	RACOR
9	460198	1	TUBO RIGIDO	TUYAU RIGIDE	ROHR	PIPE	TUBO RIGIDO
10	353076	2	MORSETTO	ETAU	KLEMME	CLAMP	PRENSOR
11	409907	1	RACCORDO	RACCORD	ANSCHLUSS	FITTING	RACOR
12	410071	3	RACCORDO	RACCORD	ANSCHLUSS	FITTING	RACOR
13	460199	1	TUBO RIGIDO	TUYAU RIGIDE	ROHR	PIPE	TUBO RIGIDO
14	497967	4	VITE	VIS	SCHRAUBE	SCREW	TORNILLO
15	467377	1	SUPPORTO	SUPPORT	TRÄGER	SUPPORT	SOPORTE
16	151074	1	CATENA PORTACAVI	CHAINE PORTE-CABLE	SCHLEPPKETTE	HOLDER-CABLES CHAIN	CADENA PORTA-CABLES
17	276059	1	GUAINA	GAINÉ	MANTEL	SHEATH	VAINA
18	207064	2	FASCETTA	COLLIER	HALTEBAND	CLAMP	ABRAZADERA
19	497486	2	VITE	VIS	SCHRAUBE	SCREW	TORNILLO
20	497485	2	VITE	VIS	SCHRAUBE	SCREW	TORNILLO
21	417002	4	RONDELLA	RONDELLE	SCHEIBE	WASHER	ARANDELA
22	191046	8	DADO	ECROU	MUTTER	NUT	TUERCA
23	467486	1	SUPPORTO	SUPPORT	TRÄGER	SUPPORT	SOPORTE
24	497499	2	VITE	VIS	SCHRAUBE	SCREW	TORNILLO
25	373932	2	PATTINO	PATIN	GLEITBLOCK	SLIDING BLOCK	PATIN
26	455023	4	SPINA	GOUPILLE	STIFT	PIN	PASADOR



COMANDO MARTINETTO STABILIZZATORE (BRACCI STANDARD IDRAULICI FISSI-ROTANTI)

- * *Commande vérin stabilisateur (bras standard hydrauliques fixes-tournants)*
- * *Stützzylindersteuerung (Fest-Dreh-Hydraulik Standardarme)*
- * *Outrigger cylinder control (fixed-rotating hydraulic standard arms)*
- * *Mando gatos de apoyo (brazos estándar hidráulicos fijos-rotatorios)*

TAV. GK.03.02 1/2

matr. G107.0005

21
23 P

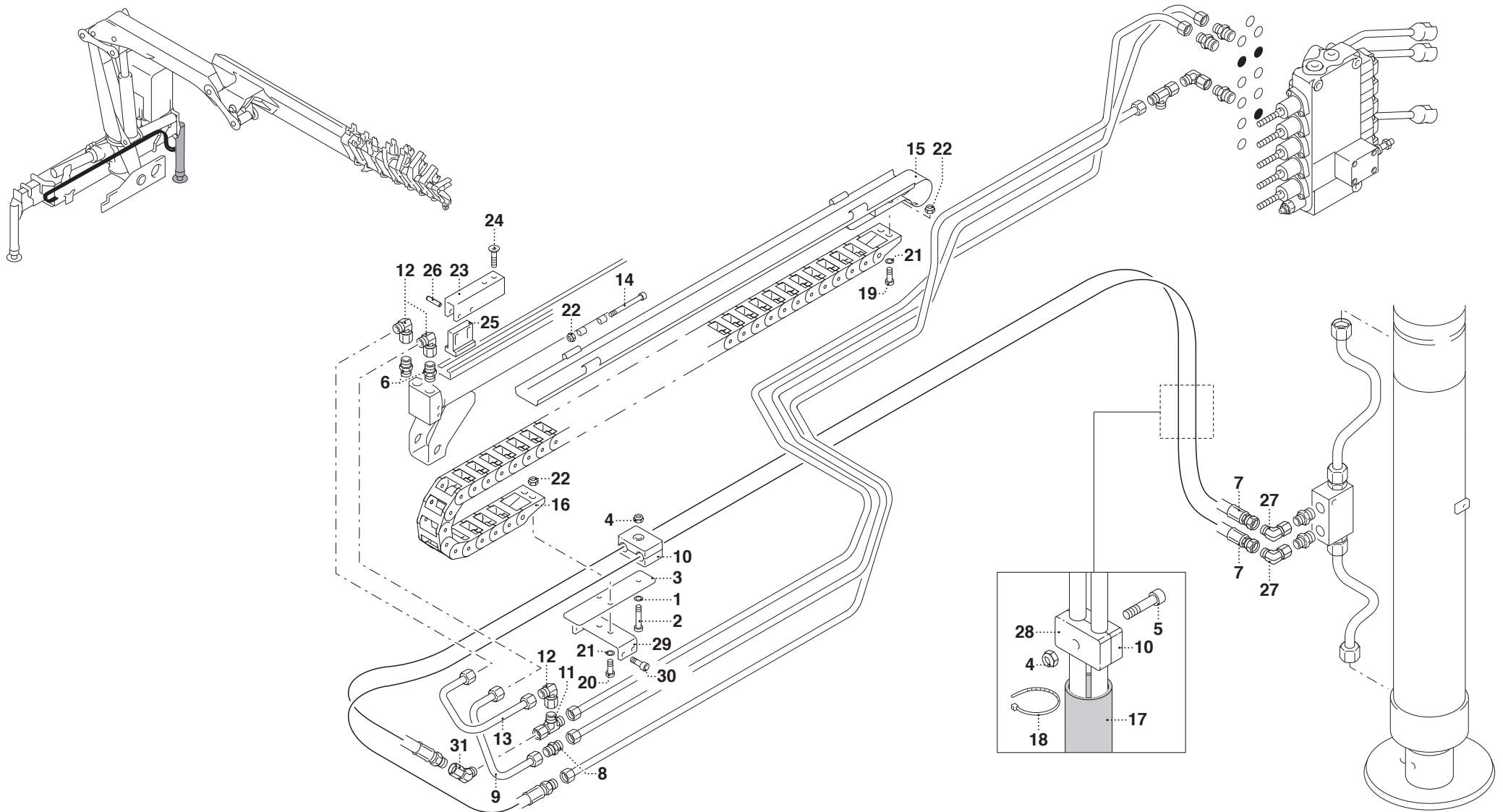

PM 21 - PM 23 P

matr. G107.0005

TAV. GK.03.02 2/2

POS.	N° CODICE	Q.	DESCRIZIONE	DESIGNATION	BENENNUNG	DESCRIPTION	DENOMINACIONES
1	417024	1	RONDELLA	RONDELLE	SCHEIBE	WASHER	ARANDELA
2	497123	1	VITE	VIS	SCHRAUBE	SCREW	TORNILLO
3	467611	1	SUPPORTO	SUPPORT	TRÄGER	SUPPORT	SOPORTE
4	191125	1	DADO	ECROU	MUTTER	NUT	TUERCA
5	497121	1	VITE	VIS	SCHRAUBE	SCREW	TORNILLO
6	495645	2	VALVOLA	SOUPAPE	VENTIL	VALVE	VALVULA
7	482582	2	TUBO FLESSIBILE	TUYAU FLEXIBLE	SCHLAUCH	FLEXIBLE HOSE	TUBO FLEXIBLE
8	410071	3	RACCORDO	RACCORD	ANSCHLUSS	FITTING	RACOR
9	410016	1	RACCORDO	RACCORD	ANSCHLUSS	FITTING	RACOR
10	460198	1	TUBO RIGIDO	TUYAU RIGIDE	ROHR	PIPE	TUBO RIGIDO
11	409907	1	RACCORDO	RACCORD	ANSCHLUSS	FITTING	RACOR
12	460199	1	TUBO RIGIDO	TUYAU RIGIDE	ROHR	PIPE	TUBO RIGIDO
13	353076	2	MORSETTO	ETAU	KLEMME	CLAMP	PRENSOR
14	497967	4	VITE	VIS	SCHRAUBE	SCREW	TORNILLO
15	467377	1	SUPPORTO	SUPPORT	TRÄGER	SUPPORT	SOPORTE
16	151074	1	CATENA PORTACAVI	CHAINE PORTE-CABLE	SCHLEPPKETTE	HOLDER-CABLES CHAIN	CADENA PORTA-CABLES
17	276059	1	GUAINA	GAINÉ	MANTEL	SHEATH	VAINA
18	207064	2	FASCETTA	COLLIER	HALTEBAND	CLAMP	ABRAZADERA
19	497486	2	VITE	VIS	SCHRAUBE	SCREW	TORNILLO
20	497485	2	VITE	VIS	SCHRAUBE	SCREW	TORNILLO
21	417002	4	RONDELLA	RONDELLE	SCHEIBE	WASHER	ARANDELA
22	191046	8	DADO	ECROU	MUTTER	NUT	TUERCA
23	497499	2	VITE	VIS	SCHRAUBE	SCREW	TORNILLO
24	455023	4	SPINA	GOUPILLE	STIFT	PIN	PASADOR
25	373932	2	PATTINO	PATIN	GLEITBLOCK	SLIDING BLOCK	PATIN
26	467486	1	SUPPORTO	SUPPORT	TRÄGER	SUPPORT	SOPORTE



COMANDO MARTINETTO STABILIZZATORE (BRACCI SUPER EXTRALARGHI IDRAULICI FISSI-ROTANTI)

- * *Commande vérin stabilisateur (bras super extra larges hydrauliques fixes-tournants)*
- * *Stützzylindersteuerung (Fest-Dreh-Hydraulik super Extrabreitearme)*
- * *Outrigger cylinder control (fixed-rotating hydraulic super extra-large arms)*
- * *Mando gatos de apoyo (brazos super extra anchos hidráulicos fijos-rotatorios)*

TAV. GK.03.03 1/2

matr. G107.0005

21
23 P

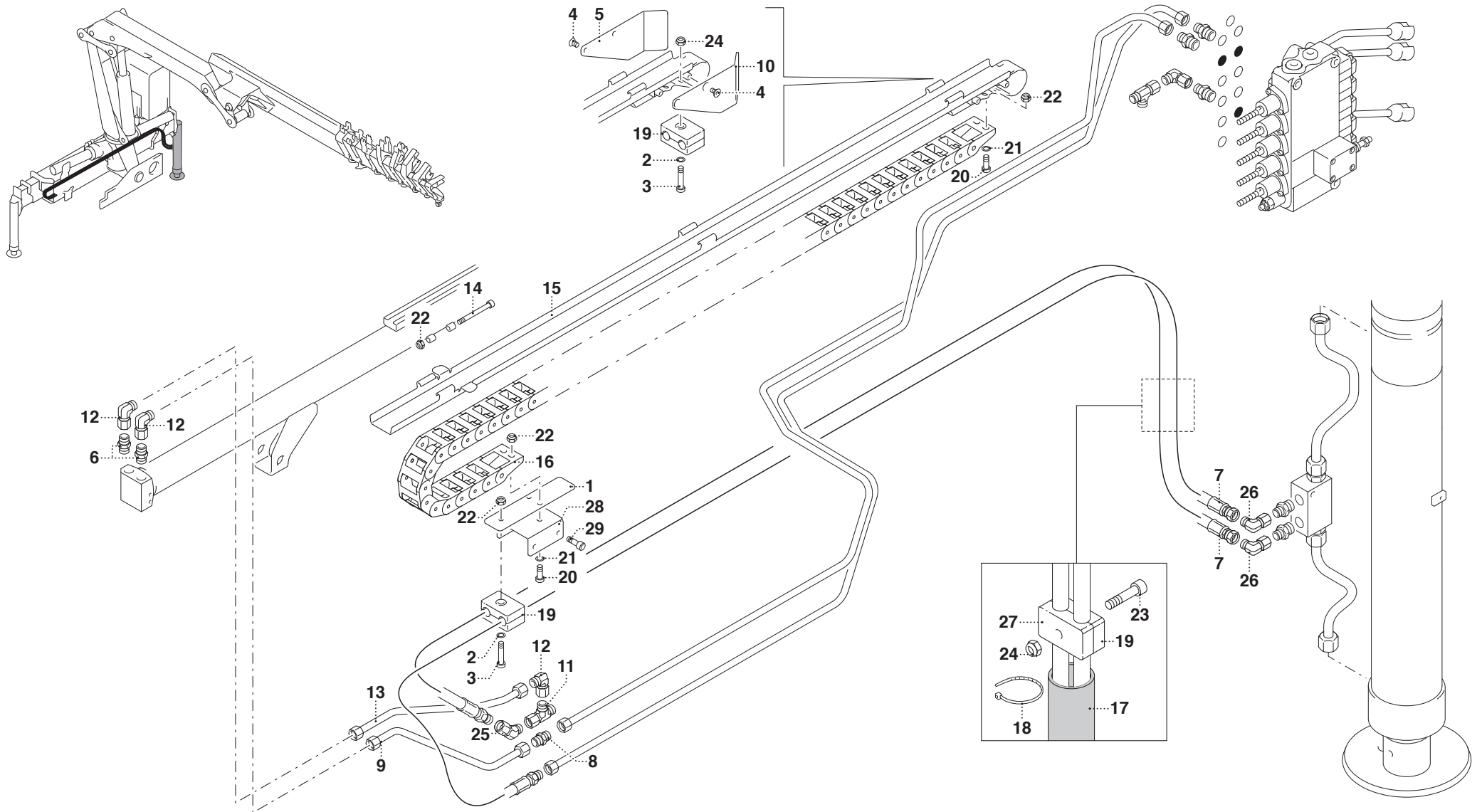

PM 21 - PM 23 P

matr. G107.0005

TAV. GK.03.03 1/2

POS.	N° CODICE	Q.	DESCRIZIONE	DESIGNATION	BENENNUNG	DESCRIPTION	DENOMINACIONES
1	467611	1	SUPPORTO	SUPPORT	TRÄGER	SUPPORT	SOPORTE
2	417024	2	RONDELLA	RONDELLE	SCHEIBE	WASHER	ARANDELA
3	497123	2	VITE	VIS	SCHRAUBE	SCREW	TORNILLO
4	497983	4	VITE	VIS	SCHRAUBE	SCREW	TORNILLO
5	176438	1	CARTER	CARTER	GEHÄUSE	CASING	CARTER
6	495645	2	VALVOLA	SOUPAPE	VENTIL	VALVE	VALVULA
7	482583	2	TUBO FLESSIBILE	TUYAU FLEXIBLE	SCHLAUCH	FLEXIBLE HOSE	TUBO FLEXIBLE
8	410016	1	RACCORDO	RACCORD	ANSCHLUSS	FITTING	RACOR
9	460197	1	TUBO RIGIDO	TUYAU RIGIDE	ROHR	PIPE	TUBO RIGIDO
10	176437	1	CARTER	CARTER	GEHÄUSE	CASING	CARTER
11	409907	1	RACCORDO	RACCORD	ANSCHLUSS	FITTING	RACOR
12	410071	3	RACCORDO	RACCORD	ANSCHLUSS	FITTING	RACOR
13	460196	1	TUBO RIGIDO	TUYAU RIGIDE	ROHR	PIPE	TUBO RIGIDO
14	497967	6	VITE	VIS	SCHRAUBE	SCREW	TORNILLO
15	467470	1	SUPPORTO	SUPPORT	TRÄGER	SUPPORT	SOPORTE
16	151080	1	CATENA PORTACAVI	CHAINE PORTE-CABLE	SCHLEPPKETTE	HOLDER-CABLES CHAIN	CADENA PORTA-CABLES
17	276059	1	GUAINA	GAINÉ	MANTEL	SHEATH	VAINA
18	207064	2	FASCETTA	COLLIER	HALTEBAND	CLAMP	ABRAZADERA
19	353076	3	MORSETTO	ETAU	KLEMME	CLAMP	PRENSOR
20	497486	4	VITE	VIS	SCHRAUBE	SCREW	TORNILLO
21	417002	4	RONDELLA	RONDELLE	SCHEIBE	WASHER	ARANDELA
22	191046	10	DADO	ECROU	MUTTER	NUT	TUERCA
23	497121	1	VITE	VIS	SCHRAUBE	SCREW	TORNILLO
24	191125	2	DADO	ECROU	MUTTER	NUT	TUERCA
25	410438	1	RACCORDO	RACCORD	ANSCHLUSS	FITTING	RACOR
26	410117	2	RACCORDO	RACCORD	ANSCHLUSS	FITTING	RACOR



COMANDO MARTINETTO STABILIZZATORE (BRACCI SUPER EXTRALARGHI IDRAULICI FISSI-ROTANTI)

* *Commande vérin stabilisateur (bras super extra larges hydrauliques fixes-tournants)*

* *Stützzylindersteuerung (Fest-Dreh-Hydraulik super Extrabreitearme)*

* *Outrigger cylinder control (fixed-rotating hydraulic super extra-large arms)*

* *Mando gatos de apoyo (brazos super extra anchos hidráulicos fijos-rotatorios)*

TAV. GK.03.03 2/2

matr. G107.0005

21
23 P

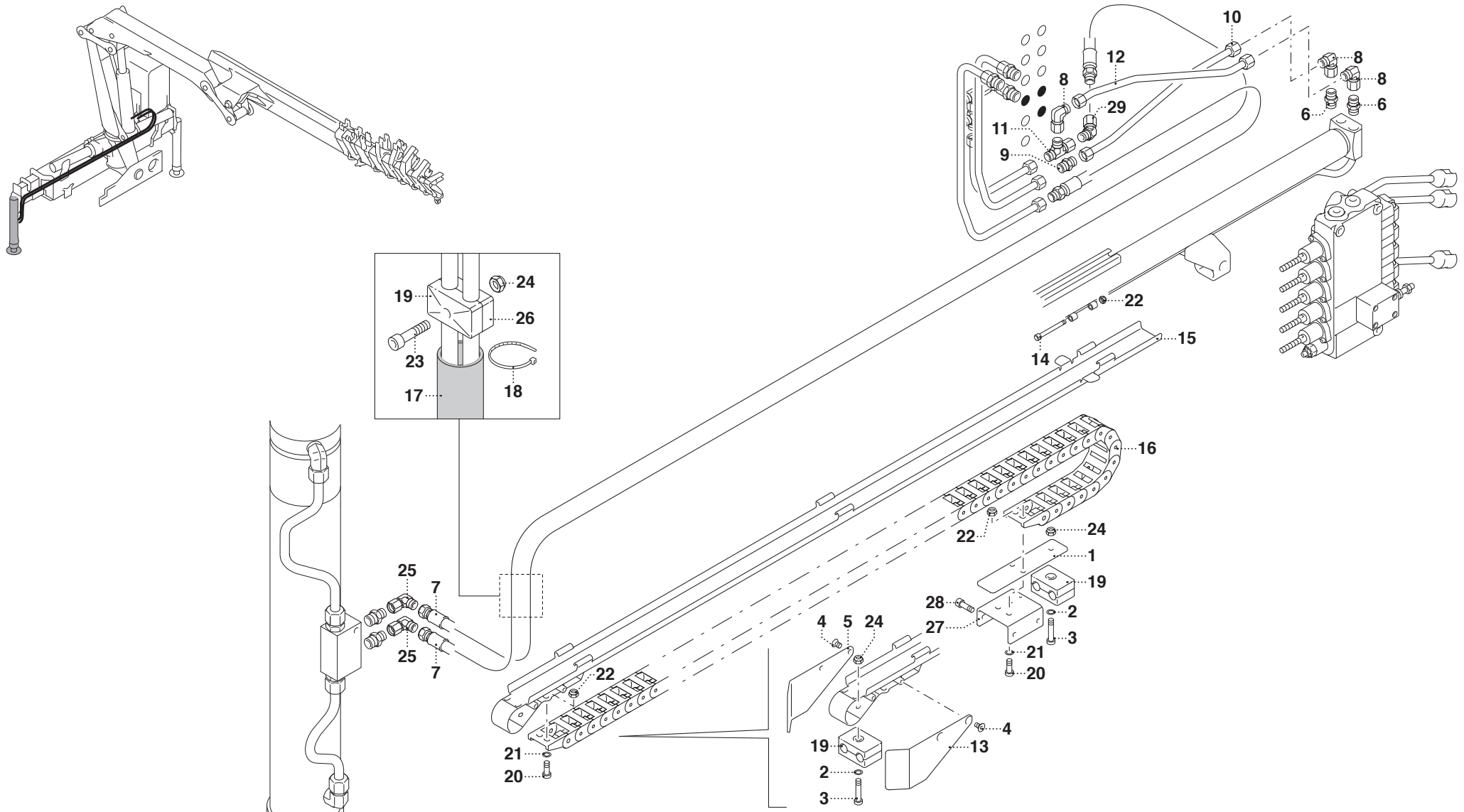

PM 21 - PM 23 P

matr. G107.0005

TAV. GK.03.03 2/2

POS.	N° CODICE	Q.	DESCRIZIONE	DESIGNATION	BENENNUNG	DESCRIPTION	DENOMINACIONES
1	467611	1	SUPPORTO	SUPPORT	TRÄGER	SUPPORT	SOPORTE
2	417024	2	RONDELLA	RONDELLE	SCHEIBE	WASHER	ARANDELA
3	497123	2	VITE	VIS	SCHRAUBE	SCREW	TORNILLO
4	497983	4	VITE	VIS	SCHRAUBE	SCREW	TORNILLO
5	176438	1	CARTER	CARTER	GEHÄUSE	CASING	CARTER
6	495645	2	VALVOLA	SOUPAPE	VENTIL	VALVE	VALVULA
7	482583	2	TUBO FLESSIBILE	TUYAU FLEXIBLE	SCHLAUCH	FLEXIBLE HOSE	TUBO FLEXIBLE
8	410071	3	RACCORDO	RACCORD	ANSCHLUSS	FITTING	RACOR
9	410016	1	RACCORDO	RACCORD	ANSCHLUSS	FITTING	RACOR
10	460197	1	TUBO RIGIDO	TUYAU RIGIDE	ROHR	PIPE	TUBO RIGIDO
11	409616	1	RACCORDO	RACCORD	ANSCHLUSS	FITTING	RACOR
12	460196	1	TUBO RIGIDO	TUYAU RIGIDE	ROHR	PIPE	TUBO RIGIDO
13	176437	1	CARTER	CARTER	GEHÄUSE	CASING	CARTER
14	497967	6	VITE	VIS	SCHRAUBE	SCREW	TORNILLO
15	467470	1	SUPPORTO	SUPPORT	TRÄGER	SUPPORT	SOPORTE
16	151080	1	CATENA PORTACAVI	CHAINE PORTE-CABLE	SCHLEPPKETTE	HOLDER-CABLES CHAIN	CADENA PORTA-CABLES
17	276059	1	GUAINA	GAINÉ	MANTEL	SHEATH	VAINA
18	207064	2	FASCETTA	COLLIER	HALTEBAND	CLAMP	ABRAZADERA
19	353076	3	MORSETTO	ETAU	KLEMME	CLAMP	PRENSOR
20	497486	4	VITE	VIS	SCHRAUBE	SCREW	TORNILLO
21	417002	4	RONDELLA	RONDELLE	SCHEIBE	WASHER	ARANDELA
22	191046	10	DADO	ECROU	MUTTER	NUT	TUERCA
23	497121	1	VITE	VIS	SCHRAUBE	SCREW	TORNILLO
24	191125	2	DADO	ECROU	MUTTER	NUT	TUERCA
25	410117	2	RACCORDO	RACCORD	ANSCHLUSS	FITTING	RACOR
26	353060	1	MORSETTO	ETAU	KLEMME	CLAMP	PRENSOR



COMANDO ROTAZIONE - HYDROCONTROL (21)

- * *Commande rotation - HYDROCONTROL*
- * *Schwenksteuerung - HYDROCONTROL*
- * *Rotation control - HYDROCONTROL*
- * *Mando rotación - HYDROCONTROL*

TAV. GK.04.01

matr. G107.0005

21
23 P

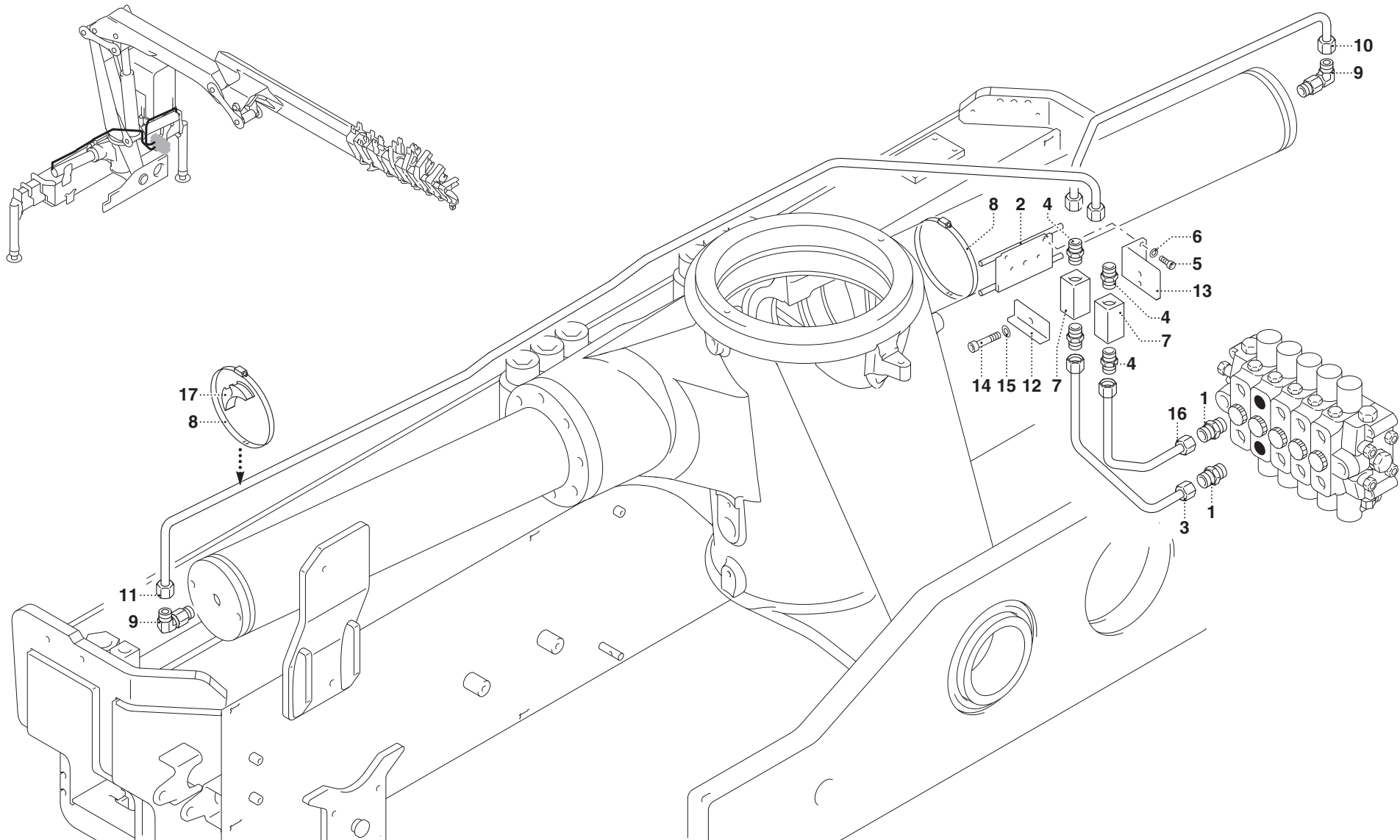

PM 21**matr. G107.0005****TAV. GK.04.01**

POS.	N° CODICE	Q.	DESCRIZIONE	DESIGNATION	BENENNUNG	DESCRIPTION	DENOMINACIONES
1	409632	2	RACCORDO	RACCORD	ANSCHLUSS	FITTING	RACOR
2	465879	1	SUPPORTO	SUPPORT	TRÄGER	SUPPORT	SOPORTE
3	460125	1	TUBO RIGIDO	TUYAU RIGIDE	ROHR	PIPE	TUBO RIGIDO
4	409610	4	RACCORDO	RACCORD	ANSCHLUSS	FITTING	RACOR
5	497118	2	VITE	VIS	SCHRAUBE	SCREW	TORNILLO
6	417024	2	RONDELLA	RONDELLE	SCHEIBE	WASHER	ARANDELA
7	495627	2	VALVOLA	SOUPAPE	VENTIL	VALVE	VALVULA
8	207096	3	FASCETTA	COLLIER	HALTEBAND	CLAMP	ABRAZADERA
9	409617	2	RACCORDO	RACCORD	ANSCHLUSS	FITTING	RACOR
10	460078	1	TUBO RIGIDO	TUYAU RIGIDE	ROHR	PIPE	TUBO RIGIDO
11	460079	1	TUBO RIGIDO	TUYAU RIGIDE	ROHR	PIPE	TUBO RIGIDO
12	466707	1	SUPPORTO	SUPPORT	TRÄGER	SUPPORT	SOPORTE
13	466708	1	SUPPORTO	SUPPORT	TRÄGER	SUPPORT	SOPORTE
14	497136	1	VITE	VIS	SCHRAUBE	SCREW	TORNILLO
15	417025	1	RONDELLA	RONDELLE	SCHEIBE	WASHER	ARANDELA
16	460124	1	TUBO RIGIDO	TUYAU RIGIDE	ROHR	PIPE	TUBO RIGIDO
17	208220	1	FERMO	ARRET	VERSTELLVORRICHTUNG	LOCK	TOPE



COMANDO ROTAZIONE - DANFOSS

- * *Commande rotation - DANFOSS*
- * *Schwenksteuerung - DANFOSS*
- * *Rotation control - DANFOSS*
- * *Mando rotación - DANFOSS*

TAV. GK.04.02

matr. G107.0005

21
23 P

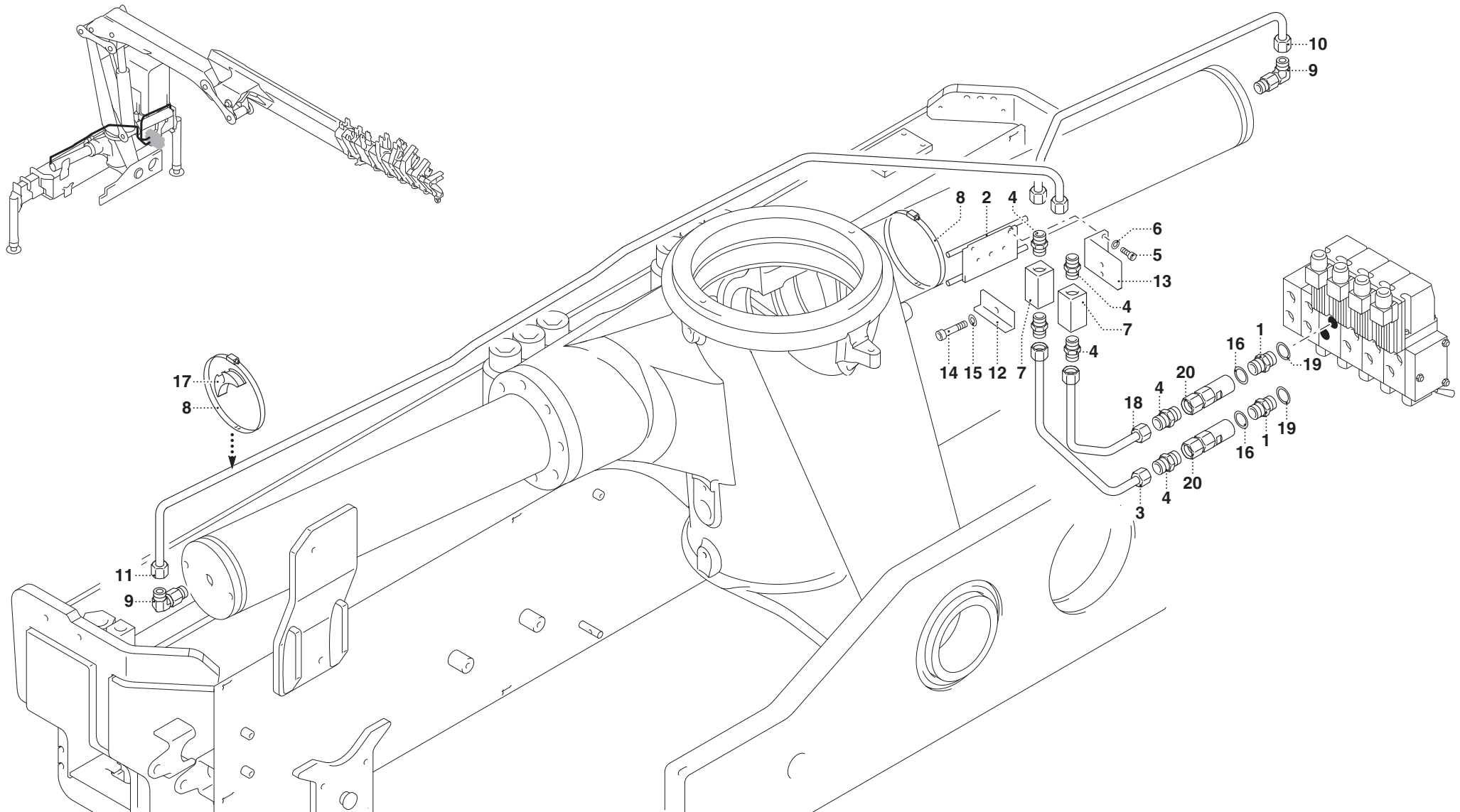

PM 21 - PM 23 P**matr. G107.0005****TAV. GK.04.02**

POS.	N° CODICE	Q.	DESCRIZIONE	DESIGNATION	BENENNUNG	DESCRIPTION	DENOMINACIONES
1	409659	2	RACCORDO	RACCORD	ANSCHLUSS	FITTING	RACOR
2	465879	1	SUPPORTO	SUPPORT	TRÄGER	SUPPORT	SOPORTE
3	460165	1	TUBO RIGIDO	TUYAU RIGIDE	ROHR	PIPE	TUBO RIGIDO
4	409610	6	RACCORDO	RACCORD	ANSCHLUSS	FITTING	RACOR
5	497118	2	VITE	VIS	SCHRAUBE	SCREW	TORNILLO
6	417024	2	RONDELLA	RONDELLE	SCHEIBE	WASHER	ARANDELA
7	495627	2	VALVOLA	SOUPAPE	VENTIL	VALVE	VALVULA
8	207096	3	FASCETTA	COLLIER	HALTEBAND	CLAMP	ABRAZADERA
9	409617	2	RACCORDO	RACCORD	ANSCHLUSS	FITTING	RACOR
10	460078	1	TUBO RIGIDO	TUYAU RIGIDE	ROHR	PIPE	TUBO RIGIDO
11	460079	1	TUBO RIGIDO	TUYAU RIGIDE	ROHR	PIPE	TUBO RIGIDO
12	466707	1	SUPPORTO	SUPPORT	TRÄGER	SUPPORT	SOPORTE
13	466708	1	SUPPORTO	SUPPORT	TRÄGER	SUPPORT	SOPORTE
14	497136	1	VITE	VIS	SCHRAUBE	SCREW	TORNILLO
15	417025	1	RONDELLA	RONDELLE	SCHEIBE	WASHER	ARANDELA
16	417094	2	RONDELLA	RONDELLE	SCHEIBE	WASHER	ARANDELA
17	208220	1	FERMO	ARRET	VERSTELLVORRICHTUNG	LOCK	TOPE
18	460164	1	TUBO RIGIDO	TUYAU RIGIDE	ROHR	PIPE	TUBO RIGIDO
19	417092	2	RONDELLA	RONDELLE	SCHEIBE	WASHER	ARANDELA
20	495562	2	VALVOLA	SOUPAPE	VENTIL	VALVE	VALVULA



COMANDO ROTAZIONE - VALVOLA BLOCCO

- * *Commande rotation - Soupape blocage*
- * *Schwenksteuerung - Sperrventil*
- * *Rotation control - Lock valve*
- * *Mando rotación - Valvula bloqueo*

TAV. GK.04.03

matr. G107.0005

21
23 P

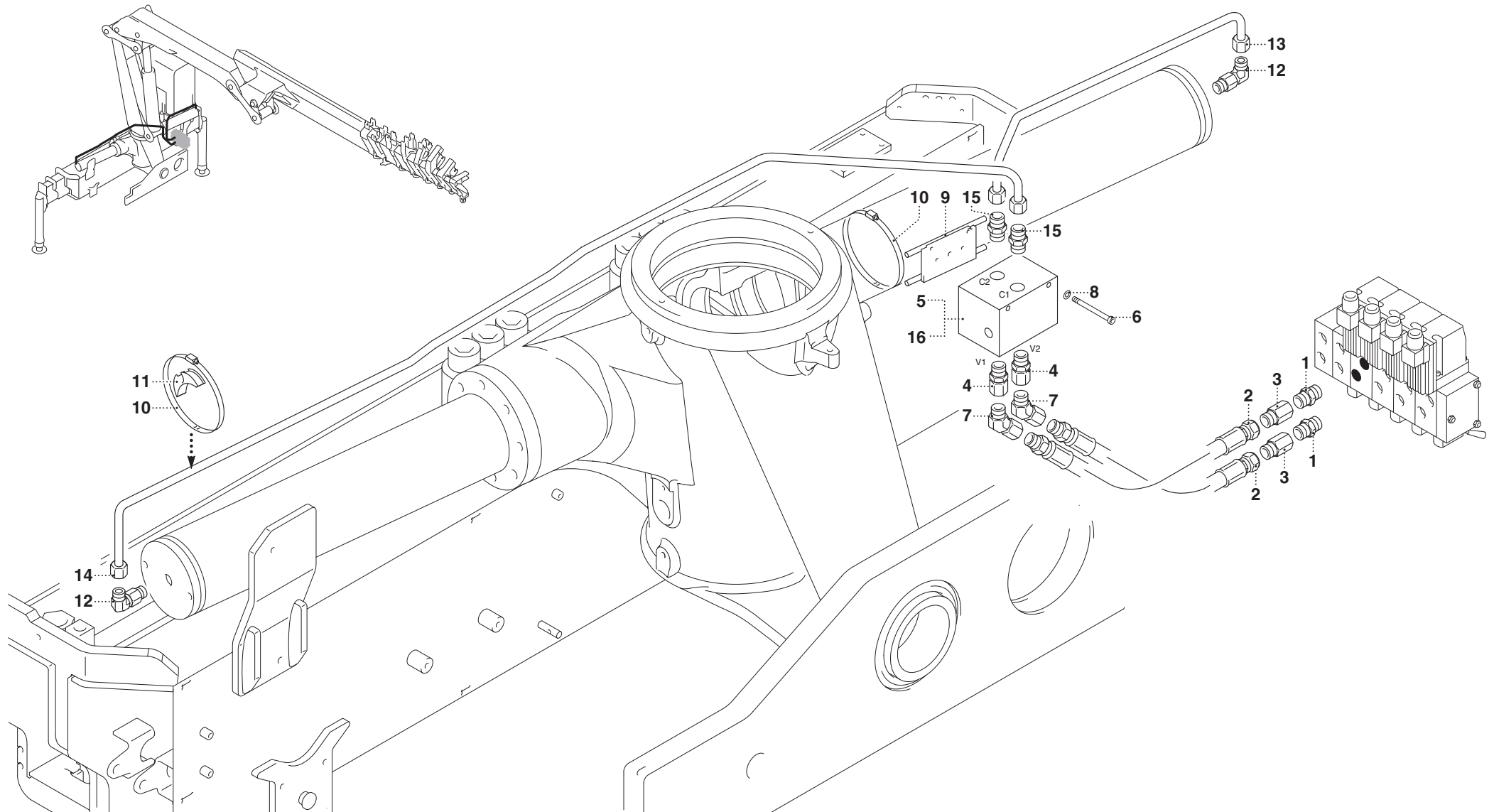

UN01-R-1641-CH

PM 21 - PM 23 P

matr. G107.0005

TAV. GK.04.03

POS.	N° CODICE	Q.	DESCRIZIONE	DESIGNATION	BENENNUNG	DESCRIPTION	DENOMINACIONES
1	409586	2	RACCORDO	RACCORD	ANSCHLUSS	FITTING	RACOR
2	486700	2	TUBO FLESSIBILE	TUYAU FLEXIBLE	SCHLAUCH	FLEXIBLE HOSE	TUBO FLEXIBLE
3	410093	2	RACCORDO	RACCORD	ANSCHLUSS	FITTING	RACOR
4	409748	2	RACCORDO	RACCORD	ANSCHLUSS	FITTING	RACOR
5	495561	1	VALVOLA - DANFOSS	SOUPAPE - DANFOSS	VENTIL - DANFOSS	VALVE - DANFOSS	VALVULA - DANFOSS
6	497332	2	VITE	VIS	SCHRAUBE	SCREW	TORNILLO
7	409744	2	RACCORDO	RACCORD	ANSCHLUSS	FITTING	RACOR
8	417024	2	RONDELLA	RONDELLE	SCHEIBE	WASHER	ARANDELA
9	465879	1	SUPPORTO	SUPPORT	TRÄGER	SUPPORT	SOPORTE
10	207096	3	FASCETTA	COLLIER	HALTEBAND	CLAMP	ABRAZADERA
11	208220	1	FERMO	ARRET	VERSTELLVORRICHTUNG	LOCK	TOPE
12	409617	2	RACCORDO	RACCORD	ANSCHLUSS	FITTING	RACOR
13	460078	1	TUBO RIGIDO	TUYAU RIGIDE	ROHR	PIPE	TUBO RIGIDO
14	460079	1	TUBO RIGIDO	TUYAU RIGIDE	ROHR	PIPE	TUBO RIGIDO
15	409610	2	RACCORDO	RACCORD	ANSCHLUSS	FITTING	RACOR
16	495565	1	VALVOLA - HYDROCONTROL	SOUPAPE - HYDROCONTROL	VENTIL - HYDROCONTROL	VALVE - HYDROCONTROL	VALVULA - HYDROCONTROL



COMANDO MARTINETTO PRINCIPALE - HYDROCONTROL (21)

- * *Commande vérin principal - HYDROCONTROL*
- * *Hauptzylindersteuerung - HYDROCONTROL*
- * *Main cylinder control - HYDROCONTROL*
- * *Mando cilindro principal - HYDROCONTROL*

TAV. GK.05.01

matr. G107.0005

21
23 P

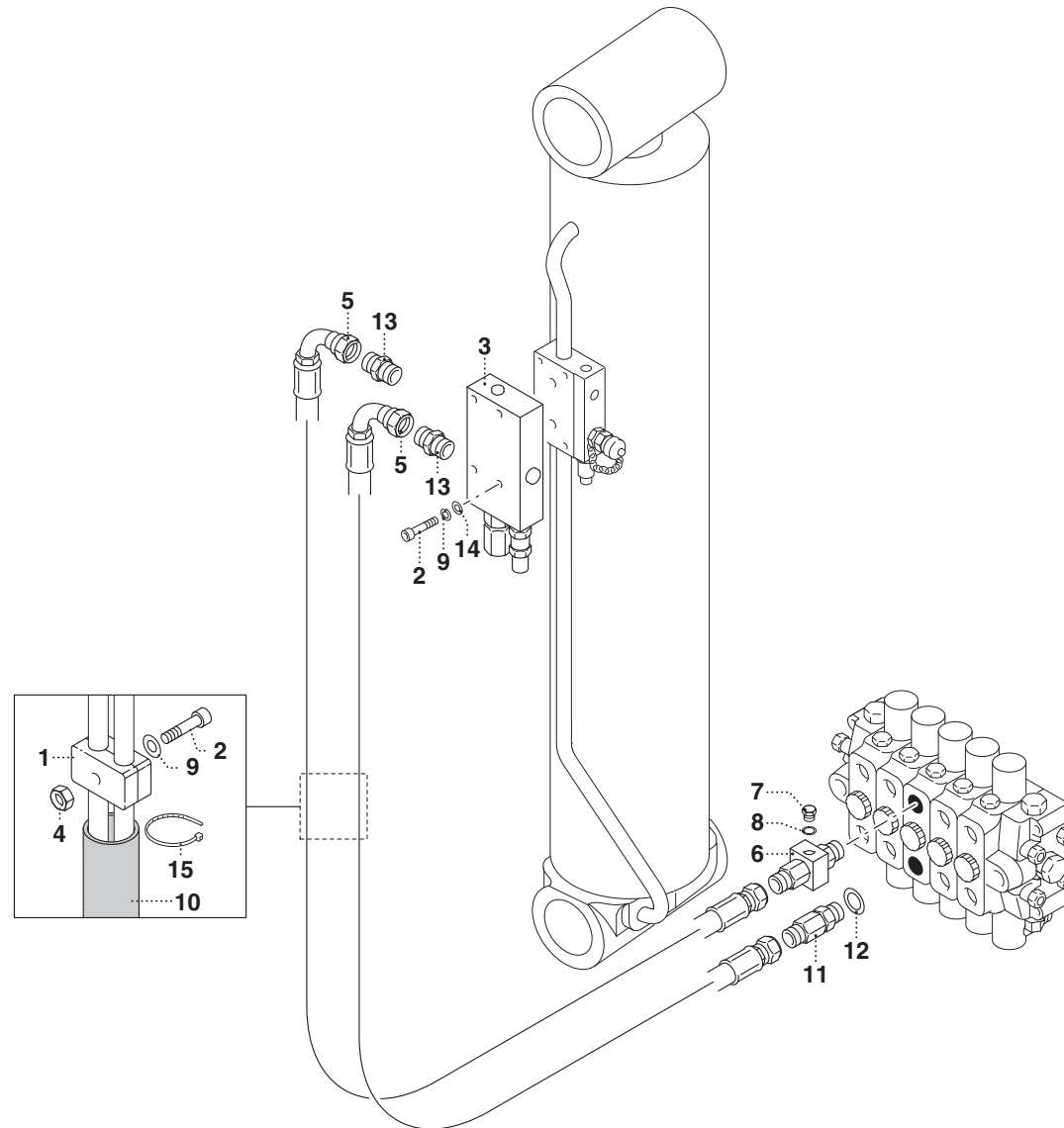
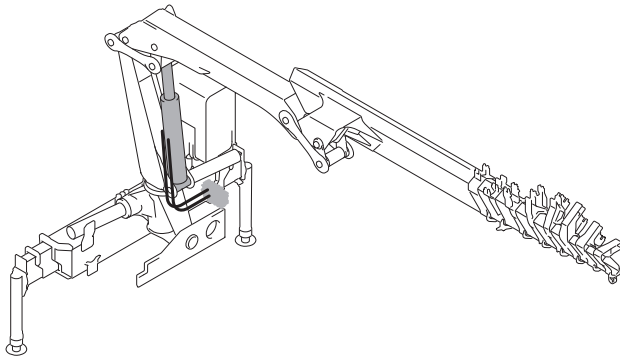

PM 21**matr. G107.0005****TAV. GK.05.01**

POS.	N° CODICE	Q.	DESCRIZIONE	DESIGNATION	BENENNUNG	DESCRIPTION	DENOMINACIONES
1	353073	1	MORSETTO	ETAU	KLEMME	CLAMP	PRENSOR
2	497137	5	VITE	VIS	SCHRAUBE	SCREW	TORNILLO
3	495471	1	VALVOLA	SOUPAPE	VENTIL	VALVE	VALVULA
4	191168	1	DADO	ECROU	MUTTER	NUT	TUERCA
5	482351	2	TUBO FLESSIBILE	TUYAU FLEXIBLE	SCHLAUCH	FLEXIBLE HOSE	TUBO FLEXIBLE
6	239010	1	RACCORDO	RACCORD	ANSCHLUSS	FITTING	RACOR
7	471019	1	TAPPO	BOUCHON	VERSCHLUSSDECKEL	PLUG	TAPON
8	417091	1	RONDELLA	RONDELLE	SCHEIBE	WASHER	ARANDELA
9	417025	5	RONDELLA	RONDELLE	SCHEIBE	WASHER	ARANDELA
10	276059	2	GUAINA	GAINÉ	MANTEL	SHEATH	VAINA
11	239268	1	RACCORDO	RACCORD	ANSCHLUSS	FITTING	RACOR
12	417092	1	RONDELLA	RONDELLE	SCHEIBE	WASHER	ARANDELA
13	409586	2	RACCORDO	RACCORD	ANSCHLUSS	FITTING	RACOR
14	417228	1	RONDELLA	RONDELLE	SCHEIBE	WASHER	ARANDELA
15	207094	4	FASCETTA	COLLIER	HALTEBAND	CLAMP	ABRAZADERA



COMANDO MARTINETTO PRINCIPALE - DANFOSS

- * *Commande vérin principal - DANFOSS*
- * *Hauptzylindersteuerung - DANFOSS*
- * *Main cylinder control - DANFOSS*
- * *Mando cilindro principal - DANFOSS*

TAV. GK.05.02

matr. G107.0005

21
23 P

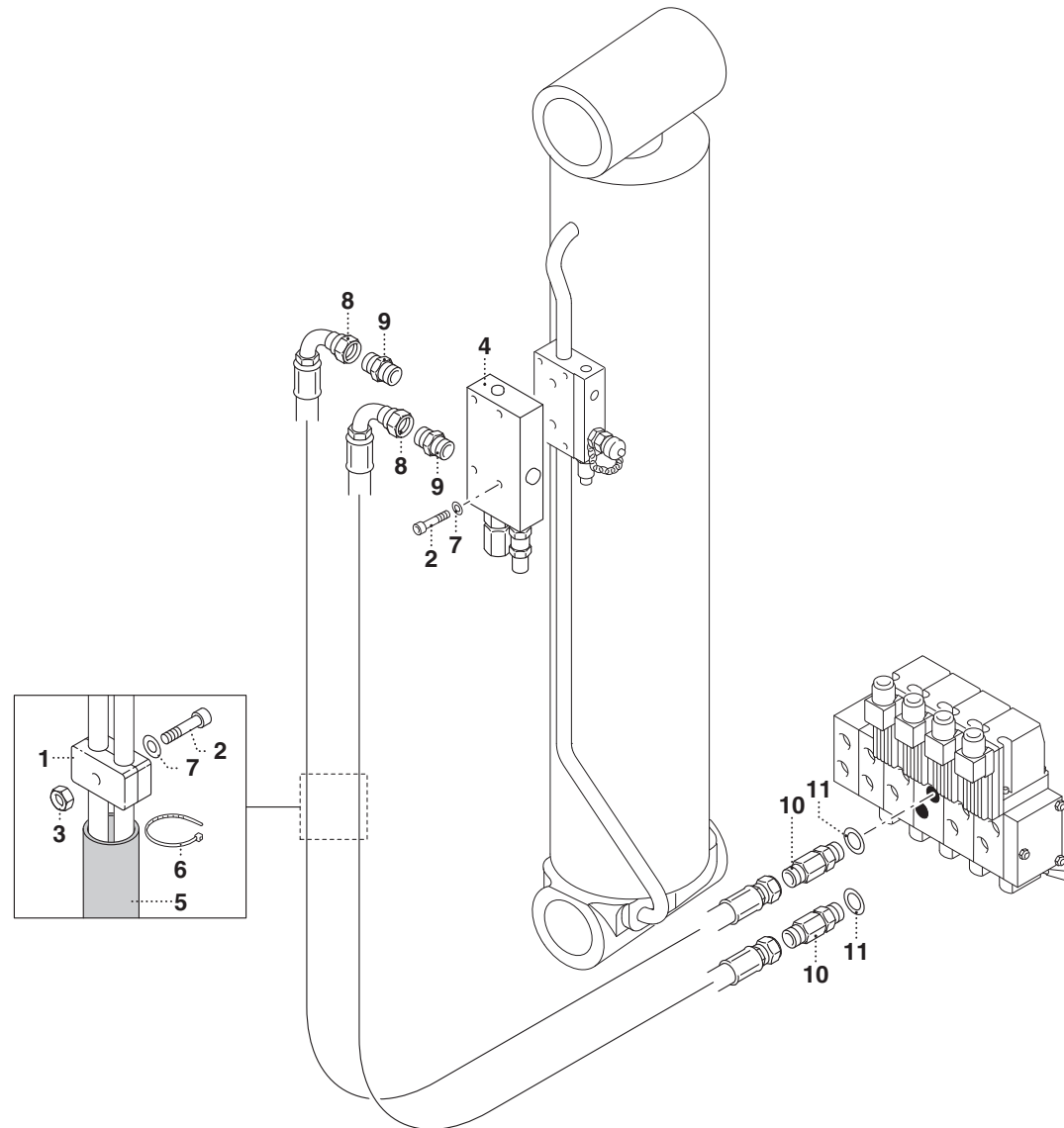
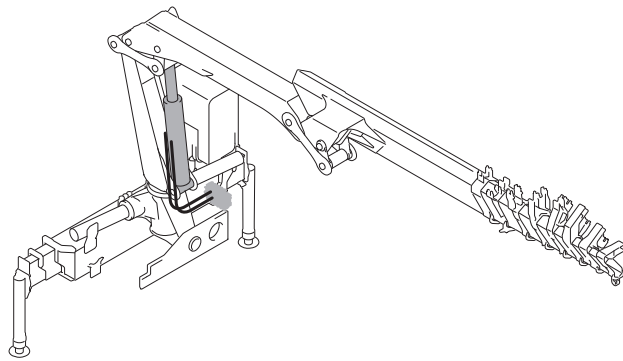



COMANDO MARTINETTO SECONDARIO - HYDROCONTROL (21)

- * *Commande vérin secondaire - HYDROCONTROL*
- * *Nebenzylindersteuerung - HYDROCONTROL*
- * *Secondary cylinder control - HYDROCONTROL*
- * *Mando cilindro secundario - HYDROCONTROL*

TAV. GK.06.01

matr. G107.0005

21
23 P

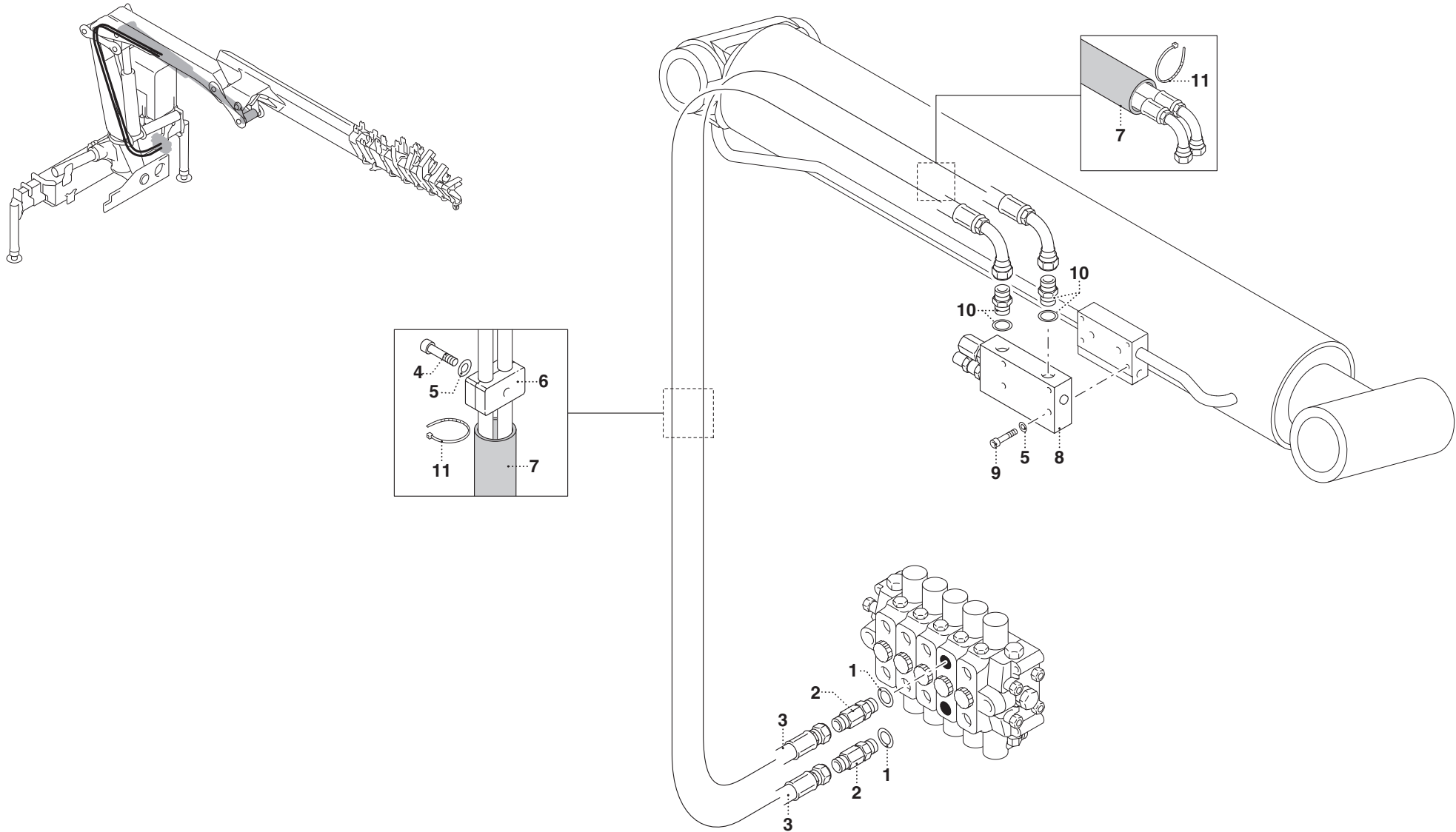



COMANDO MARTINETTO SECONDARIO - DANFOSS

- * *Commande vérin secondaire - DANFOSS*
- * *Nebenzylindersteuerung - DANFOSS*
- * *Secondary cylinder control - DANFOSS*
- * *Mando cilindro secundario - DANFOSS*

TAV. GK.06.02

matr. G107.0005

21
23 P

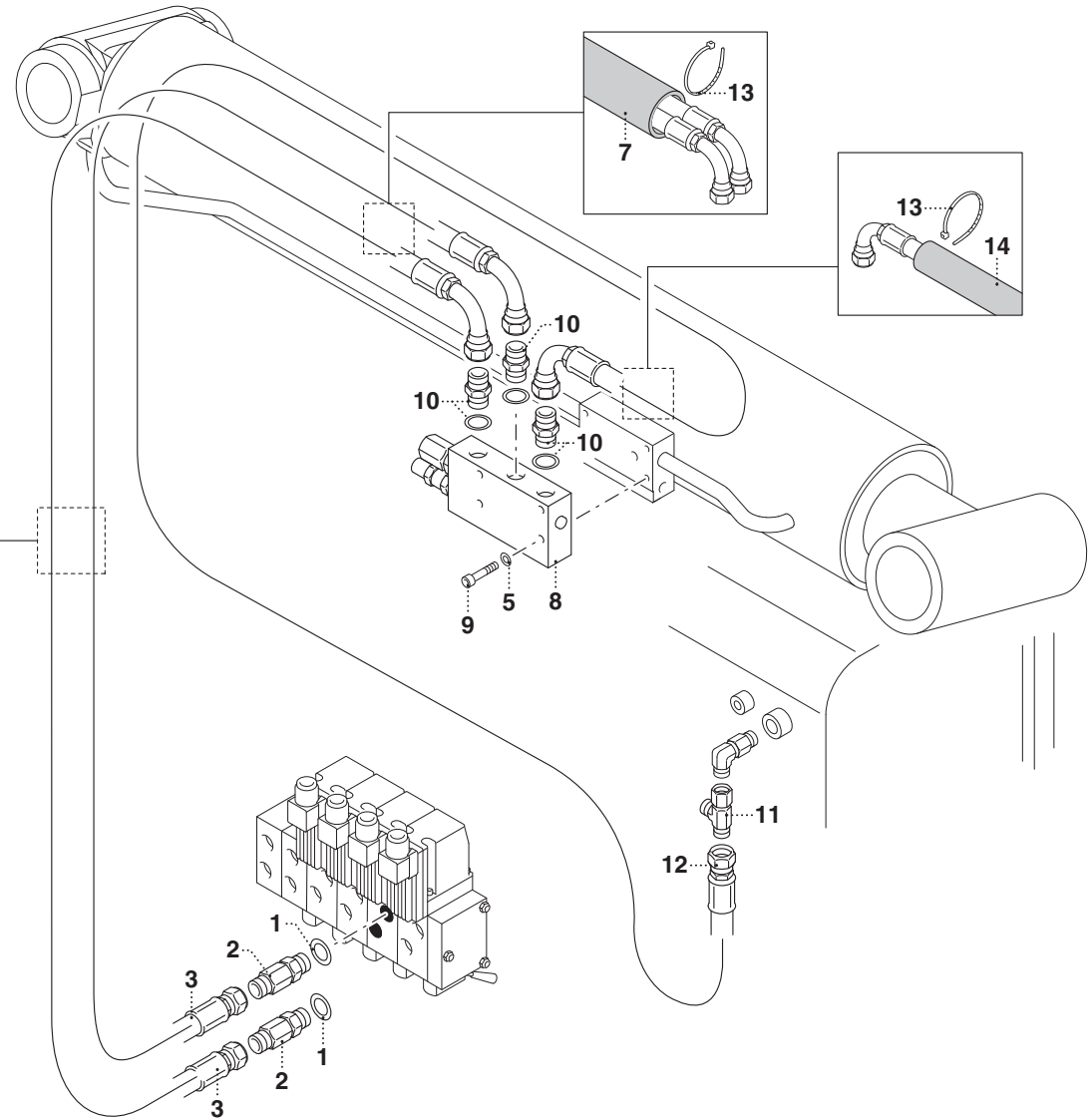
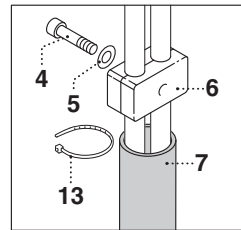
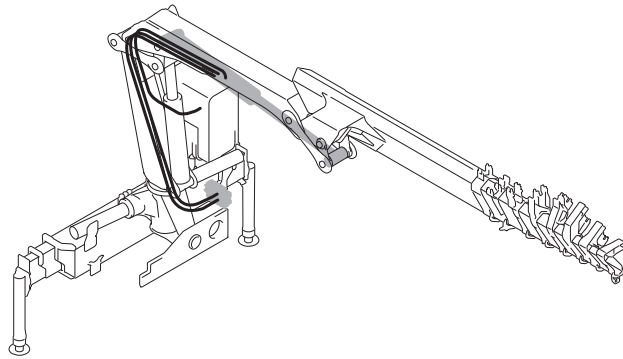

PM 21 - PM 23 P**matr. G107.0005****TAV. GK.06.02**

POS.	N° CODICE	Q.	DESCRIZIONE	DESIGNATION	BENENNUNG	DESCRIPTION	DENOMINACIONES
1	417092	2	RONDELLA	RONDELLE	SCHEIBE	WASHER	ARANDELA
2	239268	2	RACCORDO	RACCORD	ANSCHLUSS	FITTING	RACOR
3	482510	2	TUBO FLESSIBILE	TUYAU FLEXIBLE	SCHLAUCH	FLEXIBLE HOSE	TUBO FLEXIBLE
4	497134	2	VITE	VIS	SCHRAUBE	SCREW	TORNILLO
5	417025	6	RONDELLA	RONDELLE	SCHEIBE	WASHER	ARANDELA
6	353073	2	MORSETTO	ETAU	KLEMME	CLAMP	PRENSOR
7	276059	2	GUAINA	GAINÉ	MANTEL	SHEATH	VAINA
8	495613	1	VALVOLA	SOUPAPE	VENTIL	VALVE	VALVULA
9	497137	4	VITE	VIS	SCHRAUBE	SCREW	TORNILLO
10	409586	3	RACCORDO	RACCORD	ANSCHLUSS	FITTING	RACOR
11	409390	1	RACCORDO	RACCORD	ANSCHLUSS	FITTING	RACOR
12	482349	1	TUBO FLESSIBILE	TUYAU FLEXIBLE	SCHLAUCH	FLEXIBLE HOSE	TUBO FLEXIBLE
13	207064	8	FASCETTA	COLLIER	HALTEBAND	CLAMP	ABRAZADERA
14	276098	2	GUAINA	GAINÉ	MANTEL	SHEATH	VAINA
15	207064	8	FASCETTA	COLLIER	HALTEBAND	CLAMP	ABRAZADERA



COMANDO MARTINETTO SFILÒ BRACCI IDRAULICI - HYDROCONTROL (21)

- * *Commande vérin extension bras hydrauliques - HYDROCONTROL*
- * *Hydraulische arme Ausziehzylindersteuerung - HYDROCONTROL*
- * *Hydraulic arms extension cylinder control - HYDROCONTROL*
- * *Mando cilindro extensión brazos hidráulicos - HYDROCONTROL*

TAV. GK.07.01

matr. G107.0005

21
23 P

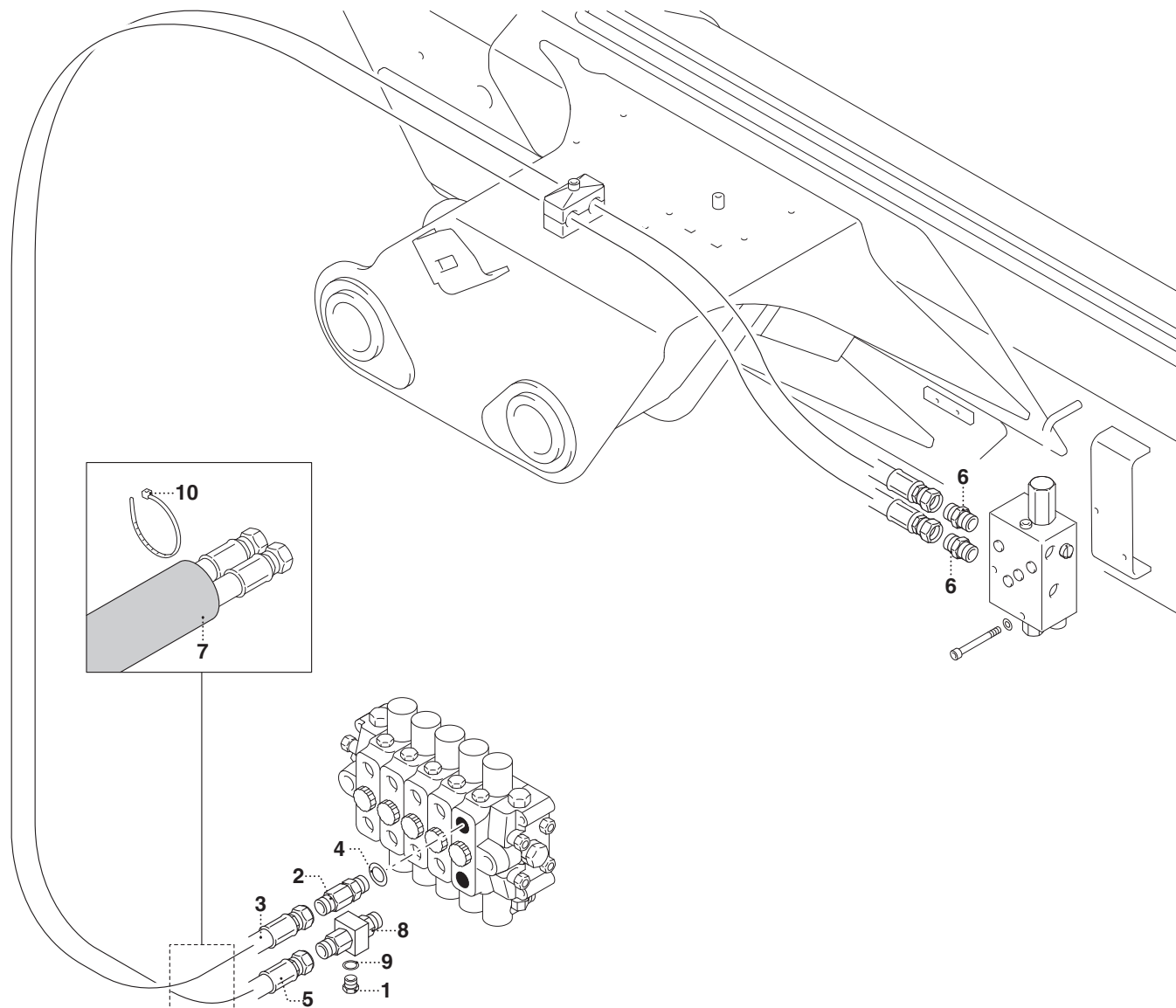
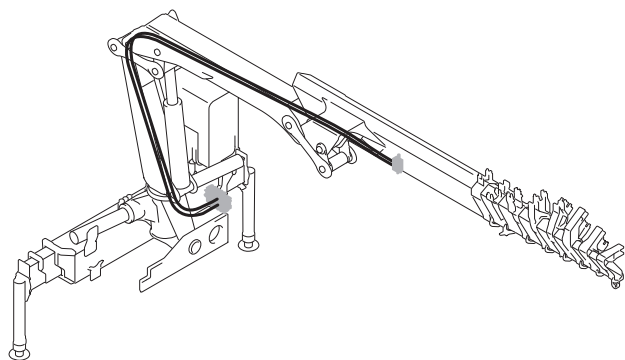



COMANDO MARTINETTO SFILÒ BRACCI IDRAULICI - DANFOSS

- * *Commande vérin extension bras hydrauliques - DANFOSS*
- * *Hydraulicarme Ausziehzylindersteuerung - DANFOSS*
- * *Hydraulic arms extension cylinder control - DANFOSS*
- * *Mando cilindro extensión brazos hidráulicos - DANFOSS*

TAV. GK.07.02

matr. G107.0005

21
23 P

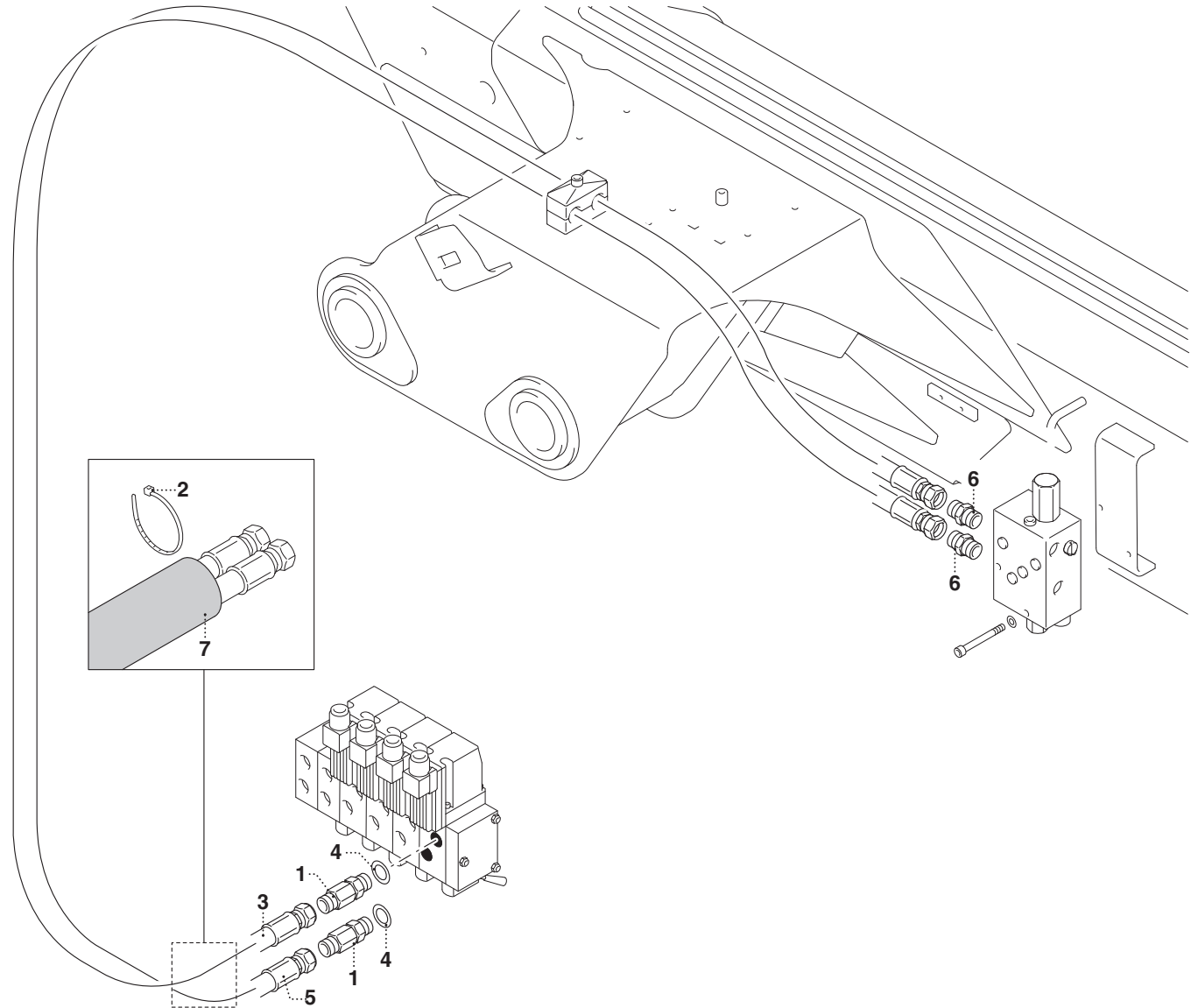
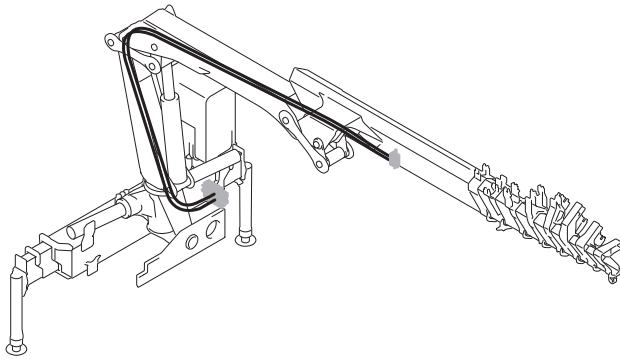

PM 21 - PM 23 P

matr. G107.0005

TAV. GK.07.02

POS.	N° CODICE	Q.	DESCRIZIONE	DESIGNATION	BENENNUNG	DESCRIPTION	DENOMINACIONES
1	239268	2	RACCORDO	RACCORD	ANSCHLUSS	FITTING	RACOR
2	207064	4	FASCETTA	COLLIER	HALTEBAND	CLAMP	ABRAZADERA
3	482511	1	TUBO FLESSIBILE	TUYAU FLEXIBLE	SCHLAUCH	FLEXIBLE HOSE	TUBO FLEXIBLE
4	417092	2	RONDELLA	RONDELLE	SCHEIBE	WASHER	ARANDELA
5	482512	1	TUBO FLESSIBILE	TUYAU FLEXIBLE	SCHLAUCH	FLEXIBLE HOSE	TUBO FLEXIBLE
6	409586	2	RACCORDO	RACCORD	ANSCHLUSS	FITTING	RACOR
7	276059	2	GUAINA	GAINÉ	MANTEL	SHEATH	VAINA



COMANDO MARTINETTO SFILÒ BRACCI IDRAULICI - HYDROCONTROL - 3° PUNTO DI MANOVRA (21)

- * Commande vérin extension bras hydrauliques - HYDROCONTROL - 3ème point de manœuvre
- * Hydraulischearme Ausziehzylindersteuerung - HYDROCONTROL - 3. Manöverplatz
- * Hydraulic arms extension cylinder control - HYDROCONTROL - 3rd manoeuvre position
- * Mando cilindro extensión brazos hidráulicos - HYDROCONTROL - 3er punto de maniobra

TAV. GK.07.03

matr. G107.0005

21
23 P

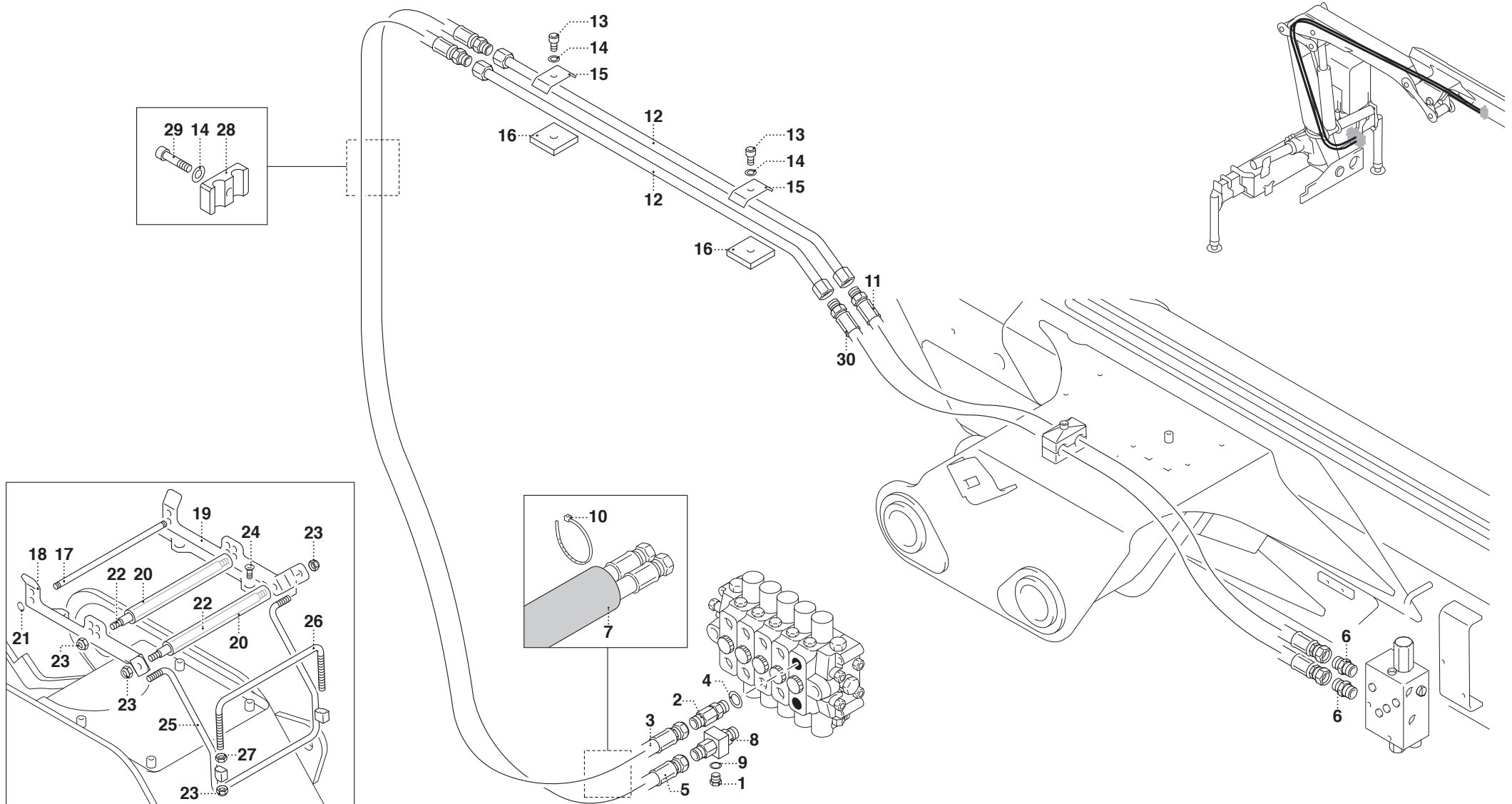

PM 21**matr. G107.0005****TAV. GK.07.03**

POS.	N° CODICE	Q.	DESCRIZIONE	DESIGNATION	BENENNUNG	DESCRIPTION	DENOMINACIONES
1	471019	1	TAPPO	BOUCHON	VERSCHLUSSDECKEL	PLUG	TAPON
2	239268	1	RACCORDO	RACCORD	ANSCHLUSS	FITTING	RACOR
3	482601	1	TUBO FLESSIBILE	TUYAU FLEXIBLE	SCHLAUCH	FLEXIBLE HOSE	TUBO FLEXIBLE
4	417092	1	RONDELLA	RONDELLE	SCHEIBE	WASHER	ARANDELA
5	482603	1	TUBO FLESSIBILE	TUYAU FLEXIBLE	SCHLAUCH	FLEXIBLE HOSE	TUBO FLEXIBLE
6	409586	2	RACCORDO	RACCORD	ANSCHLUSS	FITTING	RACOR
7	276059	2	GUAINA	GAINÉ	MANTEL	SHEATH	VAINA
8	239010	1	RACCORDO	RACCORD	ANSCHLUSS	FITTING	RACOR
9	417091	1	RONDELLA	RONDELLE	SCHEIBE	WASHER	ARANDELA
10	207064	4	FASCETTA	COLLIER	HALTEBAND	CLAMP	ABRAZADERA
11	482604	1	TUBO FLESSIBILE	TUYAU FLEXIBLE	SCHLAUCH	FLEXIBLE HOSE	TUBO FLEXIBLE
12	460339	2	TUBO RIGIDO	TUYAU RIGIDE	ROHR	PIPE	TUBO RIGIDO
13	497132	2	VITE	VIS	SCHRAUBE	SCREW	TORNILLO
14	417025	3	RONDELLA	RONDELLE	SCHEIBE	WASHER	ARANDELA
15	353099	2	MORSETTO	ETAU	KLEMME	CLAMP	PRENSOR
16	262170	2	SPESSORE	EPAISSEUR	DICKE	THICKNESS	ESPEJOR
17	467855	1	SUPPORTO	SUPPORT	TRÄGER	SUPPORT	SOPORTE
18	467852	1	SUPPORTO	SUPPORT	TRÄGER	SUPPORT	SOPORTE
19	467854	1	SUPPORTO	SUPPORT	TRÄGER	SUPPORT	SOPORTE
20	429086	2	RULLO	GALET	ROLLE	ROLLER	RODILLO
21	109001	2	ANELLO ELASTICO	JOINT D'ARRET	SPRENGRING	SPRING RING	ANILLO ELASTICO
22	380594	2	PERNO	AXE	BOLZEN	PIN	PERNO
23	191045	8	DADO	ECROU	MUTTER	NUT	TUERCA
24	497249	4	VITE	VIS	SCHRAUBE	SCREW	TORNILLO
25	467853	1	SUPPORTO	SUPPORT	TRÄGER	SUPPORT	SOPORTE
26	315649	1	FERMO	ARRET	VERSTELLVORRICHTUNG	LOCK	TOPE



COMANDO MARTINETTO SFILÒ BRACCI IDRAULICI - DANFOSS - 3° PUNTO DI MANOVRA

* *Commande vérin extension bras hydrauliques - DANFOSS - 3ème point de manœuvre*

* *Hydraulicarme Ausziehzylindersteuerung - DANFOSS - 3. Manöverplatz*

* *Hydraulic arms extension cylinder control - DANFOSS - 3rd manoeuvre position*

* *Mando cilindro extensión brazos hidráulicos - DANFOSS - 3er punto de maniobra*

TAV. GK.07.04

matr. G107.0005

21
23 P

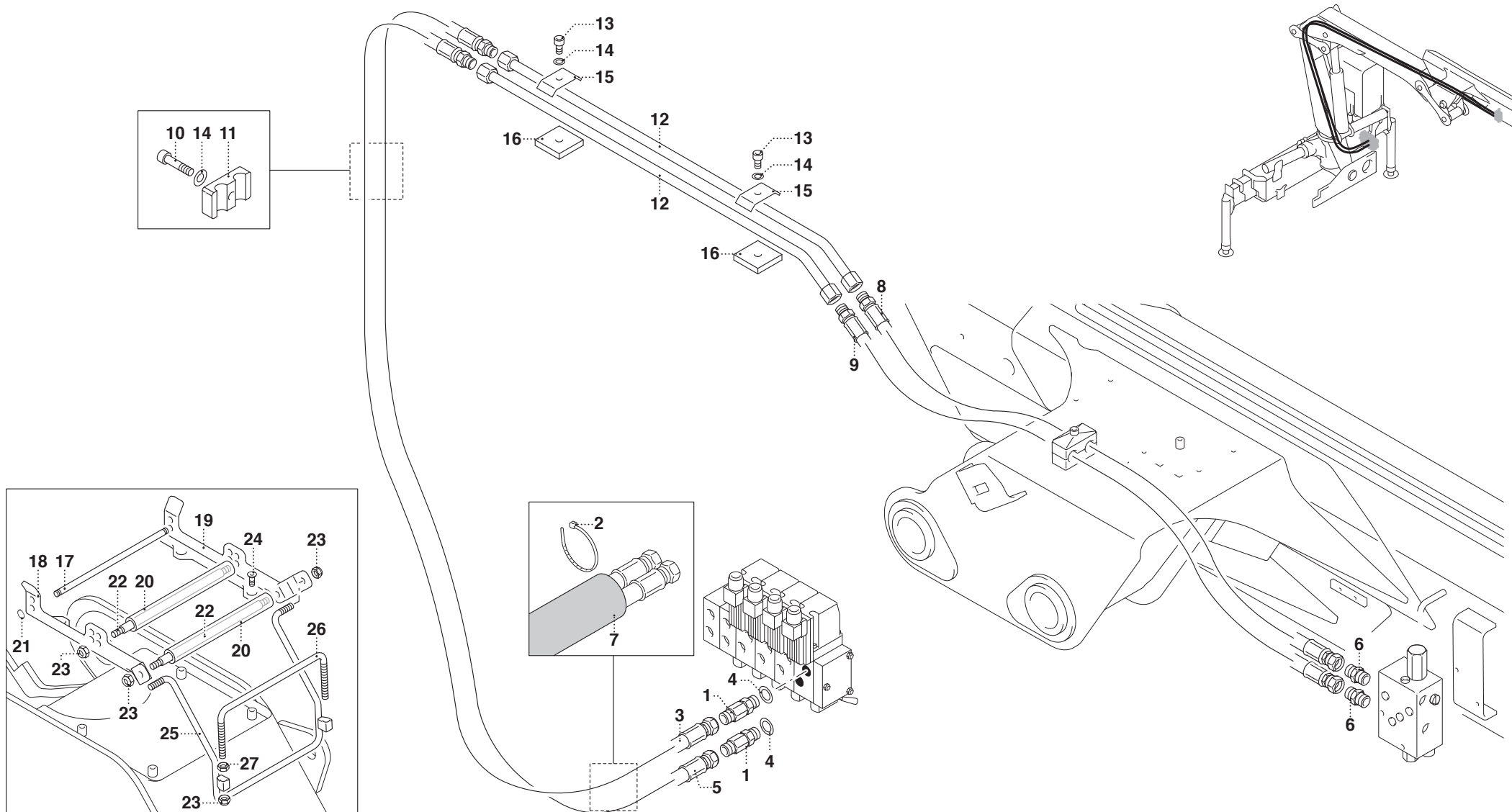

PM 21 - PM 23 P

matr. G107.0005

TAV. GK.07.04

POS.	N° CODICE	Q.	DESCRIZIONE	DESIGNATION	BENENNUNG	DESCRIPTION	DENOMINACIONES
1	239268	2	RACCORDO	RACCORD	ANSCHLUSS	FITTING	RACOR
2	207064	4	FASCETTA	COLLIER	HALTEBAND	CLAMP	ABRAZADERA
3	482601	1	TUBO FLESSIBILE	TUYAU FLEXIBLE	SCHLAUCH	FLEXIBLE HOSE	TUBO FLEXIBLE
4	417092	2	RONDELLA	RONDELLE	SCHEIBE	WASHER	ARANDELA
5	482603	1	TUBO FLESSIBILE	TUYAU FLEXIBLE	SCHLAUCH	FLEXIBLE HOSE	TUBO FLEXIBLE
6	409586	2	RACCORDO	RACCORD	ANSCHLUSS	FITTING	RACOR
7	276059	2	GUAINA	GAINÉ	MANTEL	SHEATH	VAINA
8	482604	1	TUBO FLESSIBILE	TUYAU FLEXIBLE	SCHLAUCH	FLEXIBLE HOSE	TUBO FLEXIBLE
9	482602	1	TUBO FLESSIBILE	TUYAU FLEXIBLE	SCHLAUCH	FLEXIBLE HOSE	TUBO FLEXIBLE
10	497134	1	VITE	VIS	SCHRAUBE	SCREW	TORNILLO
11	353079	1	MORSETTO	ETAU	KLEMME	CLAMP	PRENSOR
12	460339	2	TUBO RIGIDO	TUYAU RIGIDE	ROHR	PIPE	TUBO RIGIDO
13	497132	2	VITE	VIS	SCHRAUBE	SCREW	TORNILLO
14	417025	3	RONDELLA	RONDELLE	SCHEIBE	WASHER	ARANDELA
15	353099	2	MORSETTO	ETAU	KLEMME	CLAMP	PRENSOR
16	262170	2	SPESSORE	EPAISSEUR	DICKE	THICKNESS	ESPEJOR
17	467855	1	SUPPORTO	SUPPORT	TRÄGER	SUPPORT	SOPORTE
18	467852	1	SUPPORTO	SUPPORT	TRÄGER	SUPPORT	SOPORTE
19	467854	1	SUPPORTO	SUPPORT	TRÄGER	SUPPORT	SOPORTE
20	429086	2	RULLO	GALET	ROLLE	ROLLER	RODILLO
21	109001	2	ANELLO ELASTICO	JOINT D'ARRET	SPRENGRING	SPRING RING	ANILLO ELASTICO
22	380594	2	PERNO	AXE	BOLZEN	PIN	PERNO
23	191045	8	DADO	ECROU	MUTTER	NUT	TUERCA
24	497249	4	VITE	VIS	SCHRAUBE	SCREW	TORNILLO
25	467853	1	SUPPORTO	SUPPORT	TRÄGER	SUPPORT	SOPORTE
26	315649	1	FERMO	ARRET	VERSTELLVORRICHTUNG	LOCK	TOPE



COMANDO MARTINETTO SFILÒ BRACCI IDRAULICI - DANFOSS - 3° PUNTO DI MANOVRA

- * *Commande vérin extension bras hydrauliques - DANFOSS - 3ème point de manœuvre*
- * *Hydraulicarme Ausziehzylindersteuerung - DANFOSS - 3. Manöverplatz*
- * *Hydraulic arms extension cylinder control - DANFOSS - 3rd manoeuvre position*
- * *Mando cilindro extensión brazos hidráulicos - DANFOSS - 3er punto de maniobra*

TAV. GK.07.04

matr. G107.0005

21
23 P

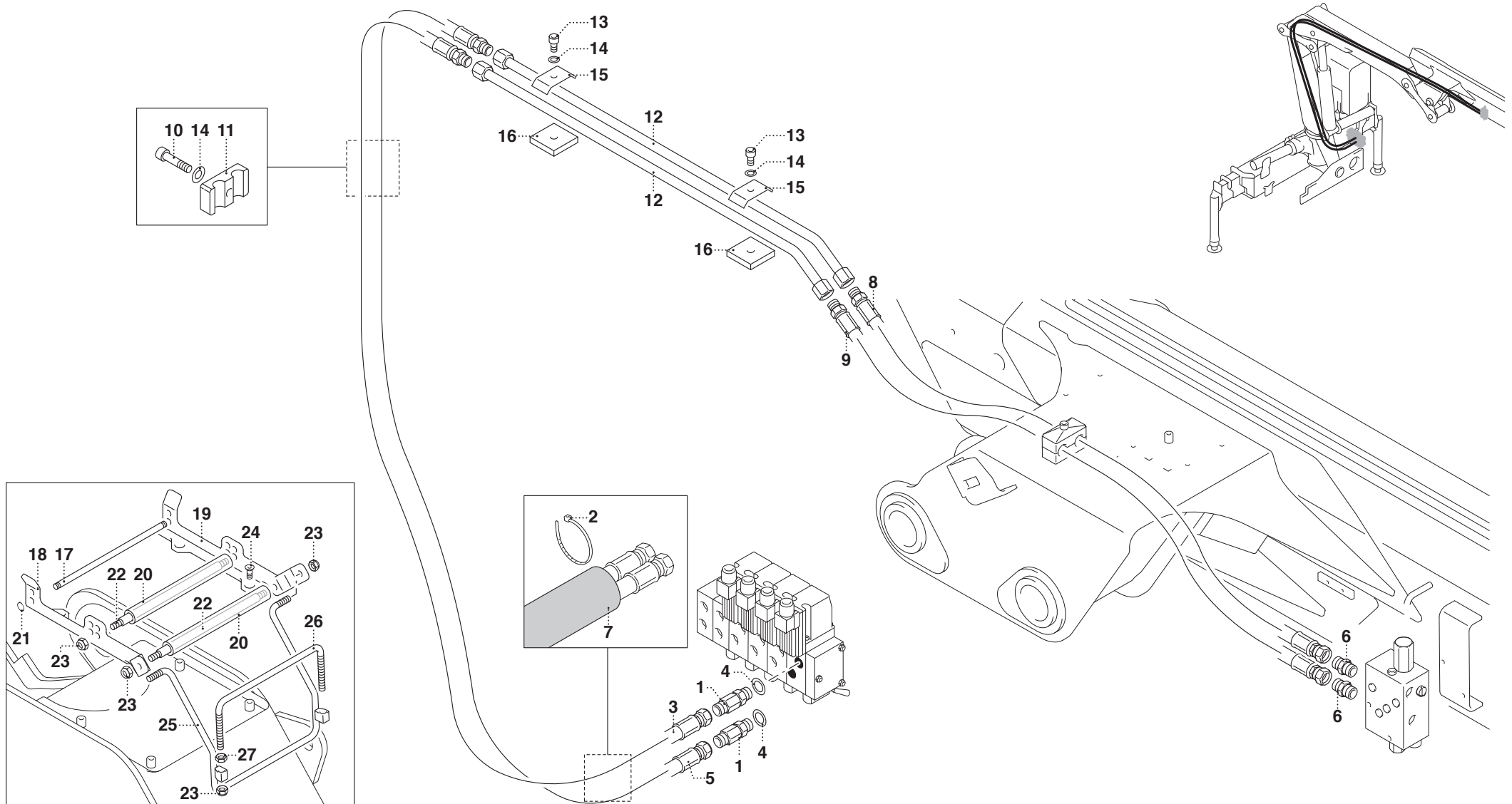



COMPL. COMANDO MARTINETTO SFILÒ BRACCI IDRAULICI (SECONDARIO/1°/2°) (LC)

- * Compl. commande vérin extension bras hydrauliques (secondaire/1er/2ème) (LC)
- * Ergänzung des Steuerungs der Hydraulischearmeausziehzylinder (Neben/1./2.) (LC)
- * Hydraulic arms extension cylinder control - compl. (secondary/1st/2nd) (LC)
- * Complet. mando cilindro extensión brazos hidráulicos (secundario/1ro/2do) (LC)

TAV. GL.01.01 1/2

matr. G107.0005

21
23 P

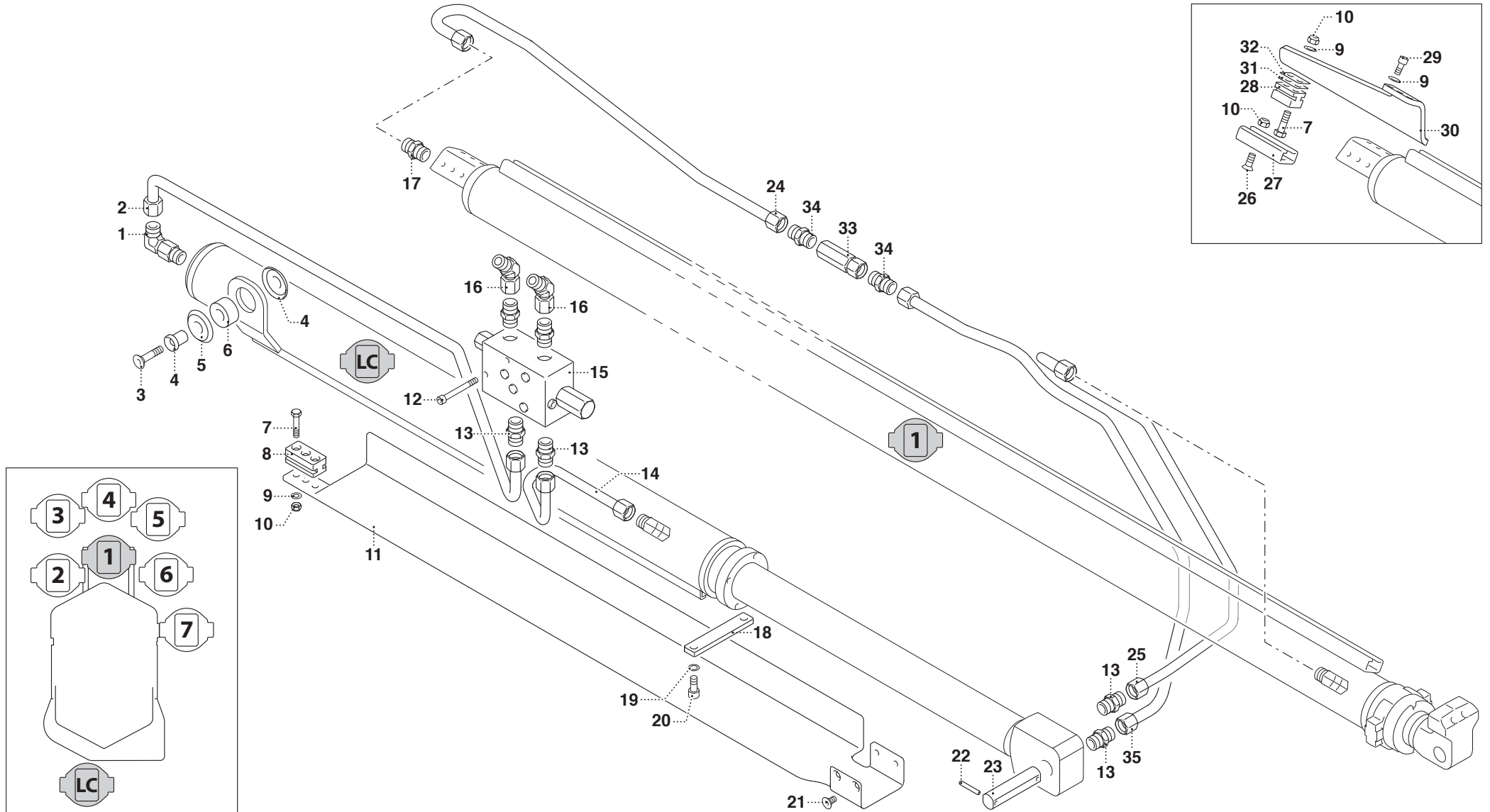

UN01-R-1648-LI

UNISTUDIO - Modena

PM 21 LC - PM 23 P LC

matr. G107.0005

TAV. GL.01.01 1/2

POS.	N° CODICE	Q.	DESCRIZIONE	DESIGNATION	BENENNUNG	DESCRIPTION	DENOMINACIONES
1	409595	1	RACCORDO	RACCORD	ANSCHLUSS	FITTING	RACOR
2	460242	1	TUBO RIGIDO	TUYAU RIGIDE	ROHR	PIPE	TUBO RIGIDO
3	497392	1	VITE	VIS	SCHRAUBE	SCREW	TORNILLO
4	466508	1	SUPPORTO	SUPPORT	TRÄGER	SUPPORT	SOPORTE
5	262010	1	TAMPONE	PARE-COUPS	ANSCHLAGPUFFER	BUFFER	AMORTIGUADOR
6	417144	2	RONDELLA	RONDELLE	SCHEIBE	WASHER	ARANDELA
7	497029	5	VITE	VIS	SCHRAUBE	SCREW	TORNILLO
8	373926	1	PATTINO	PATIN	GLEITBLOCK	SLIDING BLOCK	PATIN
9	417004	8	RONDELLA	RONDELLE	SCHEIBE	WASHER	ARANDELA
10	191168	9	DADO	ECROU	MUTTER	NUT	TUERCA
11	403271	1	PROTEZIONE	PROTECTION	SCHUTZ	GUARD	PROTECCION
12	497966	2	VITE	VIS	SCHRAUBE	SCREW	TORNILLO
13	409586	4	RACCORDO	RACCORD	ANSCHLUSS	FITTING	RACOR
14	460243	1	TUBO RIGIDO	TUYAU RIGIDE	ROHR	PIPE	TUBO RIGIDO
15	495541	1	VALVOLA	SOUPAPE	VENTIL	VALVE	VALVULA
16	409744	2	RACCORDO	RACCORD	ANSCHLUSS	FITTING	RACOR
17	410386	1	RACCORDO	RACCORD	ANSCHLUSS	FITTING	RACOR
18	208190	1	FERMO	ARRET	VERSTELLVORRICHTUNG	LOCK	TOPE
19	417026	2	RONDELLA	RONDELLE	SCHEIBE	WASHER	ARANDELA
20	497145	2	VITE	VIS	SCHRAUBE	SCREW	TORNILLO
21	497131	2	VITE	VIS	SCHRAUBE	SCREW	TORNILLO
22	455221	2	SPINA	GOUPILLE	STIFT	PIN	PASADOR
23	380407	1	PERNO	AXE	BOLZEN	PIN	PERNO
24	460269	1	TUBO RIGIDO	TUYAU RIGIDE	ROHR	PIPE	TUBO RIGIDO
25	460244	1	TUBO RIGIDO	TUYAU RIGIDE	ROHR	PIPE	TUBO RIGIDO
26	497249	4	VITE	VIS	SCHRAUBE	SCREW	TORNILLO



COMPL. COMANDO MARTINETTO SFILÒ BRACCI IDRAULICI (SECONDARIO/1°/2°) (LC)

- * Compl. commande vérin extension bras hydrauliques (secondaire/1er/2ème) (LC)
- * Ergänzung des Steuerungs der Hydraulischearmeausziehzylinder (Neben/1./2.) (LC)
- * Hydraulic arms extension cylinder control - compl. (secondary/1st/2nd) (LC)
- * Complet. mando cilindro extensión brazos hidráulicos (secundario/1ro/2do) (LC)

TAV. GL.01.01A 1/2

matr. G107.0069

21
23 P

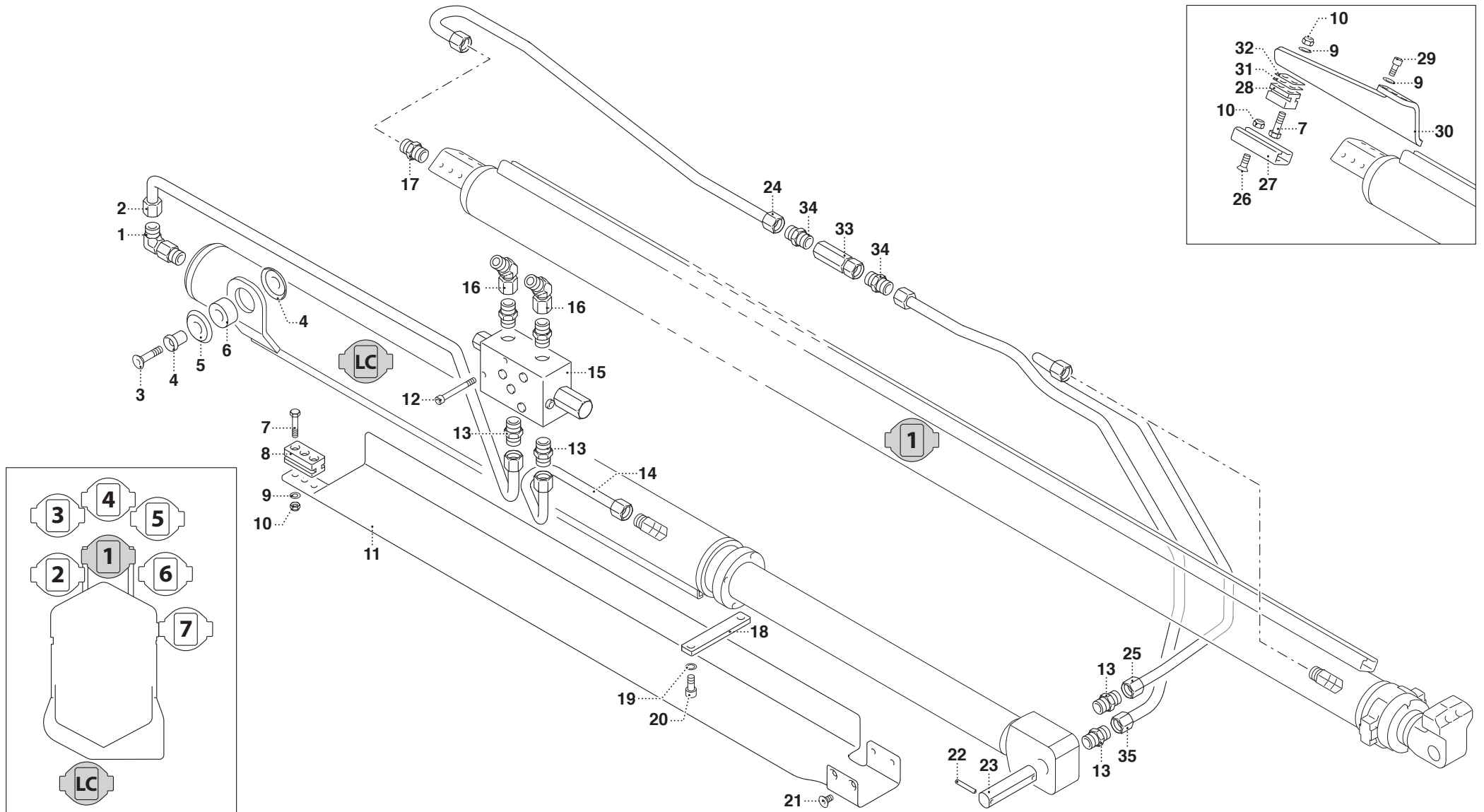

UN01-R-1648-LI

PM 21 LC - PM 23 P LC

matr. G107.0069

TAV. GL.01.01A 1/2

POS.	N° CODICE	Q.	DESCRIZIONE	DESIGNATION	BENENNUNG	DESCRIPTION	DENOMINACIONES
1	409595	1	RACCORDO	RACCORD	ANSCHLUSS	FITTING	RACOR
2	460358	1	TUBO RIGIDO	TUYAU RIGIDE	ROHR	PIPE	TUBO RIGIDO
3	497392	1	VITE	VIS	SCHRAUBE	SCREW	TORNILLO
4	466508	1	SUPPORTO	SUPPORT	TRÄGER	SUPPORT	SOPORTE
5	262010	1	TAMPONE	PARE-COUPS	ANSCHLAGPUFFER	BUFFER	AMORTIGUADOR
6	417144	2	RONDELLA	RONDELLE	SCHEIBE	WASHER	ARANDELA
7	497029	5	VITE	VIS	SCHRAUBE	SCREW	TORNILLO
8	373926	1	PATTINO	PATIN	GLEITBLOCK	SLIDING BLOCK	PATIN
9	417004	8	RONDELLA	RONDELLE	SCHEIBE	WASHER	ARANDELA
10	191168	9	DADO	ECROU	MUTTER	NUT	TUERCA
11	403276	1	PROTEZIONE	PROTECTION	SCHUTZ	GUARD	PROTECCION
12	497966	2	VITE	VIS	SCHRAUBE	SCREW	TORNILLO
13	409586	4	RACCORDO	RACCORD	ANSCHLUSS	FITTING	RACOR
14	460357	1	TUBO RIGIDO	TUYAU RIGIDE	ROHR	PIPE	TUBO RIGIDO
15	495541	1	VALVOLA	SOUPAPE	VENTIL	VALVE	VALVULA
16	409744	2	RACCORDO	RACCORD	ANSCHLUSS	FITTING	RACOR
17	410386	1	RACCORDO	RACCORD	ANSCHLUSS	FITTING	RACOR
18	208190	1	FERMO	ARRET	VERSTELLVORRICHTUNG	LOCK	TOPE
19	417026	2	RONDELLA	RONDELLE	SCHEIBE	WASHER	ARANDELA
20	497145	2	VITE	VIS	SCHRAUBE	SCREW	TORNILLO
21	497131	2	VITE	VIS	SCHRAUBE	SCREW	TORNILLO
22	455221	2	SPINA	GOUPILLE	STIFT	PIN	PASADOR
23	380407	1	PERNO	AXE	BOLZEN	PIN	PERNO
24	460269	1	TUBO RIGIDO	TUYAU RIGIDE	ROHR	PIPE	TUBO RIGIDO
25	460244	1	TUBO RIGIDO	TUYAU RIGIDE	ROHR	PIPE	TUBO RIGIDO
26	497249	4	VITE	VIS	SCHRAUBE	SCREW	TORNILLO



COMPL. COMANDO MARTINETTO SFILLO BRACCI IDRAULICI (SECONDARIO/1°/2°) (LC)

- * Compl. commande vérin extension bras hydrauliques (secondaire/1er/2ème) (LC)
- * Ergänzung des Steuerungs der Hydraulischearmeausziehzylinder (Neben/1./2.) (LC)
- * Hydraulic arms extension cylinder control - compl. (secondary/1st/2nd) (LC)
- * Complet. mando cilindro extensión brazos hidráulicos (secundario/1ro/2do) (LC)

TAV. GL.01.01A 1/2

matr. G107.0069

21
23 P

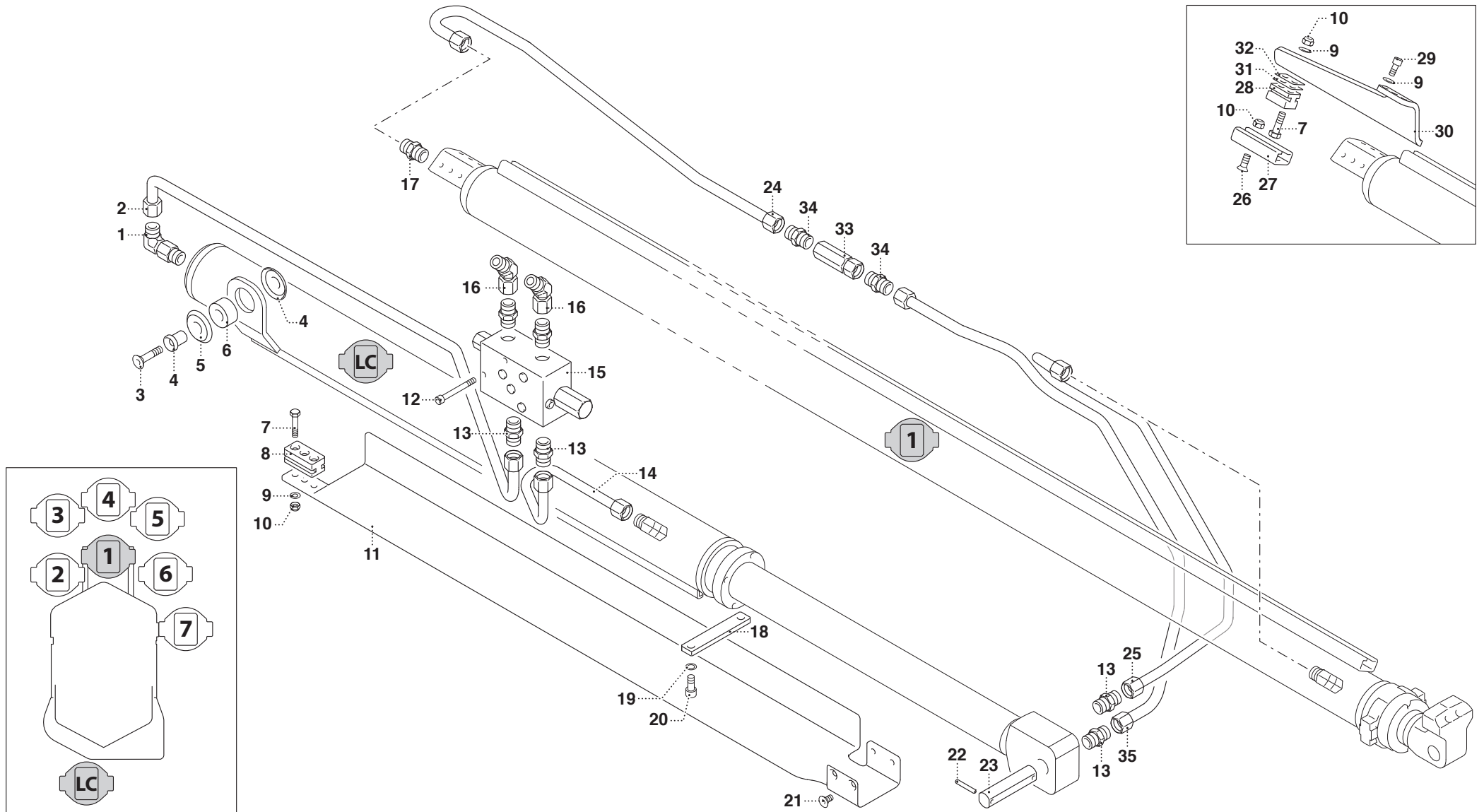

UN01-R-1648-LI

PM 21 LC - PM 23 P LC

matr. G107.0069

TAV. GL.01.01A 1/2

POS.	N° CODICE	Q.	DESCRIZIONE	DESIGNATION	BENENNUNG	DESCRIPTION	DENOMINACIONES
27	467060	1	SUPPORTO	SUPPORT	TRÄGER	SUPPORT	SOPORTE
28	373930	1	PATTINO	PATIN	GLEITBLOCK	SLIDING BLOCK	PATIN
29	497131	3	VITE	VIS	SCHRAUBE	SCREW	TORNILLO
30	467515	1	SUPPORTO	SUPPORT	TRÄGER	SUPPORT	SOPORTE
31	308012	1	SPESSORE	EPAISSEUR	DICKE	THICKNESS	ESPEJOR
32	308013	1	SPESSORE	EPAISSEUR	DICKE	THICKNESS	ESPEJOR
33	495562	1	VALVOLA	SOUPAPE	VENTIL	VALVE	VALVULA
34	409831	2	RACCORDO	RACCORD	ANSCHLUSS	FITTING	RACOR
35	460268	1	TUBO RIGIDO	TUYAU RIGIDE	ROHR	PIPE	TUBO RIGIDO



COMPL. COMANDO MARTINETTO SFILÒ BRACCI IDRAULICI (SECONDARIO/1°/2°) (LC)

- * Compl. commande vérin extension bras hydrauliques (secondaire/1er/2ème) (LC)
- * Ergänzung des Steuerungs der Hydraulischearmeausziehzylinder (Neben/1./2.) (LC)
- * Hydraulic arms extension cylinder control - compl. (secondary/1st/2nd) (LC)
- * Complet. mando cilindro extensión brazos hidráulicos (secundario/1ro/2do) (LC)

TAV. GL.01.01 2/2

matr. G107.0005

21
23 P

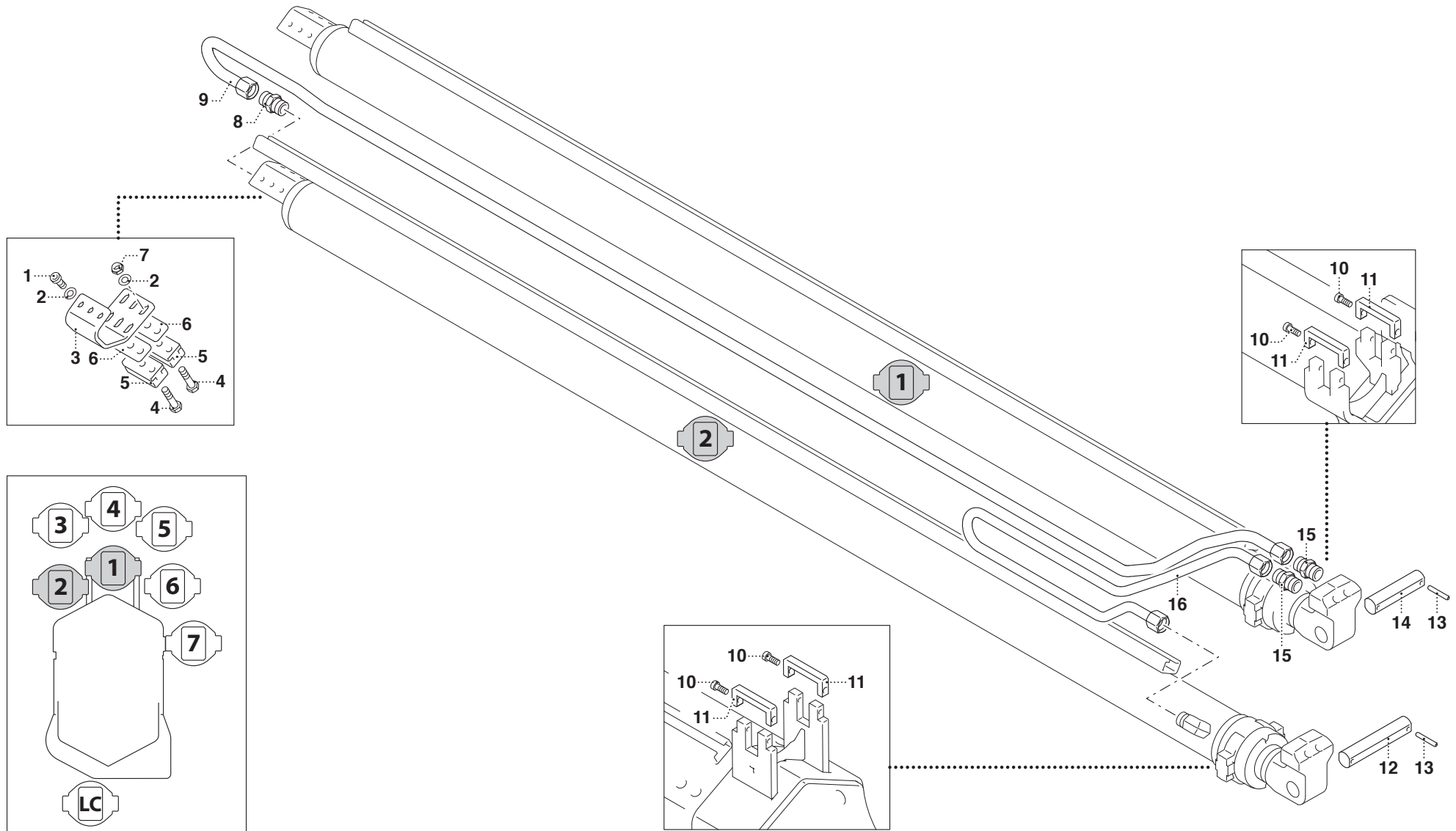

PM 21 LC - PM 23 P LC

matr. G107.0005

TAV. GL.01.01 2/2

POS.	N° CODICE	Q.	DESCRIZIONE	DESIGNATION	BENENNUNG	DESCRIPTION	DENOMINACIONES
1	497238	3	VITE	VIS	SCHRAUBE	SCREW	TORNILLO
2	417004	6	RONDELLA	RONDELLE	SCHEIBE	WASHER	ARANDELA
3	467521	1	SUPPORTO	SUPPORT	TRÄGER	SUPPORT	SOPORTE
4	497029	6	VITE	VIS	SCHRAUBE	SCREW	TORNILLO
5	373926	2	PATTINO	PATIN	GLEITBLOCK	SLIDING BLOCK	PATIN
6	308611	2	SPESSORE	EPAISSEUR	DICKE	THICKNESS	ESPEJOR
7	191168	3	DADO	ECROU	MUTTER	NUT	TUERCA
8	410386	1	RACCORDO	RACCORD	ANSCHLUSS	FITTING	RACOR
9	460082	1	TUBO RIGIDO	TUYAU RIGIDE	ROHR	PIPE	TUBO RIGIDO
10	497383	8	VITE	VIS	SCHRAUBE	SCREW	TORNILLO
11	467485	4	SUPPORTO	SUPPORT	TRÄGER	SUPPORT	SOPORTE
12	380461	1	PERNO	AXE	BOLZEN	PIN	PERNO
13	455221	4	SPINA	GOUPILLE	STIFT	PIN	PASADOR
14	380407	1	PERNO	AXE	BOLZEN	PIN	PERNO
15	409586	2	RACCORDO	RACCORD	ANSCHLUSS	FITTING	RACOR
16	460083	1	TUBO RIGIDO	TUYAU RIGIDE	ROHR	PIPE	TUBO RIGIDO

PM 21 - PM 23 P

matr. G107.0005

TAV. GL.02.01

POS.	N° CODICE	Q.	DESCRIZIONE	DESIGNATION	BENENNUNG	DESCRIPTION	DENOMINACIONES
1	409586	4	RACCORDO	RACCORD	ANSCHLUSS	FITTING	RACOR
2	495541	1	VALVOLA	SOUPAPE	VENTIL	VALVE	VALVULA
3	417025	3	RONDELLA	RONDELLE	SCHEIBE	WASHER	ARANDELA
4	497966	2	VITE	VIS	SCHRAUBE	SCREW	TORNILLO
5	460080	1	TUBO RIGIDO	TUYAU RIGIDE	ROHR	PIPE	TUBO RIGIDO
6	460081	1	TUBO RIGIDO	TUYAU RIGIDE	ROHR	PIPE	TUBO RIGIDO
7	467478	1	SUPPORTO	SUPPORT	TRÄGER	SUPPORT	SOPORTE
8	373926	2	PATTINO	PATIN	GLEITBLOCK	SLIDING BLOCK	PATIN
9	497238	6	VITE	VIS	SCHRAUBE	SCREW	TORNILLO
10	417004	12	RONDELLA	RONDELLE	SCHEIBE	WASHER	ARANDELA
11	497029	6	VITE	VIS	SCHRAUBE	SCREW	TORNILLO
12	191168	6	DADO	ECROU	MUTTER	NUT	TUERCA
13	467485	4	SUPPORTO	SUPPORT	TRÄGER	SUPPORT	SOPORTE
14	497383	8	VITE	VIS	SCHRAUBE	SCREW	TORNILLO
15	262170	1	SPESSORE	EPAISSEUR	DICKE	THICKNESS	ESPEJOR
16	353099	1	MORSETTO	ETAU	KLEMME	CLAMP	PRENSOR
17	497251	1	VITE	VIS	SCHRAUBE	SCREW	TORNILLO
18	308991	2	SPESSORE	EPAISSEUR	DICKE	THICKNESS	ESPEJOR
19	460083	1	TUBO RIGIDO	TUYAU RIGIDE	ROHR	PIPE	TUBO RIGIDO
20	460082	1	TUBO RIGIDO	TUYAU RIGIDE	ROHR	PIPE	TUBO RIGIDO
21	467479	1	SUPPORTO	SUPPORT	TRÄGER	SUPPORT	SOPORTE
22	410386	2	RACCORDO	RACCORD	ANSCHLUSS	FITTING	RACOR
23	308611	2	SPESSORE	EPAISSEUR	DICKE	THICKNESS	ESPEJOR
24	380407	1	PERNO	AXE	BOLZEN	PIN	PERNO
25	455221	4	SPINA	GOUPILLE	STIFT	PIN	PASADOR
26	380461	1	PERNO	AXE	BOLZEN	PIN	PERNO



COMPL. COMANDO MARTINETTO SFILLO 3° BRACCIO IDRAULICO

* Compl. commande vérin extension 3ème bras hydrauliques
* Hydr. 3. Arm Ausziehzylindersteuerung - Ergänzung
* Hydraulic 3rd arm extension cylinder control compl.
* Complet. mando cilindro extensión 3º brazo hidráulico

TAV. GL.03.01

matr. G107.0005

21
23 P

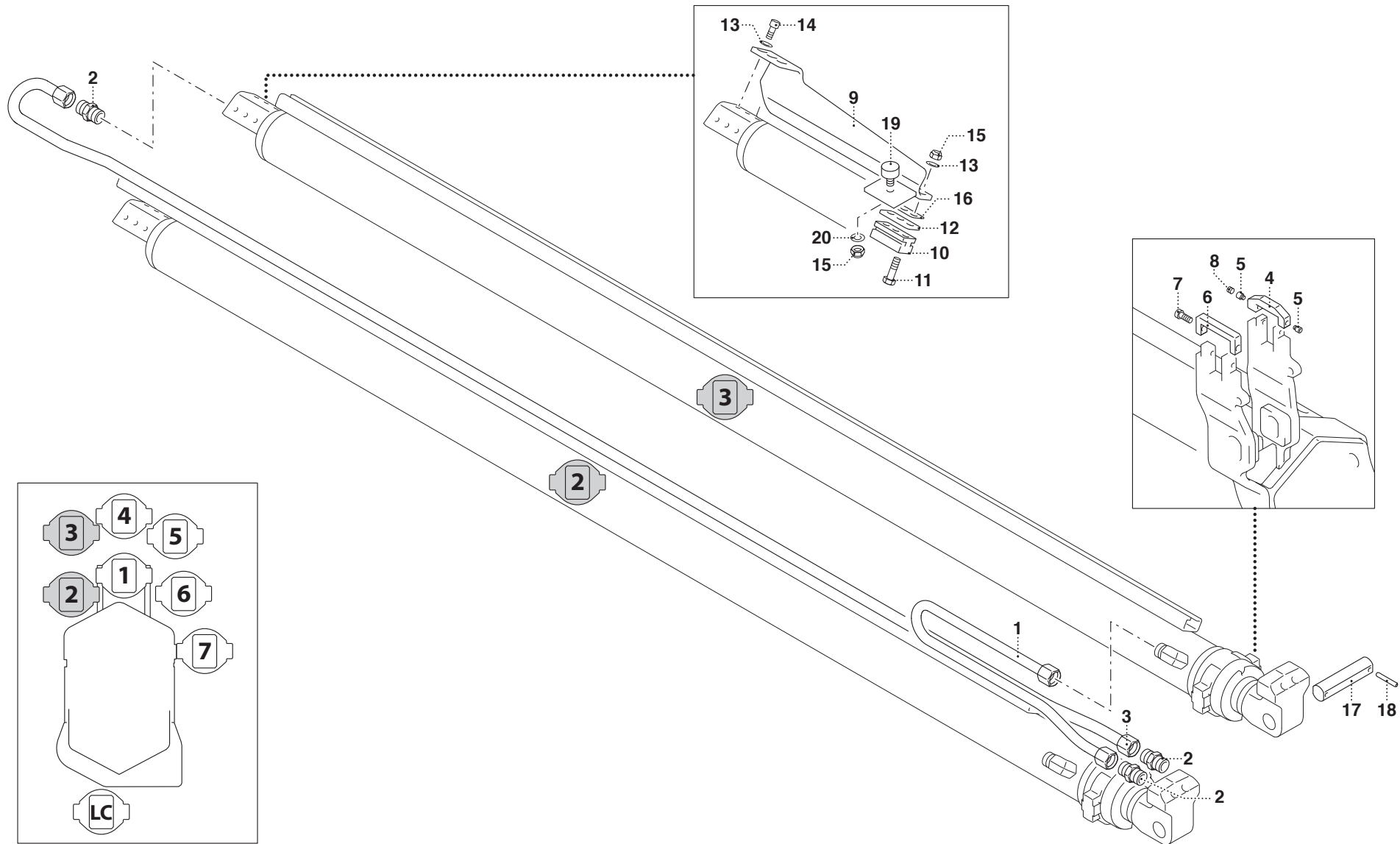

PM 21 - PM 23 P

matr. G107.0005

TAV. GL.03.01

POS.	N° CODICE	Q.	DESCRIZIONE	DESIGNATION	BENENNUNG	DESCRIPTION	DENOMINACIONES
1	460084	1	TUBO RIGIDO	TUYAU RIGIDE	ROHR	PIPE	TUBO RIGIDO
2	410386	3	RACCORDO	RACCORD	ANSCHLUSS	FITTING	RACOR
3	460085	1	TUBO RIGIDO	TUYAU RIGIDE	ROHR	PIPE	TUBO RIGIDO
4	467487	1	FERMO	ARRET	VERSTELLVORRICHTUNG	LOCK	TOPE
5	497295	2	VITE	VIS	SCHRAUBE	SCREW	TORNILLO
6	467485	1	FERMO	ARRET	VERSTELLVORRICHTUNG	LOCK	TOPE
7	497383	2	VITE	VIS	SCHRAUBE	SCREW	TORNILLO
8	497293	1	VITE	VIS	SCHRAUBE	SCREW	TORNILLO
9	467480	1	SUPPORTO	SUPPORT	TRÄGER	SUPPORT	SOPORTE
10	373926	1	PATTINO	PATIN	GLEITBLOCK	SLIDING BLOCK	PATIN
11	497029	3	VITE	VIS	SCHRAUBE	SCREW	TORNILLO
12	308991	1	SPESSORE	EPAISSEUR	DICKE	THICKNESS	ESPEJOR
13	417004	6	RONDELLA	RONDELLE	SCHEIBE	WASHER	ARANDELA
14	497238	3	VITE	VIS	SCHRAUBE	SCREW	TORNILLO
15	191168	4	DADO	ECROU	MUTTER	NUT	TUERCA
16	308611	1	SPESSORE	EPAISSEUR	DICKE	THICKNESS	ESPEJOR
17	380407	1	PERNO	AXE	BOLZEN	PIN	PERNO
18	455221	2	SPINA	GOUPILLE	STIFT	PIN	PASADOR
19	118025	1	ANTIVIBRANTE	PLOT ELASTIQUE	SCHWINGUNGSDAMPFER	PAD	ANTIVIBRANTE
20	417025	1	RONDELLA	RONDELLE	SCHEIBE	WASHER	ARANDELA



COMPL. COMANDO MARTINETTO SFILLO 4° BRACCIO IDRAULICO

* Compl. commande vérin extension 4^{ème} bras hydrauliques
* Hydr. 4. Arm Ausziehzylindersteuerung - Ergänzung
* Hydraulic 4th arm extension cylinder control compl.
* Complet. mando cilindro extensión 4° brazo hidráulico

TAV. GL.04.01

matr. G107.0005

21
23 P

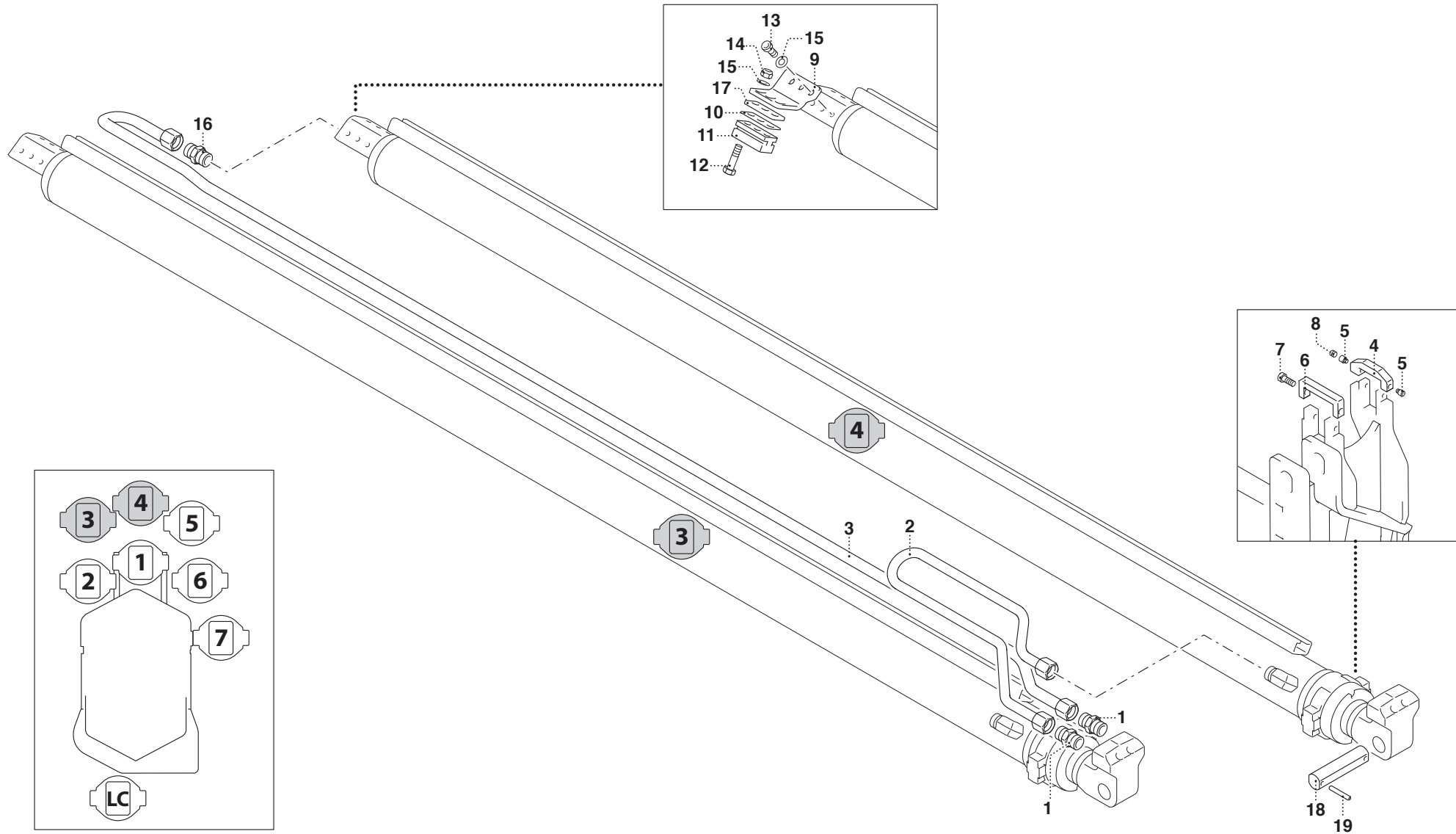

PM 21 - PM 23 P

matr. G107.0005

TAV. GL.04.01

POS.	N° CODICE	Q.	DESCRIZIONE	DESIGNATION	BENENNUNG	DESCRIPTION	DENOMINACIONES
1	409586	2	RACCORDO	RACCORD	ANSCHLUSS	FITTING	RACOR
2	460086	1	TUBO RIGIDO	TUYAU RIGIDE	ROHR	PIPE	TUBO RIGIDO
3	460087	1	TUBO RIGIDO	TUYAU RIGIDE	ROHR	PIPE	TUBO RIGIDO
4	467487	1	FERMO	ARRET	VERSTELLVORRICHTUNG	LOCK	TOPE
5	497295	2	VITE	VIS	SCHRAUBE	SCREW	TORNILLO
6	467485	1	FERMO	ARRET	VERSTELLVORRICHTUNG	LOCK	TOPE
7	497383	2	VITE	VIS	SCHRAUBE	SCREW	TORNILLO
8	497293	1	VITE	VIS	SCHRAUBE	SCREW	TORNILLO
9	467481	1	SUPPORTO	SUPPORT	TRÄGER	SUPPORT	SOPORTE
10	308991	1	SPESSORE	EPAISSEUR	DICKE	THICKNESS	ESPEJOR
11	373926	1	PATTINO	PATIN	GLEITBLOCK	SLIDING BLOCK	PATIN
12	497029	3	VITE	VIS	SCHRAUBE	SCREW	TORNILLO
13	497238	3	VITE	VIS	SCHRAUBE	SCREW	TORNILLO
14	191168	3	DADO	ECROU	MUTTER	NUT	TUERCA
15	417004	6	RONDELLA	RONDELLE	SCHEIBE	WASHER	ARANDELA
16	410386	1	RACCORDO	RACCORD	ANSCHLUSS	FITTING	RACOR
17	308611	1	SPESSORE	EPAISSEUR	DICKE	THICKNESS	ESPEJOR
18	380407	1	PERNO	AXE	BOLZEN	PIN	PERNO
19	455221	2	SPINA	GOUPILLE	STIFT	PIN	PASADOR



COMPL. COMANDO MARTINETTO SFILO 5° BRACCIO IDRAULICO

- * Compl. commande vérin extension 5ème bras hydrauliques
- * Hydr. 5. Arm Ausziehzylindersteuerung - Ergänzung
- * Hydraulic 5th arm extension cylinder control compl.
- * Complet. mando cilindro extensión 5° brazo hidráulico

TAV. GL.05.01

matr. G107.0005

21
23 P

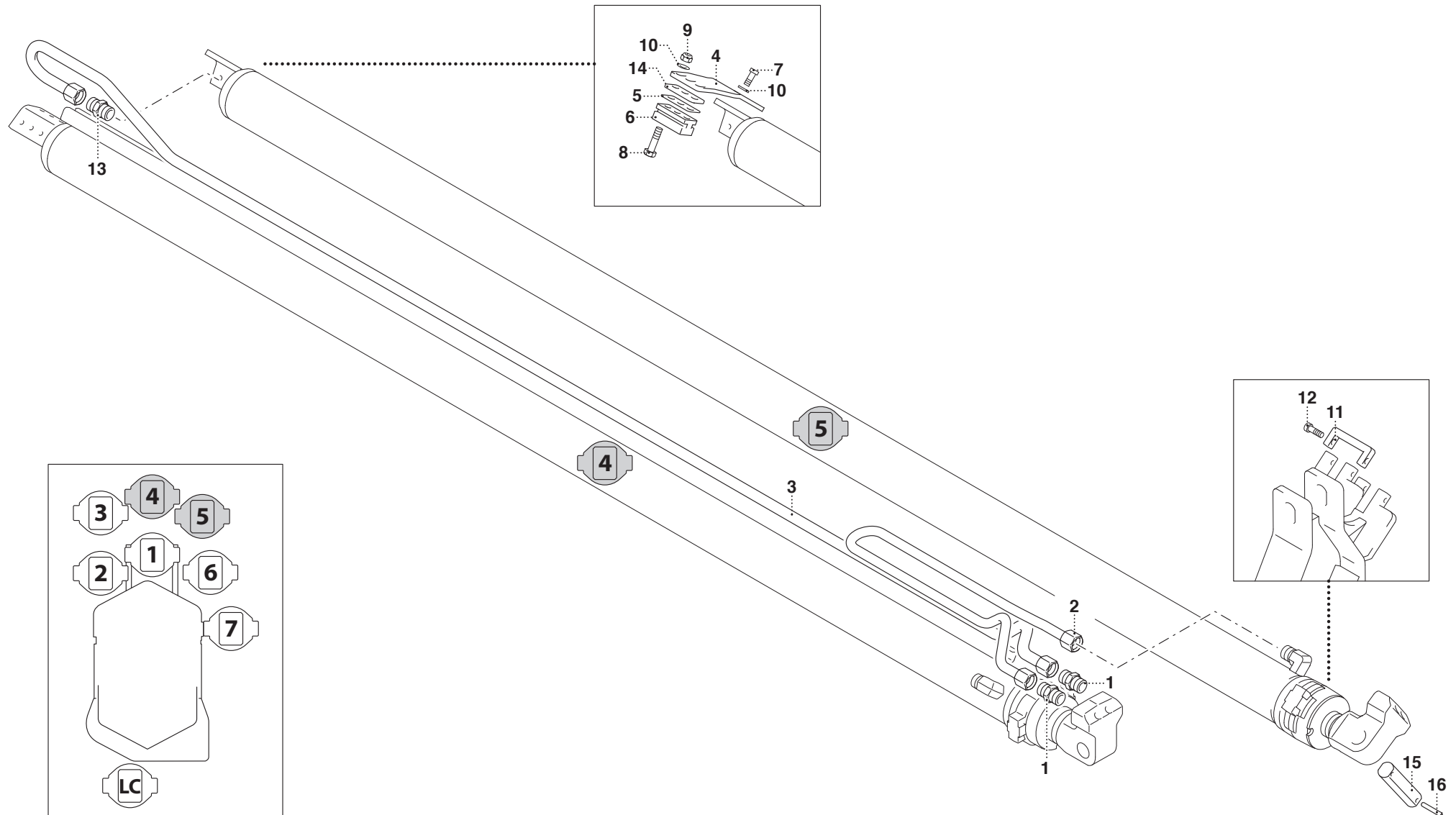

PM 21 - PM 23 P**matr. G107.0005****TAV. GL.05.01**

POS.	N° CODICE	Q.	DESCRIZIONE	DESIGNATION	BENENNUNG	DESCRIPTION	DENOMINACIONES
1	409586	2	RACCORDO	RACCORD	ANSCHLUSS	FITTING	RACOR
2	460088	1	TUBO RIGIDO	TUYAU RIGIDE	ROHR	PIPE	TUBO RIGIDO
3	460089	1	TUBO RIGIDO	TUYAU RIGIDE	ROHR	PIPE	TUBO RIGIDO
4	467482	1	SUPPORTO	SUPPORT	TRÄGER	SUPPORT	SOPORTE
5	308991	1	SPESSORE	EPAISSEUR	DICKE	THICKNESS	ESPEJOR
6	373926	1	PATTINO	PATIN	GLEITBLOCK	SLIDING BLOCK	PATIN
7	497238	3	VITE	VIS	SCHRAUBE	SCREW	TORNILLO
8	497029	3	VITE	VIS	SCHRAUBE	SCREW	TORNILLO
9	191168	3	DADO	ECROU	MUTTER	NUT	TUERCA
10	417004	6	RONDELLA	RONDELLE	SCHEIBE	WASHER	ARANDELA
11	467485	2	FERMO	ARRET	VERSTELLVORRICHTUNG	LOCK	TOPE
12	497383	4	VITE	VIS	SCHRAUBE	SCREW	TORNILLO
13	410386	1	RACCORDO	RACCORD	ANSCHLUSS	FITTING	RACOR
14	308611	1	SPESSORE	EPAISSEUR	DICKE	THICKNESS	ESPEJOR
15	380407	1	PERNO	AXE	BOLZEN	PIN	PERNO
16	455221	2	SPINA	GOUPILLE	STIFT	PIN	PASADOR



COMPL. COMANDO MARTINETTO SFILLO 6° BRACCIO IDRAULICO

* Compl. commande vérin extension 6ème bras hydrauliques
* Hydr. 6 Arm Ausziehzyylindersteuerung - Ergänzung
* Hydraulic 6th arm extension cylinder control compl.
* Complet. mando cilindro extensión 6° brazo hidráulico

TAV. GL.06.01

matr. G107.0005

21
23 P

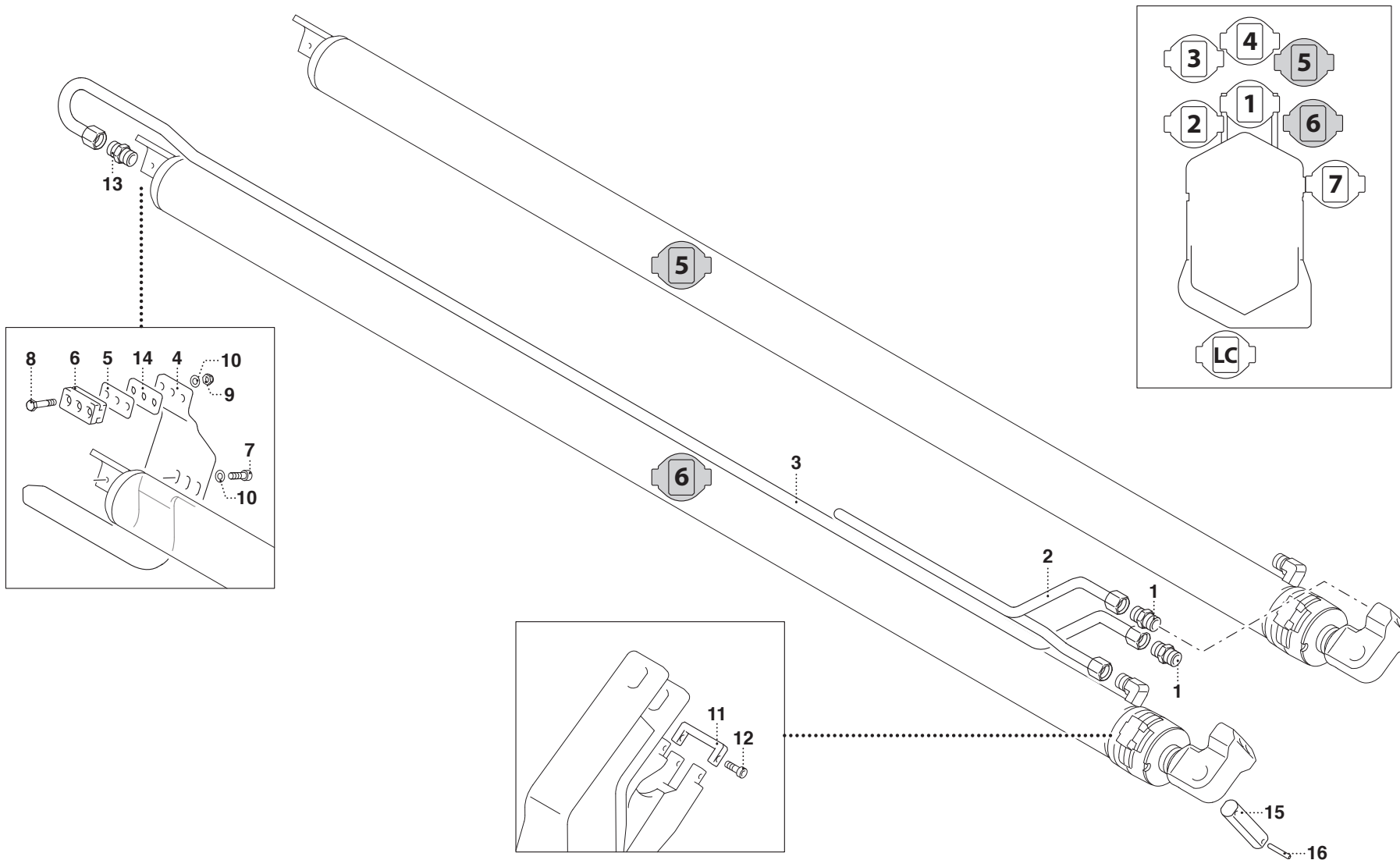

PM 21 - PM 23 P**matr. G107.0005****TAV. GL.06.01**

POS.	N° CODICE	Q.	DESCRIZIONE	DESIGNATION	BENENNUNG	DESCRIPTION	DENOMINACIONES
1	409586	2	RACCORDO	RACCORD	ANSCHLUSS	FITTING	RACOR
2	460090	1	TUBO RIGIDO	TUYAU RIGIDE	ROHR	PIPE	TUBO RIGIDO
3	460091	1	TUBO RIGIDO	TUYAU RIGIDE	ROHR	PIPE	TUBO RIGIDO
4	467483	1	SUPPORTO	SUPPORT	TRÄGER	SUPPORT	SOPORTE
5	308991	1	SPESSORE	EPAISSEUR	DICKE	THICKNESS	ESPEJOR
6	373926	1	PATTINO	PATIN	GLEITBLOCK	SLIDING BLOCK	PATIN
7	497238	3	VITE	VIS	SCHRAUBE	SCREW	TORNILLO
8	497029	3	VITE	VIS	SCHRAUBE	SCREW	TORNILLO
9	191168	3	DADO	ECROU	MUTTER	NUT	TUERCA
10	417004	6	RONDELLA	RONDELLE	SCHEIBE	WASHER	ARANDELA
11	467485	2	FERMO	ARRET	VERSTELLVORRICHTUNG	LOCK	TOPE
12	497383	4	VITE	VIS	SCHRAUBE	SCREW	TORNILLO
13	410386	1	RACCORDO	RACCORD	ANSCHLUSS	FITTING	RACOR
14	308611	1	SPESSORE	EPAISSEUR	DICKE	THICKNESS	ESPEJOR
15	380407	1	PERNO	AXE	BOLZEN	PIN	PERNO
16	455221	2	SPINA	GOUPILLE	STIFT	PIN	PASADOR



COMPL. COMANDO MARTINETTO SFILLO 7° BRACCIO IDRAULICO

* Compl. commande vérin extension 7ème bras hydrauliques
* Hydr. 7 Arm Ausziehzyylindersteuerung - Ergänzung
* Hydraulic 7th arm extension cylinder control compl.
* Complet. mando cilindro extensión 7° brazo hidráulico

TAV. GL.07.01

matr. G107.0005

21
23 P

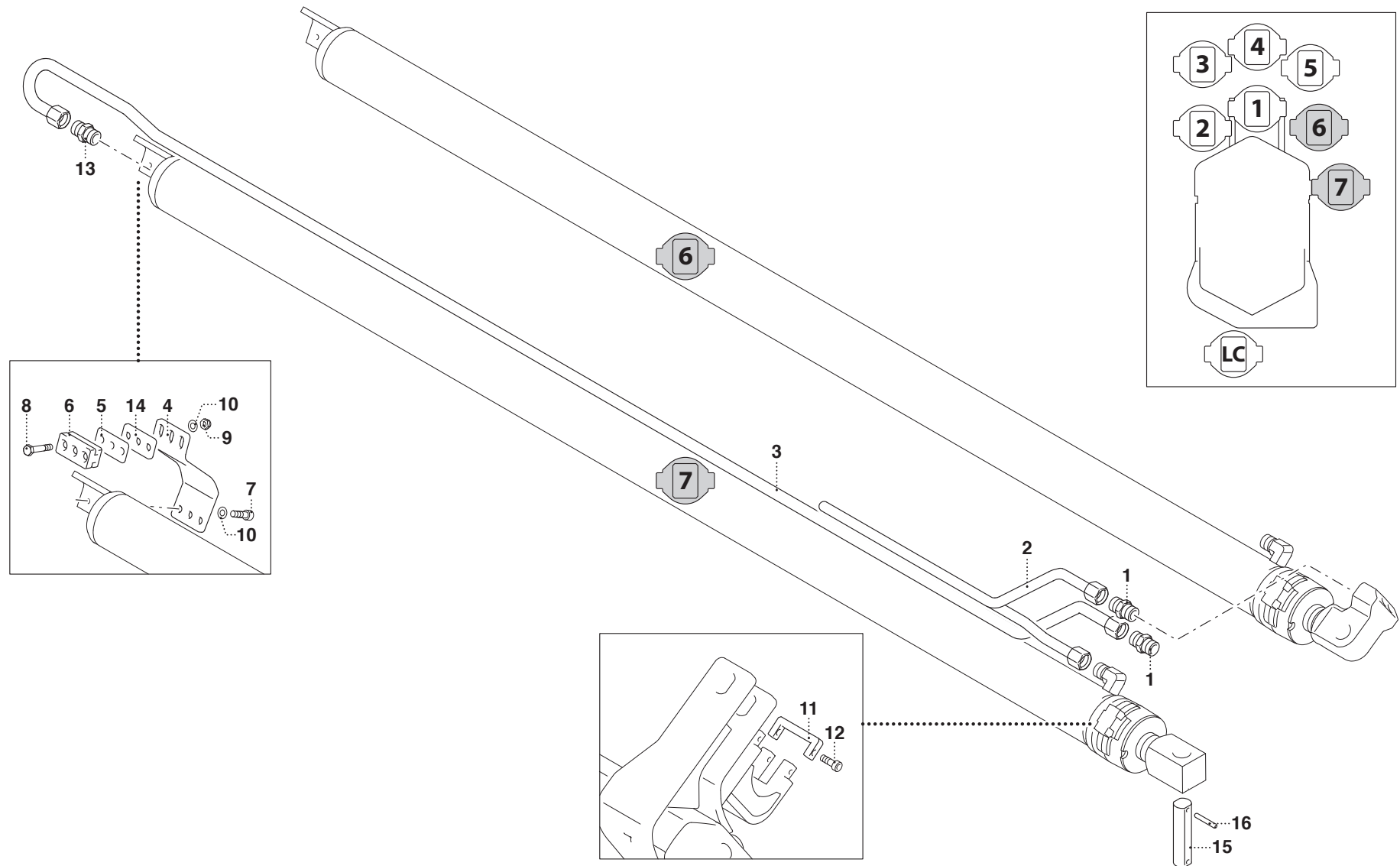

PM 21 - PM 23 P

matr. G107.0005

TAV. GL.07.01

POS.	N° CODICE	Q.	DESCRIZIONE	DESIGNATION	BENENNUNG	DESCRIPTION	DENOMINACIONES
1	409586	2	RACCORDO	RACCORD	ANSCHLUSS	FITTING	RACOR
2	460092	1	TUBO RIGIDO	TUYAU RIGIDE	ROHR	PIPE	TUBO RIGIDO
3	460093	1	TUBO RIGIDO	TUYAU RIGIDE	ROHR	PIPE	TUBO RIGIDO
4	467484	1	SUPPORTO	SUPPORT	TRÄGER	SUPPORT	SOPORTE
5	308991	1	SPESSORE	EPAISSEUR	DICKE	THICKNESS	ESPEJOR
6	373926	1	PATTINO	PATIN	GLEITBLOCK	SLIDING BLOCK	PATIN
7	497238	3	VITE	VIS	SCHRAUBE	SCREW	TORNILLO
8	497029	3	VITE	VIS	SCHRAUBE	SCREW	TORNILLO
9	191168	3	DADO	ECROU	MUTTER	NUT	TUERCA
10	417004	6	RONDELLA	RONDELLE	SCHEIBE	WASHER	ARANDELA
11	467485	2	FERMO	ARRET	VERSTELLVORRICHTUNG	LOCK	TOPE
12	497383	4	VITE	VIS	SCHRAUBE	SCREW	TORNILLO
13	410386	1	RACCORDO	RACCORD	ANSCHLUSS	FITTING	RACOR
14	308611	1	SPESSORE	EPAISSEUR	DICKE	THICKNESS	ESPEJOR
15	380407	1	PERNO	AXE	BOLZEN	PIN	PERNO
16	455221	2	SPINA	GOUPILLE	STIFT	PIN	PASADOR



LUBRIFICAZIONE CENTRALIZZATA

- * Graissage centralisé
- * Sammelschmierung
- * Centralised lubrication
- * Lubricación centralizada

TAV. GM.01.01

matr. G107.0005

21
23 P

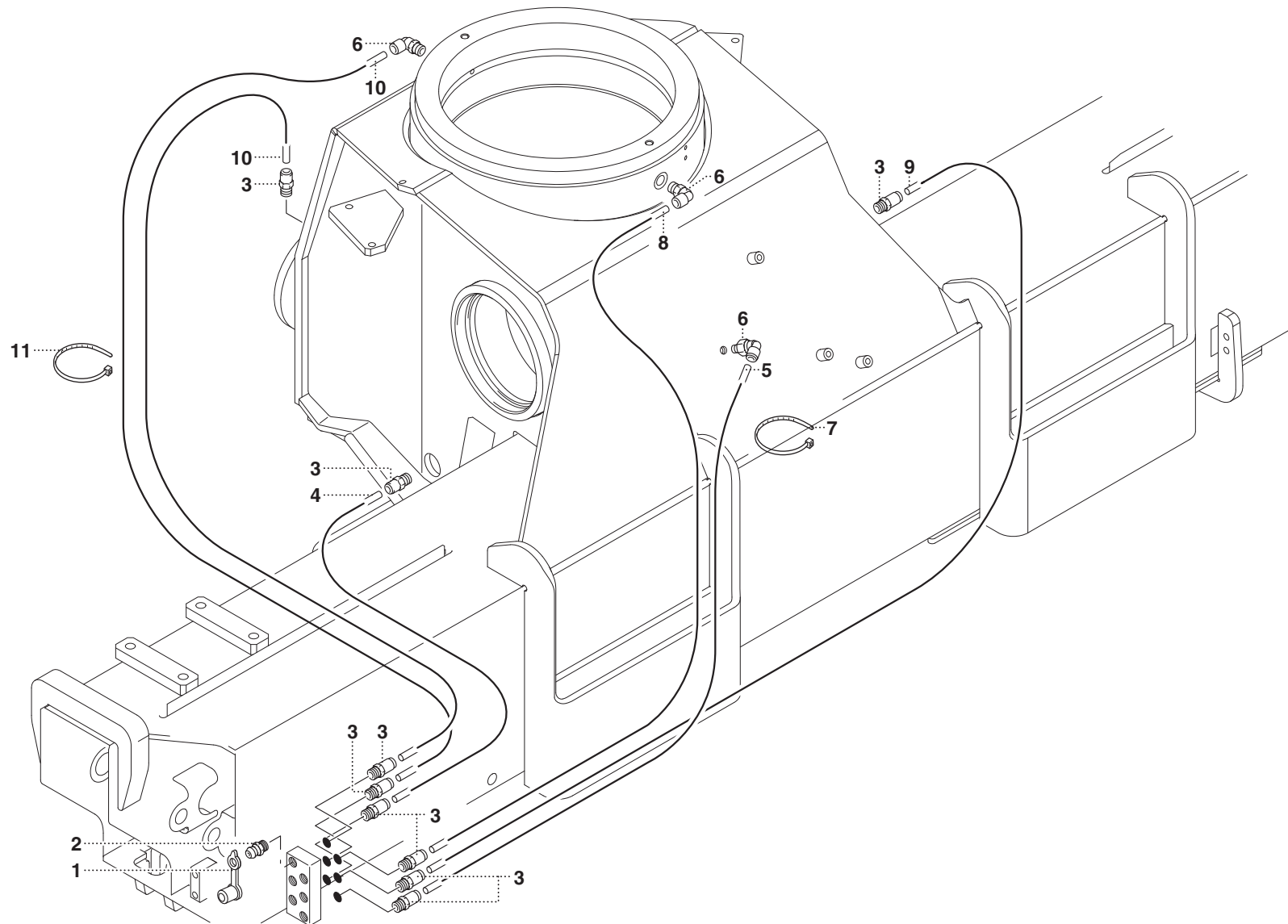



DISTRIBUTORE DANFOSS 5 ELEMENTI - H -197673 (21)

- * Distributeur DANFOSS - 5 éléments - H
- * DANFOSS-Steuerventilblock - 5 Elemente - H
- * DANFOSS control valve block - 5 elements - H
- * Distribuidor DANFOSS 5 elementos - H

TAV. GN.01.01

matr. G107.0005

21
23 P

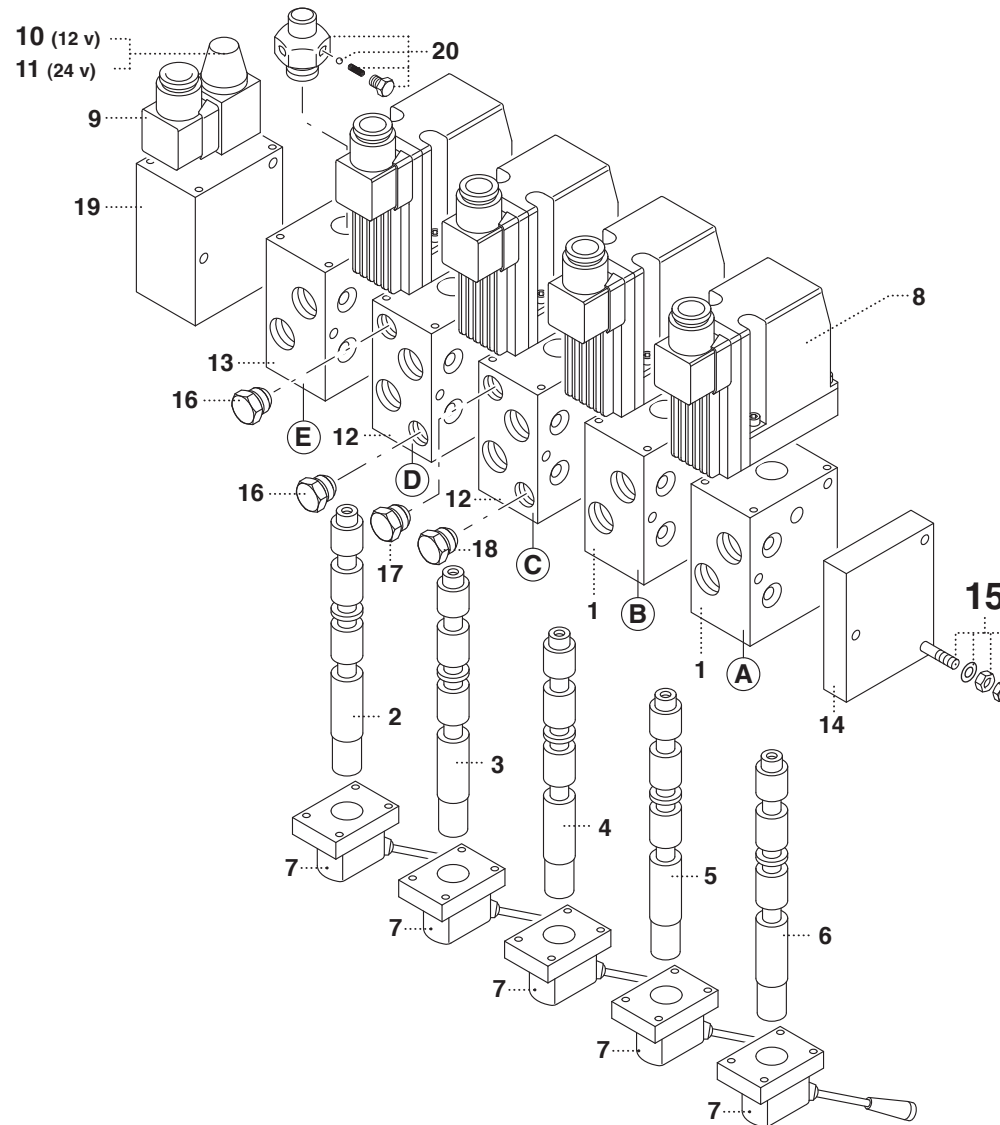

PM 21

matr. G107.0005

TAV. GN.01.01

POS.	N° CODICE	Q.	DESCRIZIONE	DESIGNATION	BENENNUNG	DESCRIPTION	DENOMINACIONES
1	202135	2	CORPO	CORPS	GEHÄUSE	BODY	CUERPO
2	202114	1	ASTA STABILIZZATORE	TIGE STABILISATEUR	STABILISATORSTANGE	STABILISATOR ROD	VARILLA ESTABILIZADOR
3	202280	1	ASTA ROTAZIONE	TIGE ROTATION	DREHSTANGE	ROTATION ROD	VARILLA ROTACION
4	202252	1	ASTA COLONNA	TIGE COLONNE	SÄULESTANGE	COLUMN ROD	VARILLA COLUMNA
5	202221	1	ASTA BRACCIO PRINCIPALE	TIGE BRAS PRINCIPAL	HAUPTARMSTANGE	MAIN ARM ROD	VARILLA BRAZO PRINC.
6	202149	1	ASTA SFILO BRACCI	TIGE EXTENSION BRAS	ARMAUSZIEHENSTANGE	ROD - ARM EXTENSION	VARILLA EXTEN.BRAZOS
7	202123	5	ORGANO DI MANOVRA	DISPOSITIF MOUVEMENT	SCHALTVORRICHTUNG	MOTION DEVICE	ORGANO DE MANOVRA
8	202219	4	MODULO	MODULE	MODULE	MODUL	MODULO
9	204055	1	ELETTROVALVOLA	ELECTROVANNE	ELEKTROVENTIL	ELECTROVALVE	ELECTRO-VALVULA
10	395379	1	BOBINA	BOBINE	SPULE	COIL	BOBINA
11	395380	1	BOBINA	BOBINE	SPULE	COIL	BOBINA
12	202158	2	CORPO	CORPS	GEHÄUSE	BODY	CUERPO
13	202156	1	CORPO	CORPS	GEHÄUSE	BODY	CUERPO
14	202233	1	FIANCATA	COTE	SEITENWAND	SIDE PANEL	LADO
15	202162	1	KIT TIRANTE	KIT TIRANT	ZUGSTANGESATZ	TIE ROD KIT	KIT TIRANTE
16	202105	2	VALVOLA	SOUPAPE	VENTIL	VALVE	VALVULA
17	202255	1	VALVOLA	SOUPAPE	VENTIL	VALVE	VALVULA
18	202274	1	VALVOLA	SOUPAPE	VENTIL	VALVE	VALVULA
19	202179	1	FIANCATA	COTE	SEITENWAND	SIDE PANEL	LADO
20	202125	1	DISPOSITIVO DI FERMO	DISPOSITIF D'ARRET	FESTELLVORRICHTUNG	RETAINER DEVICE	DISPOSITIVO DE TOPE
A	202366	1	ELEMENTO SFILO BRACCI	ELEMENT EXTENS. BRAS	ARMAUSZIEHENELEMENT	ARM EXTENSION ELEMENT	ELEMENT EXT. BRAZOS
B	202365	1	ELEMENTO BRACCIO PRINCIPALE	ELEMENT BRAS PRINCIPAL	HAUPTARMELEMENT	MAIN ARM ELEMENT	ELEM. BRAZO PRINC.
C	364364	1	ELEMENTO COLONNA	ELEMENT COLONNE	SÄULEELEMENT	COLUMN ELEMENT	ELEMENTO COLUMNA
D	202363	1	ELEMENTO ROTAZIONE	ELEMENT ROTATION	DREHUNGELEMENT	ROTATION ELEMENT	ELEMENTO ROTACION
E	202143	1	ELEMENTO STABILIZZATORE	ELEMENT STABILISATEUR	STABILISATORELEMENT	STABILISATOR ELEMENT	ELEM. ESTABILIZADOR

PM 21

matr. G107.0005

TAV. GN.01.02

POS.	N° CODICE	Q.	DESCRIZIONE	DESIGNATION	BENENNUNG	DESCRIPTION	DENOMINACIONES
1	202135	3	CORPO	CORPS	GEHÄUSE	BODY	CUERPO
2	202114	1	ASTA STABILIZZATORE	TIGE STABILISATEUR	STABILISATORSTANGE	STABILISATOR ROD	VARILLA ESTABILIZADOR
3	202280	1	ASTA ROTAZIONE	TIGE ROTATION	DREHSTANGE	ROTATION ROD	VARILLA ROTACION
4	202252	1	ASTA COLONNA	TIGE COLONNE	SÄULESTANGE	COLUMN ROD	VARILLA COLUMNA
5	202221	1	ASTA BRACCIO PRINCIPALE	TIGE BRAS PRINCIPAL	HAUPTARMSTANGE	MAIN ARM ROD	VARILLA BRAZO PRINC.
6	202149	1	ASTA SFILO BRACCI	TIGE EXTENSION BRAS	ARMAUSZIEHENSTANGE	ROD - ARM EXTENSION	VARILLA EXTEN.BRAZOS
7	202123	6	ORGANO DI MANOVRA	DISPOSITIF MOUVEMENT	SCHALTVORRICHTUNG	MOTION DEVICE	ORGANO DE MANOVRA
8	202219	5	MODULO	MODULE	MODULE	MODUL	MODULO
9	204055	1	ELETTROVALVOLA	ELECTROVANNE	ELEKTROVENTIL	ELECTROVALVE	ELECTRO-VALVULA
10	395379	1	BOBINA	BOBINE	SPULE	COIL	BOBINA
11	395380	1	BOBINA	BOBINE	SPULE	COIL	BOBINA
12	202105	2	VALVOLA	SOUPAPE	VENTIL	VALVE	VALVULA
13	202156	1	CORPO	CORPS	GEHÄUSE	BODY	CUERPO
14	202251	1	ASTA 1° ATTIVAZIONE	TIGE - 1ERE ACTIVATION	STANGE - 1.BETÄTIGUNG	ROD - 1ST ACTIVATION	VARILLA-1ERA ACTIVAC.
15	202125	1	DISPOSITIVO DI FERMO	DISPOSITIF D'ARRET	FESTELLVORRICHTUNG	RETAINER DEVICE	DISPOSITIVO DE TOPE
16	202158	2	CORPO	CORPS	GEHÄUSE	BODY	CUERPO
17	202138	1	KIT TIRANTE	KIT TIRANT	ZUGSTANGESATZ	TIE ROD KIT	KIT TIRANTE
18	202255	1	VALVOLA	SOUPAPE	VENTIL	VALVE	VALVULA
19	202274	1	VALVOLA	SOUPAPE	VENTIL	VALVE	VALVULA
20	202179	1	FIANCATA	COTE	SEITENWAND	SIDE PANEL	LADO
21	202233	1	FIANCATA	COTE	SEITENWAND	SIDE PANEL	LADO
A	202348	1	ELEMENTO 1° ATTIVAZIONE	ELEMENT 1E ACTIVATION	1.BETÄTIGUNSELEMENT	1ST ACTIVAT. ELEMENT	ELEMENTO 1A ACTIVAC.
B	202366	1	ELEMENTO SFILO BRACCI	ELEMENT EXTENS. BRAS	ARMAUSZIEHENELEMENT	ARM EXTENSION ELEMENT	ELEMENT EXT. BRAZOS
C	202365	1	ELEMENTO BRACCIO PRINCIPALE	ELEMENT BRAS PRINCIPAL	HAUPTARMELEMENT	MAIN ARM ELEMENT	ELEM. BRAZO PRINC.
D	202364	1	ELEMENTO COLONNA	ELEMENT COLONNE	SÄULEELEMENT	COLUMN ELEMENT	ELEMENTO COLUMNA
E	202363	1	ELEMENTO ROTAZIONE	ELEMENT ROTATION	DREHUNGELEMENT	ROTATION ELEMENT	ELEMENTO ROTACION



DISTRIBUTORE DANFOSS 6 ELEMENTI - H - 1° ATTIVAZIONE - 197675 (21)

* Distributeur DANFOSS - 6 éléments - H 1ère activation
* DANFOSS-Steuerventilblock - 6 Elemente - H - 1. Betätigung
* DANFOSS control valve block - 6 elements - H - 1st activation
* Distribuidor DANFOSS 6 elementos - H - 1era activación

TAV. GN.01.02

matr. G107.0005

21
23 P

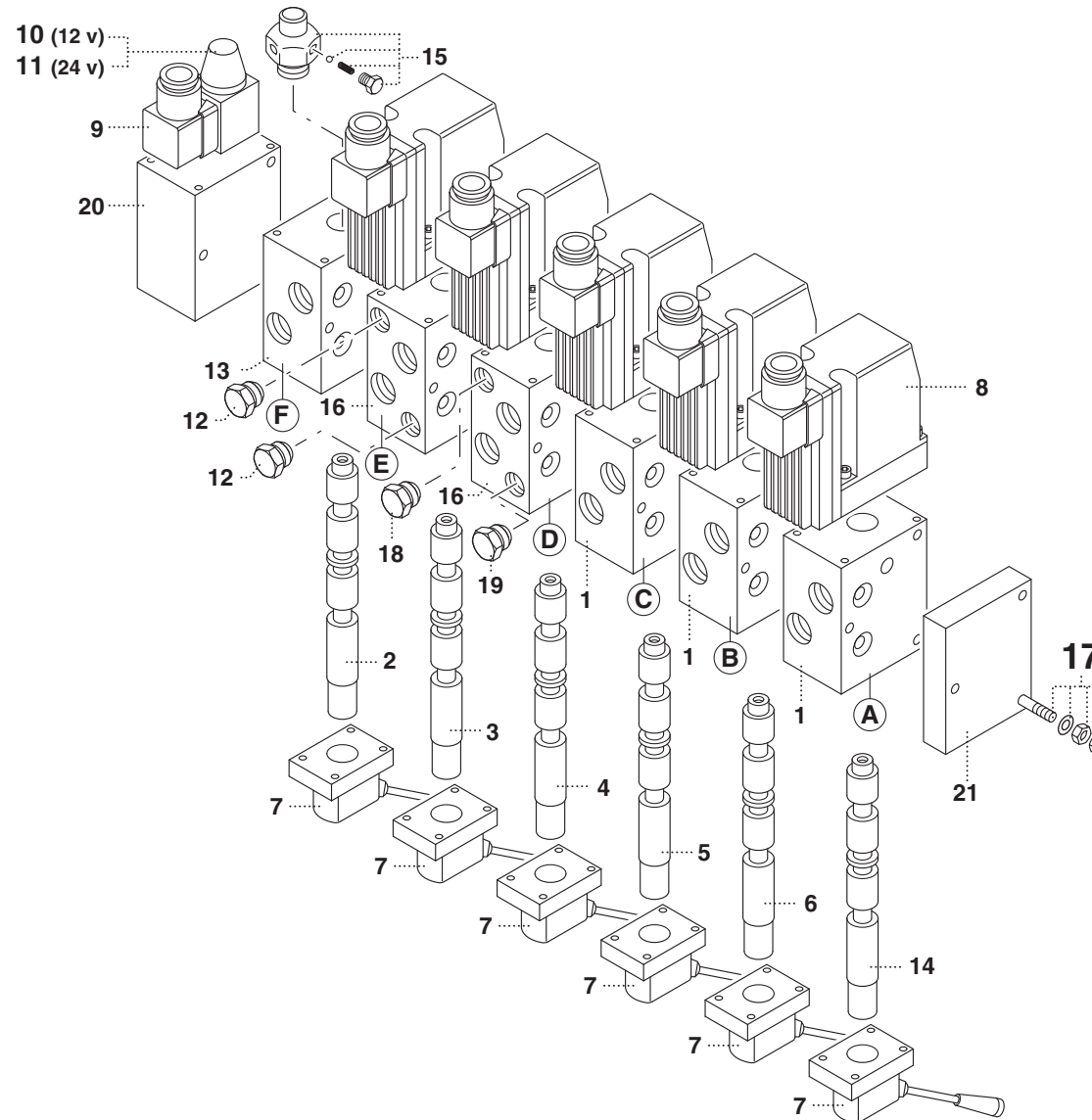



DISTRIBUTORE DANFOSS 6 ELEMENTI - H - ARGANO - 197674 (21)

* Distributeur DANFOSS - 6 éléments - H - treuil
* DANFOSS-Steuerventilblock - 6 Elemente - H - Winde
* DANFOSS control valve block - 6 elements - H - winch
* Distribuidor DANFOSS 6 elementos - H - cabrestante

TAV. GN.01.03

matr. G107.0005

21
23 P

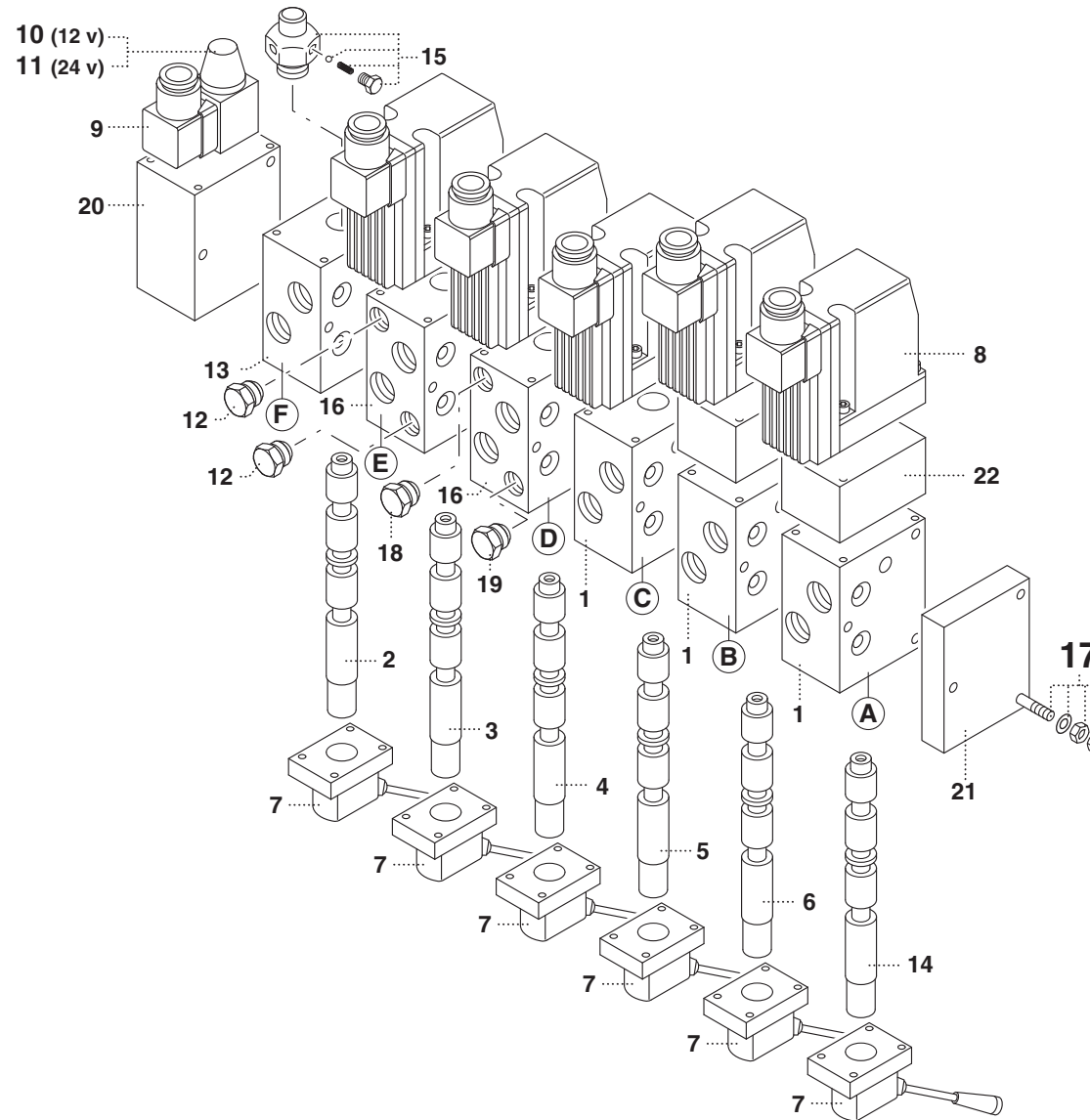

PM 21

matr. G107.0005

TAV. GN.01.03

POS.	N° CODICE	Q.	DESCRIZIONE	DESIGNATION	BENENNUNG	DESCRIPTION	DENOMINACIONES
1	202135	3	CORPO	CORPS	GEHÄUSE	BODY	CUERPO
2	202114	1	ASTA STABILIZZATORE	TIGE STABILISATEUR	STABILISATORSTANGE	STABILISATOR ROD	VARILLA ESTABILIZADOR
3	202280	1	ASTA ROTAZIONE	TIGE ROTATION	DREHSTANGE	ROTATION ROD	VARILLA ROTACION
4	202252	1	ASTA COLONNA	TIGE COLONNE	SÄULESTANGE	COLUMN ROD	VARILLA COLUMNA
5	202221	1	ASTA BRACCIO PRINCIPALE	TIGE BRAS PRINCIPAL	HAUPTARMSTANGE	MAIN ARM ROD	VARILLA BRAZO PRINC.
6	202149	1	ASTA SFILO BRACCI	TIGE EXTENSION BRAS	ARMAUSZIEHENSTANGE	ROD - ARM EXTENSION	VARILLA EXTEN.BRAZOS
7	202123	6	ORGANO DI MANOVRA	DISPOSITIF MOUVEMENT	SCHALTVORRICHTUNG	MOTION DEVICE	ORGANO DE MANOVRA
8	202219	5	MODULO	MODULE	MODULE	MODUL	MODULO
9	204055	1	ELETTROVALVOLA	ELECTROVANNE	ELEKTROVENTIL	ELECTROVALVE	ELECTRO-VALVULA
10	395379	1	BOBINA	BOBINE	SPULE	COIL	BOBINA
11	395380	1	BOBINA	BOBINE	SPULE	COIL	BOBINA
12	202105	2	VALVOLA	SOUPAPE	VENTIL	VALVE	VALVULA
13	202156	1	CORPO	CORPS	GEHÄUSE	BODY	CUERPO
14	202130	1	ASTA ARGANO	TIGE TREUIL	WINDESTANGE	WINCH ROD	VARILLA CABRESANTE
15	202125	1	DISPOSITIVO DI FERMO	DISPOSITIF D'ARRET	FESTELLVORRICHTUNG	RETAINER DEVICE	DISPOSITIVO DE TOPE
16	202158	2	CORPO	CORPS	GEHÄUSE	BODY	CUERPO
17	202138	1	KIT TIRANTE	KIT TIRANT	ZUGSTANGESATZ	TIE ROD KIT	KIT TIRANTE
18	202255	1	VALVOLA	SOUPAPE	VENTIL	VALVE	VALVULA
19	202274	1	VALVOLA	SOUPAPE	VENTIL	VALVE	VALVULA
20	202179	1	FIANCATA	COTE	SEITENWAND	SIDE PANEL	LADO
21	202233	1	FIANCATA	COTE	SEITENWAND	SIDE PANEL	LADO
22	202172	2	MODULO	MODULE	MODULE	MODUL	MODULO
A	202370	1	ELEMENTO ARGANO	ELEMENT TREUIL	WINDEELEMENT	WINCH ELEMENT	ELEM. CABRESTANTE
B	202369	1	ELEMENTO SFILO BRACCI	ELEMENT EXTENS. BRAS	ARMAUSZIEHENELEMENT	ARM EXTENSION ELEMENT	ELEMENT EXT. BRAZOS
C	202365	1	ELEMENTO BRACCIO PRINCIPALE	ELEMENT BRAS PRINCIPAL	HAUPTARMELEMENT	MAIN ARM ELEMENT	ELEM. BRAZO PRINC.
D	202364	1	ELEMENTO COLONNA	ELEMENT COLONNE	SÄULEELEMENT	COLUMN ELEMENT	ELEMENTO COLUMNA



DISTRIBUTORE DANFOSS 6 ELEMENTI - H - ARGANO - 197674 (21)

* Distributeur DANFOSS - 6 éléments - H - treuil
* DANFOSS-Steuerventilblock - 6 Elemente - H - Winde
* DANFOSS control valve block - 6 elements - H - winch
* Distribuidor DANFOSS 6 elementos - H - cabrestante

TAV. GN.01.03

matr. G107.0005

21
23 P

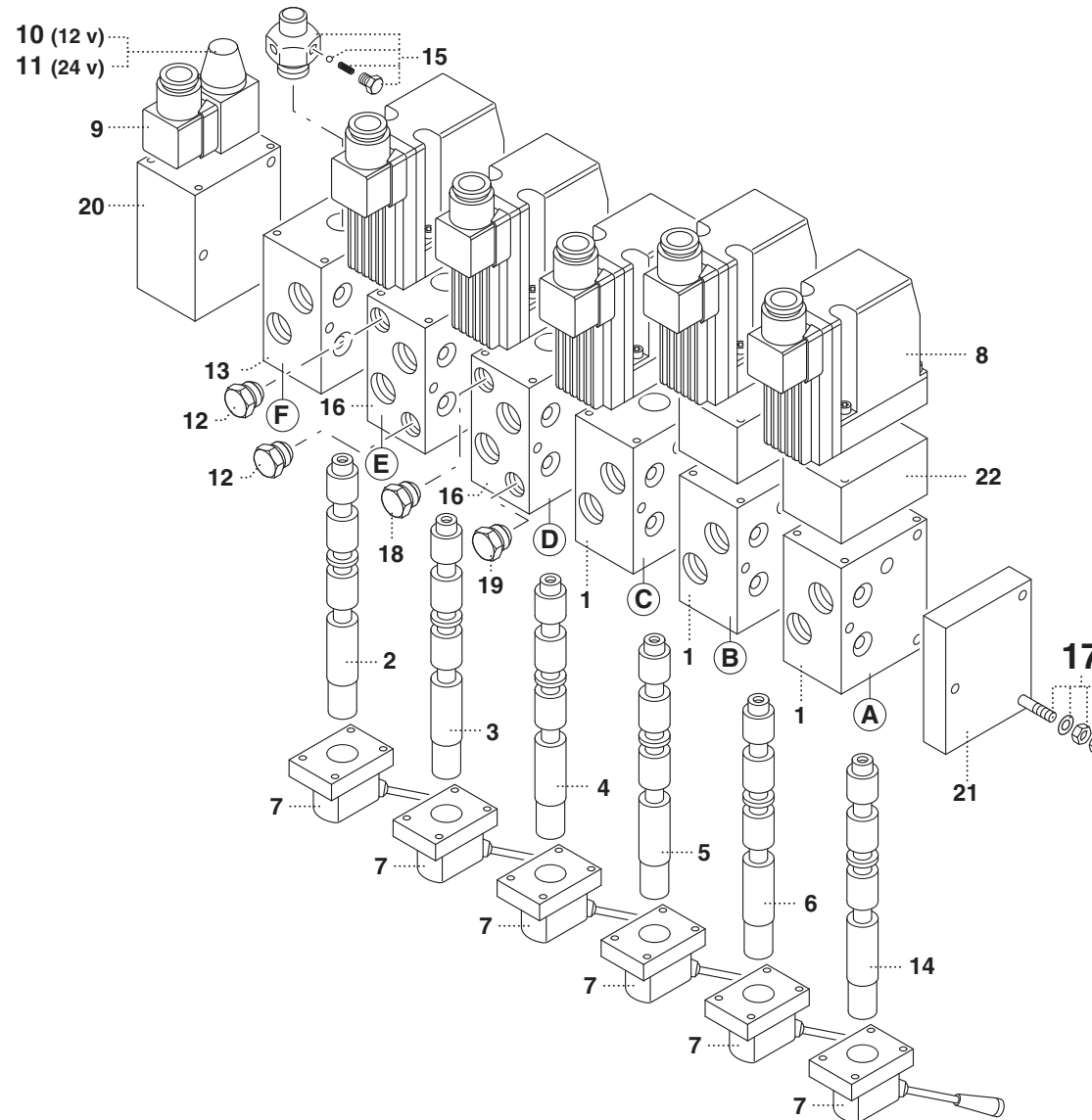

PM 21

matr. G107.0005

TAV. GN.01.04

POS.	N° CODICE	Q.	DESCRIZIONE	DESIGNATION	BENENNUNG	DESCRIPTION	DENOMINACIONES
1	202135	4	CORPO	CORPS	GEHÄUSE	BODY	CUERPO
2	202114	1	ASTA STABILIZZATORE	TIGE STABILISATEUR	STABILISATORSTANGE	STABILISATOR ROD	VARILLA ESTABILIZADOR
3	202280	1	ASTA ROTAZIONE	TIGE ROTATION	DREHSTANGE	ROTATION ROD	VARILLA ROTACION
4	202252	1	ASTA COLONNA	TIGE COLONNE	SÄULESTANGE	COLUMN ROD	VARILLA COLUMNA
5	202221	1	ASTA BRACCIO PRINCIPALE	TIGE BRAS PRINCIPAL	HAUPTARMSTANGE	MAIN ARM ROD	VARILLA BRAZO PRINC.
6	202149	1	ASTA SFILO BRACCI	TIGE EXTENSION BRAS	ARMAUSZIEHENSTANGE	ROD - ARM EXTENSION	VARILLA EXTEN.BRAZOS
7	202123	7	ORGANO DI MANOVRA	DISPOSITIF MOUVEMENT	SCHALTVORRICHTUNG	MOTION DEVICE	ORGANO DE MANOVRA
8	202219	6	MODULO	MODULE	MODULE	MODUL	MODULO
9	204055	1	ELETTROVALVOLA	ELECTROVANNE	ELEKTROVENTIL	ELECTROVALVE	ELECTRO-VALVULA
10	395379	1	BOBINA	BOBINE	SPULE	COIL	BOBINA
11	395380	1	BOBINA	BOBINE	SPULE	COIL	BOBINA
12	202105	2	VALVOLA	SOUPAPE	VENTIL	VALVE	VALVULA
13	202156	1	CORPO	CORPS	GEHÄUSE	BODY	CUERPO
14	202251	1	ASTA 1° ATTIVAZIONE	TIGE - 1ERE ACTIVATION	STANGE - 1.BETÄTIGUNG	ROD - 1ST ACTIVATION	VARILLA-1ERA ACTIVAC.
15	202251	1	ASTA 2° ATTIVAZIONE	TIGE - 2EME ACTIVATION	STANGE - 2.BETÄTIGUNG	ROD - 2ND ACTIVATION	VARILLA-2DA ACTIVAC.
16	202125	1	DISPOSITIVO DI FERMO	DISPOSITIF D'ARRET	FESTELLVORRICHTUNG	RETAINER DEVICE	DISPOSITIVO DE TOPE
17	202158	2	CORPO	CORPS	GEHÄUSE	BODY	CUERPO
18	202139	1	KIT TIRANTE	KIT TIRANT	ZUGSTANGESATZ	TIE ROD KIT	KIT TIRANTE
19	202255	1	VALVOLA	SOUPAPE	VENTIL	VALVE	VALVULA
20	202274	1	VALVOLA	SOUPAPE	VENTIL	VALVE	VALVULA
21	202179	1	FIANCATA	COTE	SEITENWAND	SIDE PANEL	LADO
22	202233	1	FIANCATA	COTE	SEITENWAND	SIDE PANEL	LADO
A	202348	1	ELEMENTO 2° ATTIVAZIONE	ELEMENT 2E ACTIVATION	2.BETÄTIGUNSELEMENT	2ND ACTIVAT. ELEMENT	ELEMENTO 2A ACTIVAC.
B	202348	1	ELEMENTO 1° ATTIVAZIONE	ELEMENT 1E ACTIVATION	1.BETÄTIGUNSELEMENT	1ST ACTIVAT. ELEMENT	ELEMENTO 1A ACTIVAC.
C	202366	1	ELEMENTO SFILO BRACCI	ELEMENT EXTENS. BRAS	ARMAUSZIEHENELEMENT	ARM EXTENSION ELEMENT	ELEMENT EXT. BRAZOS
D	202365	1	ELEMENTO BRACCIO PRINCIPALE	ELEMENT BRAS PRINCIPAL	HAUPTARMELEMENT	MAIN ARM ELEMENT	ELEM. BRAZO PRINC.



DISTRIBUTORE DANFOSS 5 ELEMENTI - A - 197669 (21)

- * Distributeur DANFOSS - 5 éléments - A
- * DANFOSS-Steuerventilblock - 5 Elemente - A
- * DANFOSS control valve block - 5 elements - A
- * Distribuidor DANFOSS 5 elementos - A

TAV. GN.01.05

matr. G107.0005

21
23 P

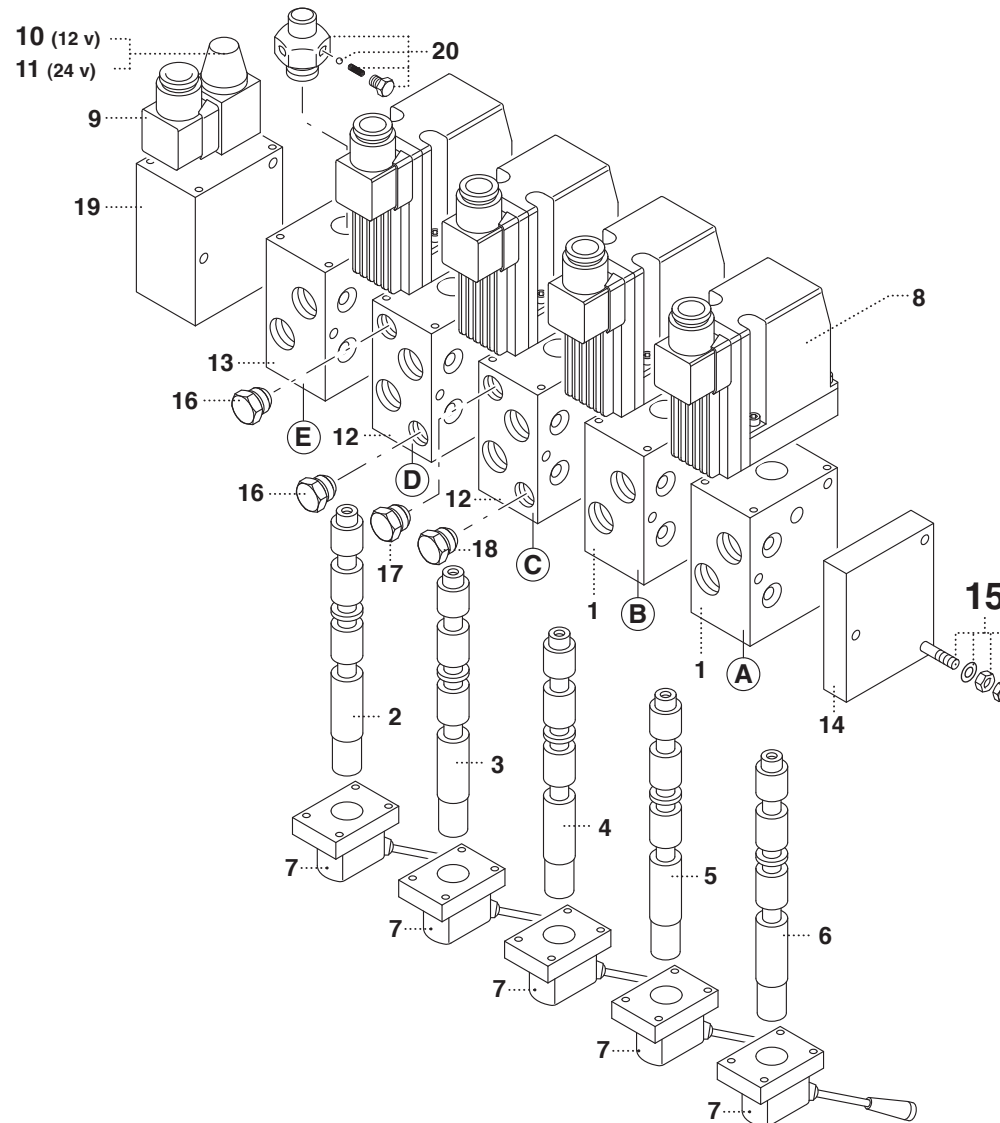

PM 21

matr. G107.0005

TAV. GN.01.05

POS.	N° CODICE	Q.	DESCRIZIONE	DESIGNATION	BENENNUNG	DESCRIPTION	DENOMINACIONES
1	202135	2	CORPO	CORPS	GEHÄUSE	BODY	CUERPO
2	202114	1	ASTA STABILIZZATORE	TIGE STABILISATEUR	STABILISATORSTANGE	STABILISATOR ROD	VARILLA ESTABILIZADOR
3	202280	1	ASTA ROTAZIONE	TIGE ROTATION	DREHSTANGE	ROTATION ROD	VARILLA ROTACION
4	202252	1	ASTA COLONNA	TIGE COLONNE	SÄULESTANGE	COLUMN ROD	VARILLA COLUMNA
5	202221	1	ASTA BRACCIO PRINCIPALE	TIGE BRAS PRINCIPAL	HAUPTARMSTANGE	MAIN ARM ROD	VARILLA BRAZO PRINC.
6	202149	1	ASTA SFILO BRACCI	TIGE EXTENSION BRAS	ARMAUSZIEHENSTANGE	ROD - ARM EXTENSION	VARILLA EXTEN.BRAZOS
7	202123	5	ORGANO DI MANOVRA	DISPOSITIF MOUVEMENT	SCHALTVORRICHTUNG	MOTION DEVICE	ORGANO DE MANOVRA
8	202185	4	MODULO	MODULE	MODULE	MODUL	MODULO
9	204055	1	ELETTROVALVOLA	ELECTROVANNE	ELEKTROVENTIL	ELECTROVALVE	ELECTRO-VALVULA
10	395379	1	BOBINA	BOBINE	SPULE	COIL	BOBINA
11	395380	1	BOBINA	BOBINE	SPULE	COIL	BOBINA
12	202158	2	CORPO	CORPS	GEHÄUSE	BODY	CUERPO
13	202156	1	CORPO	CORPS	GEHÄUSE	BODY	CUERPO
14	202233	1	FIANCATA	COTE	SEITENWAND	SIDE PANEL	LADO
15	202162	1	KIT TIRANTE	KIT TIRANT	ZUGSTANGESATZ	TIE ROD KIT	KIT TIRANTE
16	202105	2	VALVOLA	SOUPAPE	VENTIL	VALVE	VALVULA
17	202255	1	VALVOLA	SOUPAPE	VENTIL	VALVE	VALVULA
18	202274	1	VALVOLA	SOUPAPE	VENTIL	VALVE	VALVULA
19	202179	1	FIANCATA	COTE	SEITENWAND	SIDE PANEL	LADO
20	202125	1	DISPOSITIVO DI FERMO	DISPOSITIF D'ARRET	FESTELLVORRICHTUNG	RETAINER DEVICE	DISPOSITIVO DE TOPE
A	202362	1	ELEMENTO SFILO BRACCI	ELEMENT EXTENS. BRAS	ARMAUSZIEHENELEMENT	ARM EXTENSION ELEMENT	ELEMENT EXT. BRAZOS
B	202361	1	ELEMENTO BRACCIO PRINCIPALE	ELEMENT BRAS PRINCIPAL	HAUPTARMELEMENT	MAIN ARM ELEMENT	ELEM. BRAZO PRINC.
C	364360	1	ELEMENTO COLONNA	ELEMENT COLONNE	SÄULEELEMENT	COLUMN ELEMENT	ELEMENTO COLUMNA
D	202359	1	ELEMENTO ROTAZIONE	ELEMENT ROTATION	DREHUNGELEMENT	ROTATION ELEMENT	ELEMENTO ROTACION
E	202143	1	ELEMENTO STABILIZZATORE	ELEMENT STABILISATEUR	STABILISATORELEMENT	STABILISATOR ELEMENT	ELEM. ESTABILIZADOR

PM 21

matr. G107.0005

TAV. GN.01.06

POS.	N° CODICE	Q.	DESCRIZIONE	DESIGNATION	BENENNUNG	DESCRIPTION	DENOMINACIONES
1	202135	3	CORPO	CORPS	GEHÄUSE	BODY	CUERPO
2	202114	1	ASTA STABILIZZATORE	TIGE STABILISATEUR	STABILISATORSTANGE	STABILISATOR ROD	VARILLA ESTABILIZADOR
3	202280	1	ASTA ROTAZIONE	TIGE ROTATION	DREHSTANGE	ROTATION ROD	VARILLA ROTACION
4	202252	1	ASTA COLONNA	TIGE COLONNE	SÄULESTANGE	COLUMN ROD	VARILLA COLUMNA
5	202221	1	ASTA BRACCIO PRINCIPALE	TIGE BRAS PRINCIPAL	HAUPTARMSTANGE	MAIN ARM ROD	VARILLA BRAZO PRINC.
6	202149	1	ASTA SFILO BRACCI	TIGE EXTENSION BRAS	ARMAUSZIEHENSTANGE	ROD - ARM EXTENSION	VARILLA EXTEN.BRAZOS
7	202123	6	ORGANO DI MANOVRA	DISPOSITIF MOUVEMENT	SCHALTVORRICHTUNG	MOTION DEVICE	ORGANO DE MANOVRA
8	202185	5	MODULO	MODULE	MODULE	MODUL	MODULO
9	204055	1	ELETTROVALVOLA	ELECTROVANNE	ELEKTROVENTIL	ELECTROVALVE	ELECTRO-VALVULA
10	395379	1	BOBINA	BOBINE	SPULE	COIL	BOBINA
11	395380	1	BOBINA	BOBINE	SPULE	COIL	BOBINA
12	202105	2	VALVOLA	SOUPAPE	VENTIL	VALVE	VALVULA
13	202156	1	CORPO	CORPS	GEHÄUSE	BODY	CUERPO
14	202251	1	ASTA 1° ATTIVAZIONE	TIGE - 1ERE ACTIVATION	STANGE - 1.BETÄTIGUNG	ROD - 1ST ACTIVATION	VARILLA-1ERA ACTIVAC.
15	202125	1	DISPOSITIVO DI FERMO	DISPOSITIF D'ARRET	FESTELLVORRICHTUNG	RETAINER DEVICE	DISPOSITIVO DE TOPE
16	202158	2	CORPO	CORPS	GEHÄUSE	BODY	CUERPO
17	202138	1	KIT TIRANTE	KIT TIRANT	ZUGSTANGESATZ	TIE ROD KIT	KIT TIRANTE
18	202255	1	VALVOLA	SOUPAPE	VENTIL	VALVE	VALVULA
19	202274	1	VALVOLA	SOUPAPE	VENTIL	VALVE	VALVULA
20	202179	1	FIANCATA	COTE	SEITENWAND	SIDE PANEL	LADO
21	202233	1	FIANCATA	COTE	SEITENWAND	SIDE PANEL	LADO
A	202358	1	ELEMENTO 1° ATTIVAZIONE	ELEMENT 1E ACTIVATION	1.BETÄTIGUNSELEMENT	1ST ACTIVAT. ELEMENT	ELEMENTO 1A ACTIVAC.
B	202362	1	ELEMENTO SFILO BRACCI	ELEMENT EXTENS. BRAS	ARMAUSZIEHENELEMENT	ARM EXTENSION ELEMENT	ELEMENT EXT. BRAZOS
C	202361	1	ELEMENTO BRACCIO PRINCIPALE	ELEMENT BRAS PRINCIPAL	HAUPTARMELEMENT	MAIN ARM ELEMENT	ELEM. BRAZO PRINC.
D	202360	1	ELEMENTO COLONNA	ELEMENT COLONNE	SÄULEELEMENT	COLUMN ELEMENT	ELEMENTO COLUMNA
E	202359	1	ELEMENTO ROTAZIONE	ELEMENT ROTATION	DREHUNGELEMENT	ROTATION ELEMENT	ELEMENTO ROTACION



DISTRIBUTORE DANFOSS 6 ELEMENTI - A - 1° ATTIVAZIONE - 197671 (21)

* Distributeur DANFOSS - 6 éléments - A 1ère activation
* DANFOSS-Steuerventilblock - 6 Elemente - A - 1. Betätigung
* DANFOSS control valve block - 6 elements - A - 1st activation
* Distribuidor DANFOSS 6 elementos - A - 1era activación

TAV. GN.01.06

matr. G107.0005

21
23 P

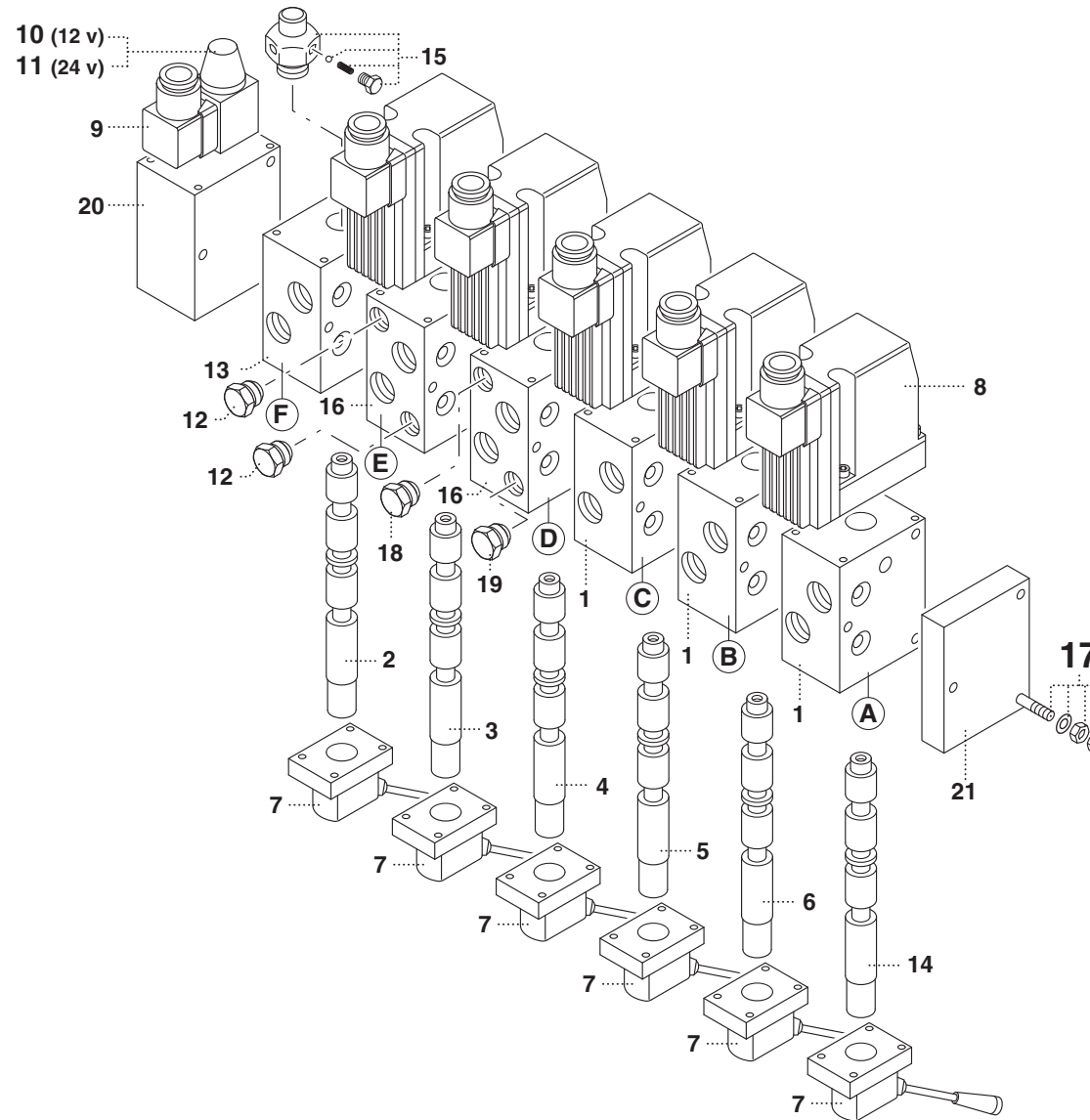



DISTRIBUTORE DANFOSS 6 ELEMENTI A - ARGANO - 197670 (21)

* Distributeur DANFOSS - 6 éléments A - treuil
* DANFOSS-Steuerventilblock - 6 Elemente A - Winde
* DANFOSS control valve block - 6 elements A - winch
* Distribuidor DANFOSS 6 elementos A - cabrestante

TAV. GN.01.07

matr. G107.0005

21
23 P

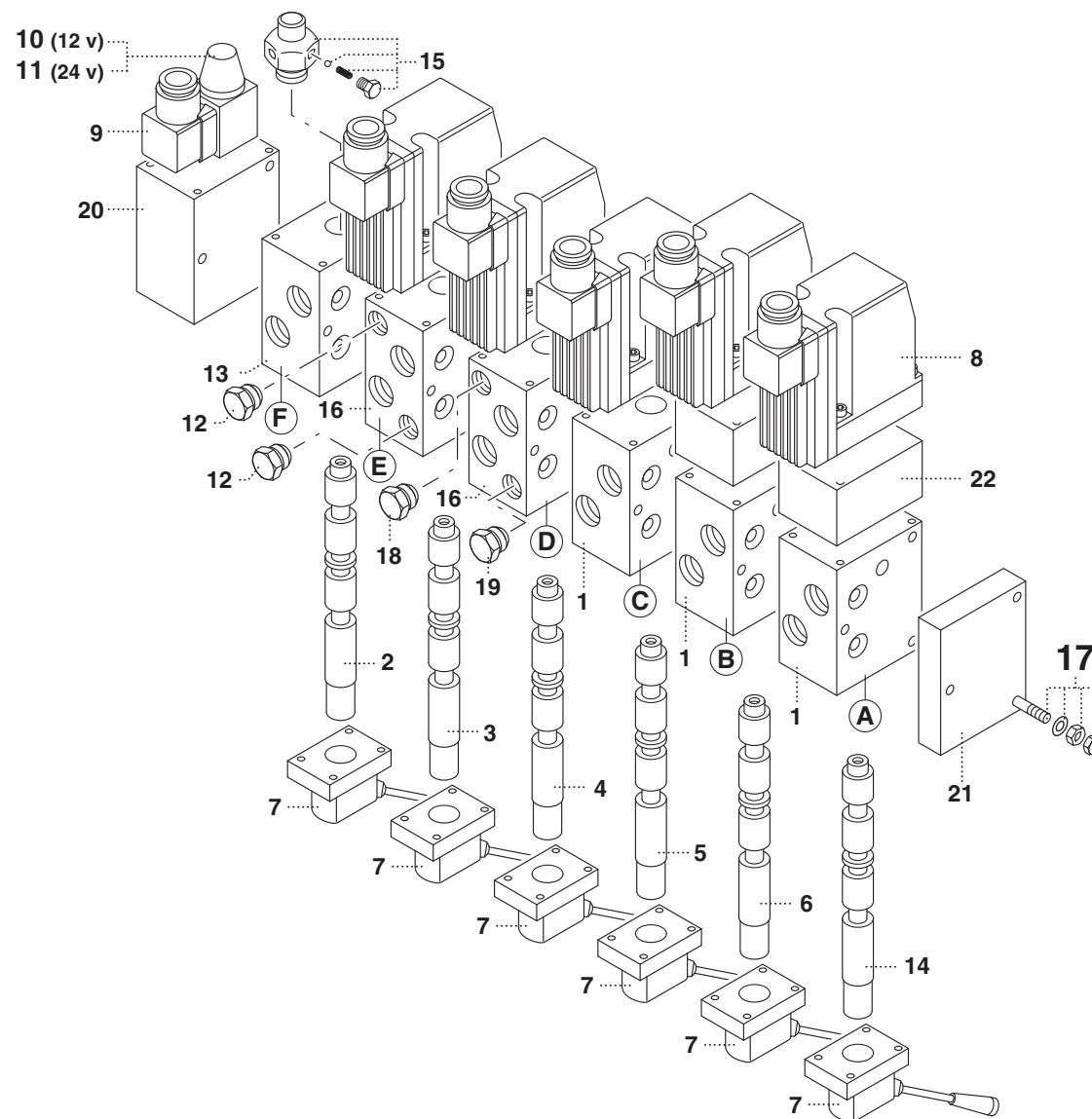

PM 21

matr. G107.0005

TAV. GN.01.07

POS.	N° CODICE	Q.	DESCRIZIONE	DESIGNATION	BENENNUNG	DESCRIPTION	DENOMINACIONES
1	202135	3	CORPO	CORPS	GEHÄUSE	BODY	CUERPO
2	202114	1	ASTA STABILIZZATORE	TIGE STABILISATEUR	STABILISATORSTANGE	STABILISATOR ROD	VARILLA ESTABILIZADOR
3	202280	1	ASTA ROTAZIONE	TIGE ROTATION	DREHSTANGE	ROTATION ROD	VARILLA ROTACION
4	202252	1	ASTA COLONNA	TIGE COLONNE	SÄULESTANGE	COLUMN ROD	VARILLA COLUMNA
5	202221	1	ASTA BRACCIO PRINCIPALE	TIGE BRAS PRINCIPAL	HAUPTARMSTANGE	MAIN ARM ROD	VARILLA BRAZO PRINC.
6	202149	1	ASTA SFILO BRACCI	TIGE EXTENSION BRAS	ARMAUSZIEHENSTANGE	ROD - ARM EXTENSION	VARILLA EXTEN.BRAZOS
7	202123	6	ORGANO DI MANOVRA	DISPOSITIF MOUVEMENT	SCHALTVORRICHTUNG	MOTION DEVICE	ORGANO DE MANOVRA
8	202185	5	MODULO	MODULE	MODULE	MODUL	MODULO
9	204055	1	ELETTROVALVOLA	ELECTROVANNE	ELEKTROVENTIL	ELECTROVALVE	ELECTRO-VALVULA
10	395379	1	BOBINA	BOBINE	SPULE	COIL	BOBINA
11	395380	1	BOBINA	BOBINE	SPULE	COIL	BOBINA
12	202105	2	VALVOLA	SOUPAPE	VENTIL	VALVE	VALVULA
13	202156	1	CORPO	CORPS	GEHÄUSE	BODY	CUERPO
14	202130	1	ASTA ARGANO	TIGE TREUIL	WINDESTANGE	WINCH ROD	VARILLA CABRESANTE
15	202125	1	DISPOSITIVO DI FERMO	DISPOSITIF D'ARRET	FESTELLVORRICHTUNG	RETAINER DEVICE	DISPOSITIVO DE TOPE
16	202158	2	CORPO	CORPS	GEHÄUSE	BODY	CUERPO
17	202138	1	KIT TIRANTE	KIT TIRANT	ZUGSTANGESATZ	TIE ROD KIT	KIT TIRANTE
18	202255	1	VALVOLA	SOUPAPE	VENTIL	VALVE	VALVULA
19	202274	1	VALVOLA	SOUPAPE	VENTIL	VALVE	VALVULA
20	202179	1	FIANCATA	COTE	SEITENWAND	SIDE PANEL	LADO
21	202233	1	FIANCATA	COTE	SEITENWAND	SIDE PANEL	LADO
22	202172	2	MODULO	MODULE	MODULE	MODUL	MODULO
A	202368	1	ELEMENTO ARGANO	ELEMENT TREUIL	WINDEELEMENT	WINCH ELEMENT	ELEM. CABRESTANTE
B	202367	1	ELEMENTO SFILO BRACCI	ELEMENT EXTENS. BRAS	ARMAUSZIEHENELEMENT	ARM EXTENSION ELEMENT	ELEMENT EXT. BRAZOS
C	202361	1	ELEMENTO BRACCIO PRINCIPALE	ELEMENT BRAS PRINCIPAL	HAUPTARMELEMENT	MAIN ARM ELEMENT	ELEM. BRAZO PRINC.
D	202360	1	ELEMENTO COLONNA	ELEMENT COLONNE	SÄULEELEMENT	COLUMN ELEMENT	ELEMENTO COLUMNA



DISTRIBUTORE DANFOSS 6 ELEMENTI A - ARGANO - 197670 (21)

- * Distributeur DANFOSS - 6 éléments A - treuil
- * DANFOSS-Steuerventilblock - 6 Elemente A - Winde
- * DANFOSS control valve block - 6 elements A - winch
- * Distribuidor DANFOSS 6 elementos A - cabrestante

TAV. GN.01.07

matr. G107.0005

21
23 P

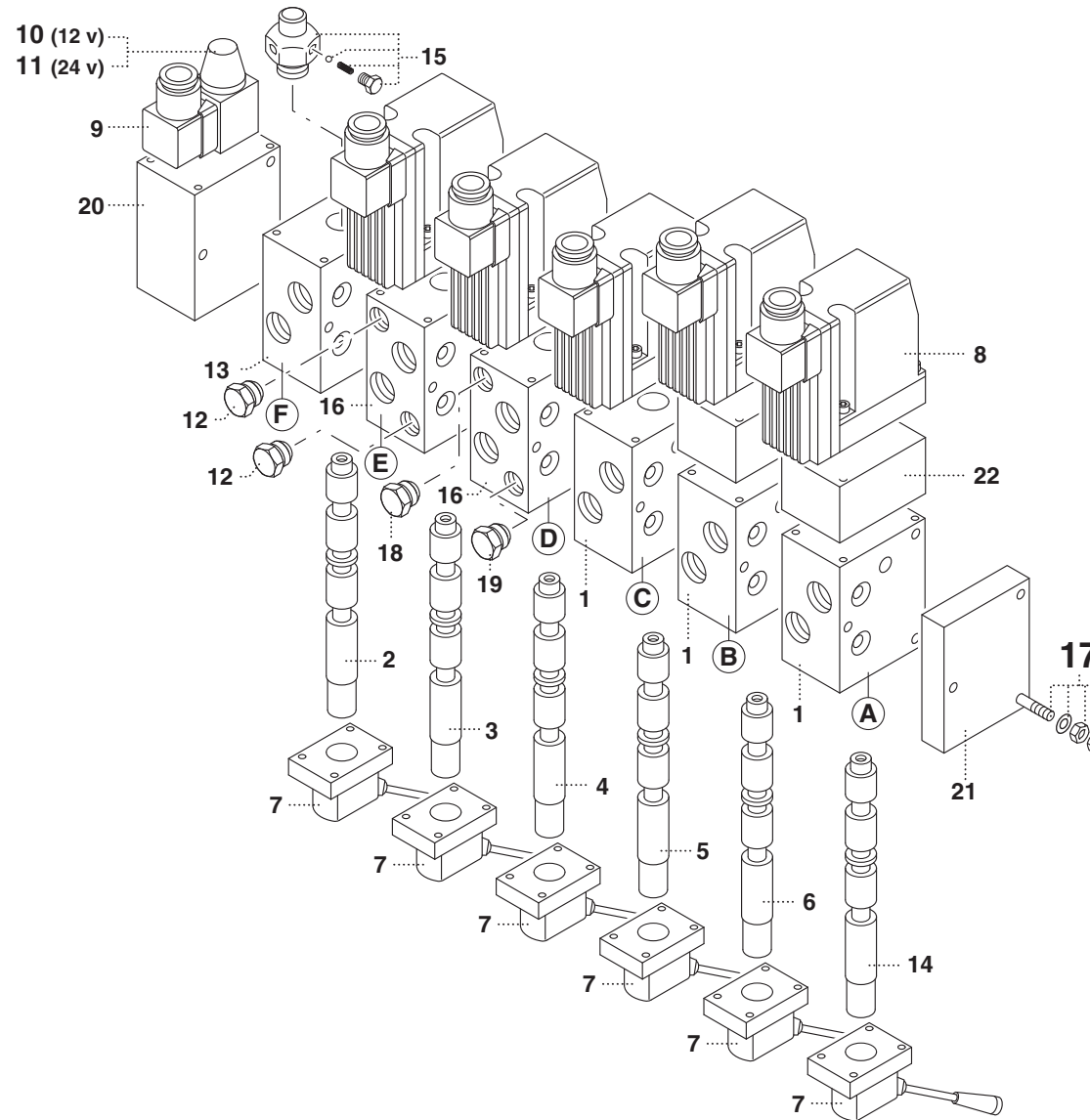



DISTRIBUTORE DANFOSS 7 ELEMENTI - A - 2° ATTIVAZIONE - 197672 (21)

* Distributeur DANFOSS - 7 éléments - A 2ème activation
* DANFOSS-Steuerventilblock - 7 Elemente - A - 2. Betätigung
* DANFOSS control valve block - 7 elements - A - 2nd activation
* Distribuidor DANFOSS 7 elementos - A - 2da activación

TAV. GN.01.08

matr. G107.0005

21
23 P

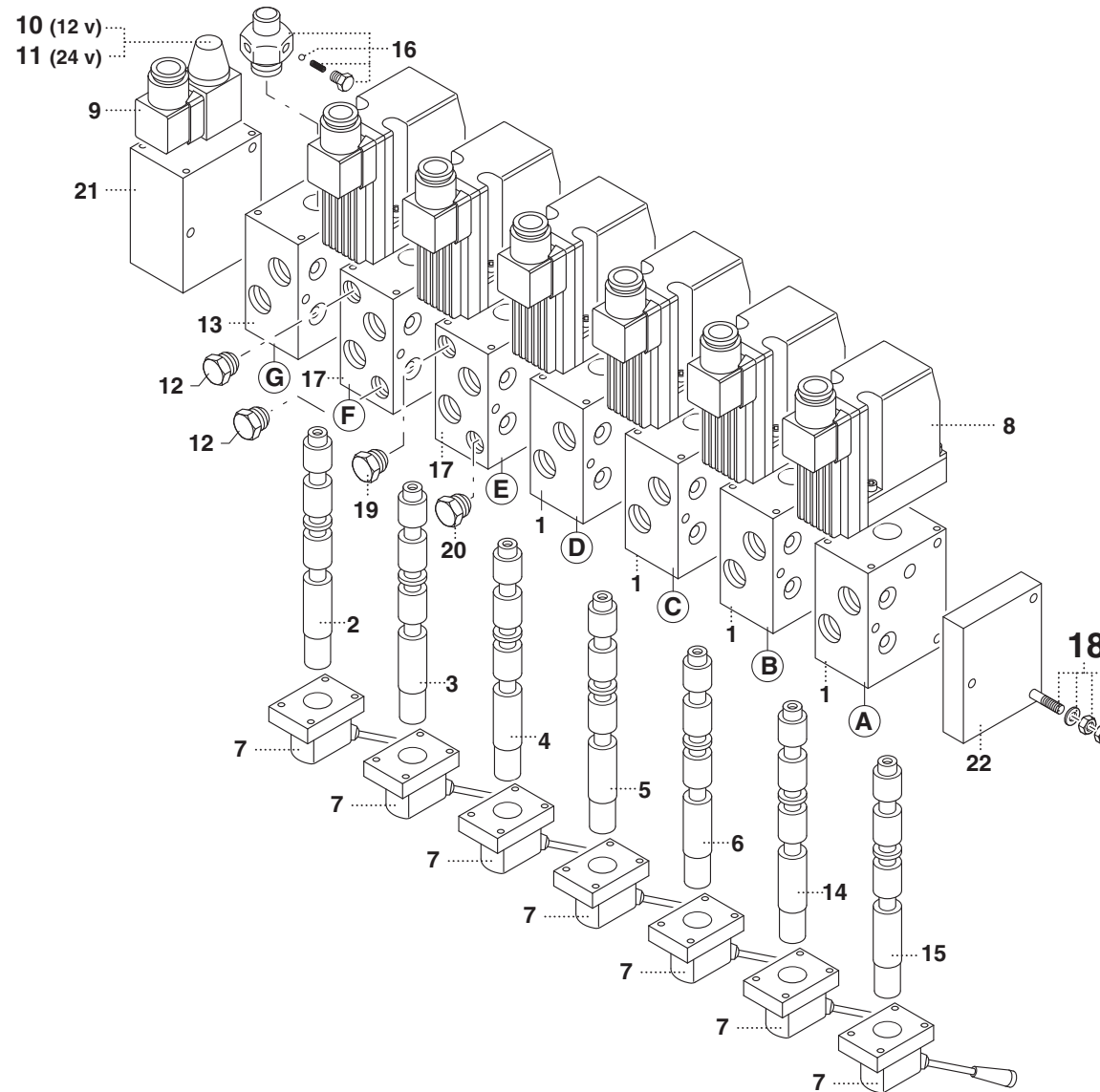

PM 21

matr. G107.0005

TAV. GN.01.08

POS.	N° CODICE	Q.	DESCRIZIONE	DESIGNATION	BENENNUNG	DESCRIPTION	DENOMINACIONES
1	202135	4	CORPO	CORPS	GEHÄUSE	BODY	CUERPO
2	202114	1	ASTA STABILIZZATORE	TIGE STABILISATEUR	STABILISATORSTANGE	STABILISATOR ROD	VARILLA ESTABILIZADOR
3	202280	1	ASTA ROTAZIONE	TIGE ROTATION	DREHSTANGE	ROTATION ROD	VARILLA ROTACION
4	202252	1	ASTA COLONNA	TIGE COLONNE	SÄULESTANGE	COLUMN ROD	VARILLA COLUMNA
5	202221	1	ASTA BRACCIO PRINCIPALE	TIGE BRAS PRINCIPAL	HAUPTARMSTANGE	MAIN ARM ROD	VARILLA BRAZO PRINC.
6	202149	1	ASTA SFILO BRACCI	TIGE EXTENSION BRAS	ARMAUSZIEHENSTANGE	ROD - ARM EXTENSION	VARILLA EXTEN.BRAZOS
7	202123	7	ORGANO DI MANOVRA	DISPOSITIF MOUVEMENT	SCHALTVORRICHTUNG	MOTION DEVICE	ORGANO DE MANOVRA
8	202185	6	MODULO	MODULE	MODULE	MODUL	MODULO
9	204055	1	ELETTROVALVOLA	ELECTROVANNE	ELEKTROVENTIL	ELECTROVALVE	ELECTRO-VALVULA
10	395379	1	BOBINA	BOBINE	SPULE	COIL	BOBINA
11	395380	1	BOBINA	BOBINE	SPULE	COIL	BOBINA
12	202105	2	VALVOLA	SOUPAPE	VENTIL	VALVE	VALVULA
13	202156	1	CORPO	CORPS	GEHÄUSE	BODY	CUERPO
14	202251	1	ASTA 1° ATTIVAZIONE	TIGE - 1ERE ACTIVATION	STANGE - 1.BETÄTIGUNG	ROD - 1ST ACTIVATION	VARILLA-1ERA ACTIVAC.
15	202251	1	ASTA 2° ATTIVAZIONE	TIGE - 2EME ACTIVATION	STANGE - 2.BETÄTIGUNG	ROD - 2ND ACTIVATION	VARILLA-2DA ACTIVAC.
16	202125	1	DISPOSITIVO DI FERMO	DISPOSITIF D'ARRET	FESTELLVORRICHTUNG	RETAINER DEVICE	DISPOSITIVO DE TOPE
17	202158	2	CORPO	CORPS	GEHÄUSE	BODY	CUERPO
18	202139	1	KIT TIRANTE	KIT TIRANT	ZUGSTANGESATZ	TIE ROD KIT	KIT TIRANTE
19	202255	1	VALVOLA	SOUPAPE	VENTIL	VALVE	VALVULA
20	202274	1	VALVOLA	SOUPAPE	VENTIL	VALVE	VALVULA
21	202179	1	FIANCATA	COTE	SEITENWAND	SIDE PANEL	LADO
22	202233	1	FIANCATA	COTE	SEITENWAND	SIDE PANEL	LADO
A	202358	1	ELEMENTO 2° ATTIVAZIONE	ELEMENT 2E ACTIVATION	2.BETÄTIGUNSELEMENT	2ND ACTIVAT. ELEMENT	ELEMENTO 2A ACTIVAC.
B	202358	1	ELEMENTO 1° ATTIVAZIONE	ELEMENT 1E ACTIVATION	1.BETÄTIGUNSELEMENT	1ST ACTIVAT. ELEMENT	ELEMENTO 1A ACTIVAC.
C	202362	1	ELEMENTO SFILO BRACCI	ELEMENT EXTENS. BRAS	ARMAUSZIEHENELEMENT	ARM EXTENSION ELEMENT	ELEMENT EXT. BRAZOS
D	202361	1	ELEMENTO BRACCIO PRINCIPALE	ELEMENT BRAS PRINCIPAL	HAUPTARMELEMENT	MAIN ARM ELEMENT	ELEM. BRAZO PRINC.



DISTRIBUTORE DANFOSS 7 ELEMENTI - A - 2° ATTIVAZIONE - 197672 (21)

* Distributeur DANFOSS - 7 éléments - A 2ème activation
* DANFOSS-Steuerventilblock - 7 Elemente - A - 2. Betätigung
* DANFOSS control valve block - 7 elements - A - 2nd activation
* Distribuidor DANFOSS 7 elementos - A - 2da activación

TAV. GN.01.08

matr. G107.0005

21
23 P

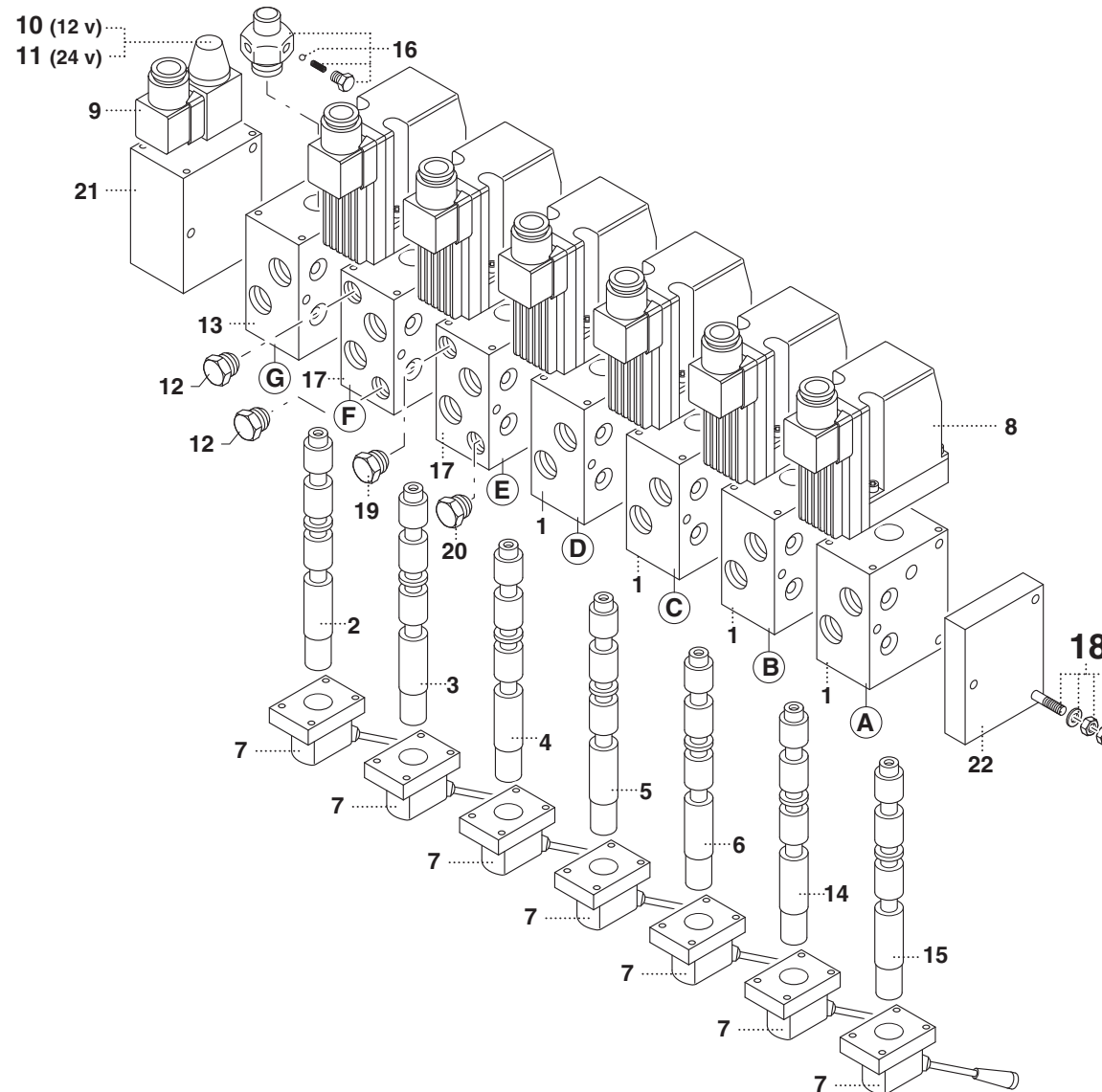



DISTRIBUTORE DANFOSS 4 ELEMENTI - H - 197568 (23 P)

- * Distributeur DANFOSS - 4 éléments - H
- * DANFOSS-Steuerventilblock - 4 Elemente - H
- * DANFOSS control valve block - 4 elements - H
- * Distribuidor DANFOSS 4 elementos - H

TAV. GN.02.01

matr. G107.0005

21
23 P

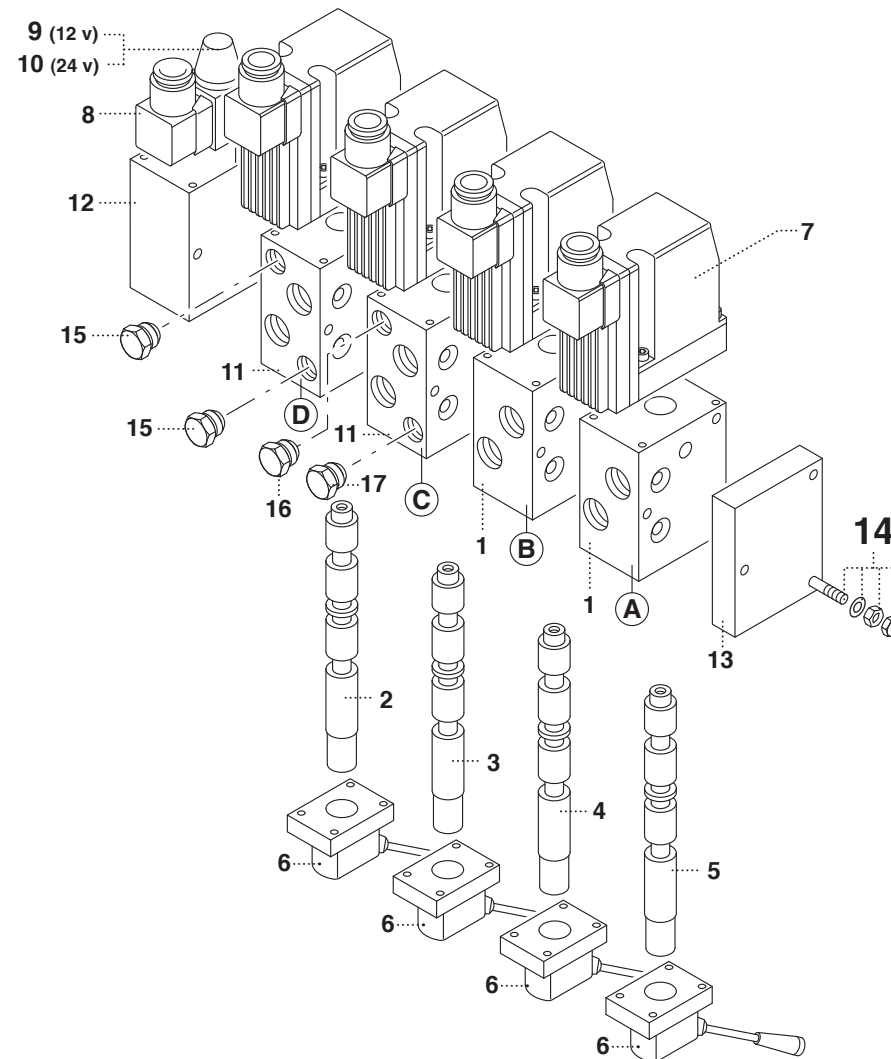

PM 23 P

matr. G107.0005

TAV. GN.02.01

POS.	N° CODICE	Q.	DESCRIZIONE	DESIGNATION	BENENNUNG	DESCRIPTION	DENOMINACIONES
1	202135	2	CORPO	CORPS	GEHÄUSE	BODY	CUERPO
2	202280	1	ASTA ROTAZIONE	TIGE ROTATION	DREHSTANGE	ROTATION ROD	VARILLA ROTACION
3	202252	1	ASTA COLONNA	TIGE COLONNE	SÄULESTANGE	COLUMN ROD	VARILLA COLUMNNA
4	202221	1	ASTA BRACCIO PRINCIPALE	TIGE BRAS PRINCIPAL	HAUPTARMSTANGE	MAIN ARM ROD	VARILLA BRAZO PRINC.
5	202149	1	ASTA SFILO BRACCI	TIGE EXTENSION BRAS	ARMAUSZIEHENSTANGE	ROD - ARM EXTENSION	VARILLA EXTEN.BRAZOS
6	202123	4	ORGANO DI MANOVRA	DISPOSITIF MOUVEMENT	SCHALTVORRICHTUNG	MOTION DEVICE	ORGANO DE MANOVRA
7	202347	4	MODULO	MODULE	MODULE	MODUL	MODULO
8	204055	1	ELETTROVALVOLA	ELECTROVANNE	ELEKTROVENTIL	ELECTROVALVE	ELECTRO-VALVULA
9	395379	1	BOBINA	BOBINE	SPULE	COIL	BOBINA
10	395380	1	BOBINA	BOBINE	SPULE	COIL	BOBINA
11	202158	2	CORPO	CORPS	GEHÄUSE	BODY	CUERPO
12	202179	1	FIANCATA	COTE	SEITENWAND	SIDE PANEL	LADO
13	202233	1	FIANCATA	COTE	SEITENWAND	SIDE PANEL	LADO
14	202168	1	KIT TIRANTE	KIT TIRANT	ZUGSTANGESATZ	TIE ROD KIT	KIT TIRANTE
15	202105	2	VALVOLA	SOUPAPE	VENTIL	VALVE	VALVULA
16	202255	1	VALVOLA	SOUPAPE	VENTIL	VALVE	VALVULA
17	202274	1	VALVOLA	SOUPAPE	VENTIL	VALVE	VALVULA
A	202344	1	ELEMENTO SFILO BRACCI	ELEMENT EXTENS. BRAS	ARMAUSZIEHENELEMENT	ARM EXTENSION ELEMENT	ELEMENT EXT. BRAZOS
B	202343	1	ELEMENTO BRACCIO PRINCIPALE	ELEMENT BRAS PRINCIPAL	HAUPTARMELEMENT	MAIN ARM ELEMENT	ELEM. BRAZO PRINC.
C	202342	1	ELEMENTO COLONNA	ELEMENT COLONNE	SÄULEELEMENT	COLUMN ELEMENT	ELEMENTO COLUMNNA
D	202341	1	ELEMENTO ROTAZIONE	ELEMENT ROTATION	DREHUNGELEMENT	ROTATION ELEMENT	ELEMENTO ROTACION



DISTRIBUTORE DANFOSS 5 ELEMENTI - H - 1° ATTIVAZIONE - 497569 (23 P)

* Distributeur DANFOSS - 5 éléments - H 1ère activation
* DANFOSS-Steuerventilblock - 5 Elemente - H - 1. Betätigung
* DANFOSS control valve block - 5 elements - H - 1st activation
* Distribuidor DANFOSS 5 elementos - H - 1era activación

TAV. GN.02.02

matr. G107.0005

21
23 P

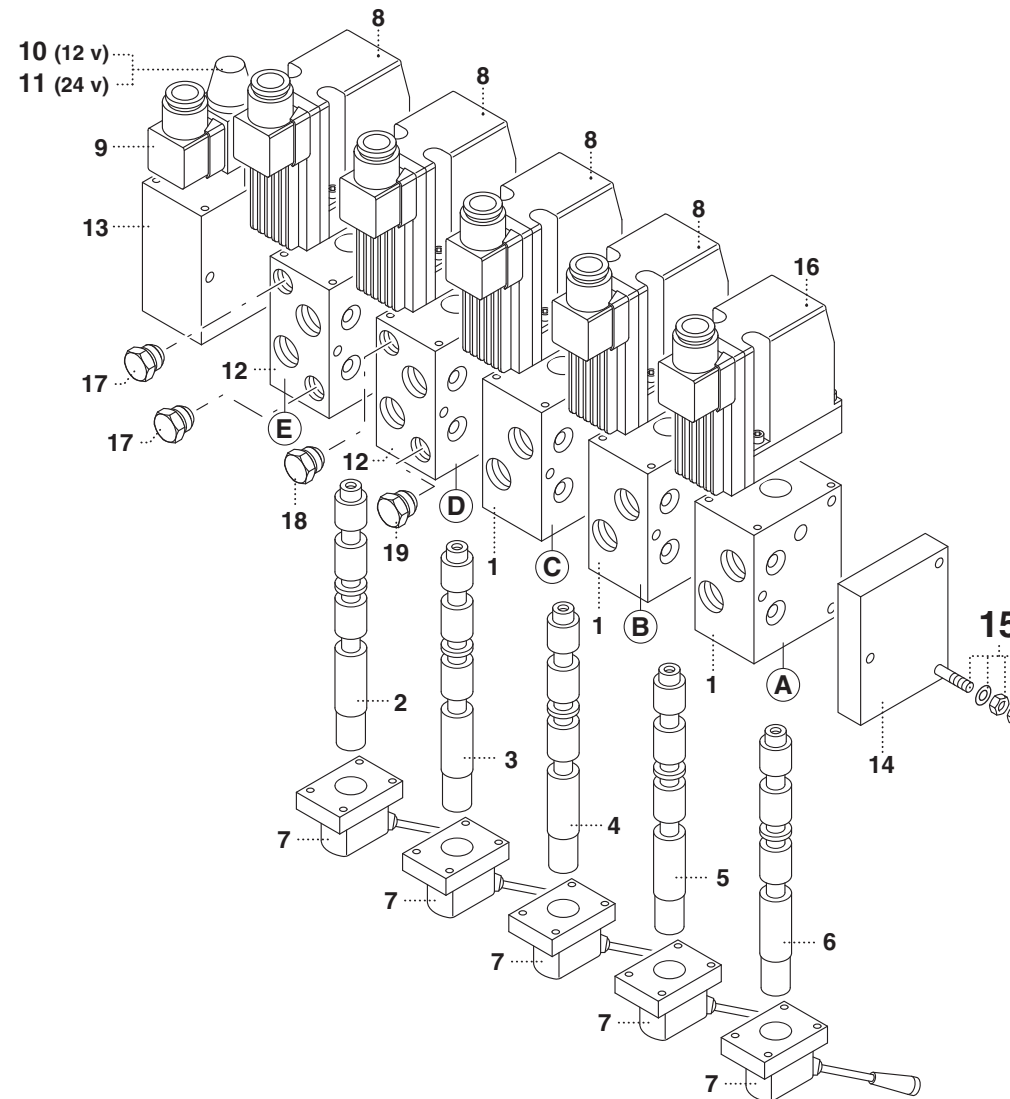

PM 23 P

matr. G107.0005

TAV. GN.02.02

POS.	N° CODICE	Q.	DESCRIZIONE	DESIGNATION	BENENNUNG	DESCRIPTION	DENOMINACIONES
1	202135	3	CORPO	CORPS	GEHÄUSE	BODY	CUERPO
2	202280	1	ASTA ROTAZIONE	TIGE ROTATION	DREHSTANGE	ROTATION ROD	VARILLA ROTACION
3	202252	1	ASTA COLONNA	TIGE COLONNE	SÄULESTANGE	COLUMN ROD	VARILLA COLUMNNA
4	202221	1	ASTA BRACCIO PRINCIPALE	TIGE BRAS PRINCIPAL	HAUPTARMSTANGE	MAIN ARM ROD	VARILLA BRAZO PRINC.
5	202149	1	ASTA SFILO BRACCI	TIGE EXTENSION BRAS	ARMAUSZIEHENSTANGE	ROD - ARM EXTENSION	VARILLA EXTEN.BRAZOS
6	202251	1	ASTA 1° ATTIVAZIONE	TIGE - 1ERE ACTIVATION	STANGE - 1.BETÄTIGUNG	ROD - 1ST ACTIVATION	VARILLA-1ERA ACTIVAC.
7	202123	5	ORGANO DI MANOVRA	DISPOSITIF MOUVEMENT	SCHALTVORRICHTUNG	MOTION DEVICE	ORGANO DE MANOVRA
8	202347	4	MODULO	MODULE	MODULE	MODUL	MODULO
9	204055	1	ELETTROVALVOLA	ELECTROVANNE	ELEKTROVENTIL	ELECTROVALVE	ELECTRO-VALVULA
10	395379	1	BOBINA	BOBINE	SPULE	COIL	BOBINA
11	395380	1	BOBINA	BOBINE	SPULE	COIL	BOBINA
12	202158	2	CORPO	CORPS	GEHÄUSE	BODY	CUERPO
13	202179	1	FIANCATA	COTE	SEITENWAND	SIDE PANEL	LADO
14	202233	1	FIANCATA	COTE	SEITENWAND	SIDE PANEL	LADO
15	202162	1	KIT TIRANTE	KIT TIRANT	ZUGSTANGESATZ	TIE ROD KIT	KIT TIRANTE
16	202219	1	MODULO	MODULE	MODULE	MODUL	MODULO
17	202105	2	VALVOLA	SOUPAPE	VENTIL	VALVE	VALVULA
18	202255	1	VALVOLA	SOUPAPE	VENTIL	VALVE	VALVULA
19	202274	1	VALVOLA	SOUPAPE	VENTIL	VALVE	VALVULA
A	202348	1	ELEMENTO 1° ATTIVAZIONE	ELEMENT 1E ACTIVATION	1.BETÄTIGUNSELEMENT	1ST ACTIVAT. ELEMENT	ELEMENTO 1A ACTIVAC.
B	202344	1	ELEMENTO SFILO BRACCI	ELEMENT EXTENS. BRAS	ARMAUSZIEHENELEMENT	ARM EXTENSION ELEMENT	ELEMENT EXT. BRAZOS
C	202343	1	ELEMENTO BRACCIO PRINCIPALE	ELEMENT BRAS PRINCIPAL	HAUPTARMELEMENT	MAIN ARM ELEMENT	ELEM. BRAZO PRINC.
D	202342	1	ELEMENTO COLONNA	ELEMENT COLONNE	SÄULEELEMENT	COLUMN ELEMENT	ELEMENTO COLUMNNA
E	202341	1	ELEMENTO ROTAZIONE	ELEMENT ROTATION	DREHUNGELEMENT	ROTATION ELEMENT	ELEMENTO ROTACION



DISTRIBUTORE DANFOSS 5 ELEMENTI H - ARGANO - 197571 (23 P)

* Distributeur DANFOSS - 5 éléments H - treuil
* DANFOSS-Steuerventilblock - 5 Elemente H - Winde
* DANFOSS control valve block - 5 elements H - winch
* Distribuidor DANFOSS 5 elementos H - cabrestante

TAV. GN.02.03

matr. G107.0005

21
23 P

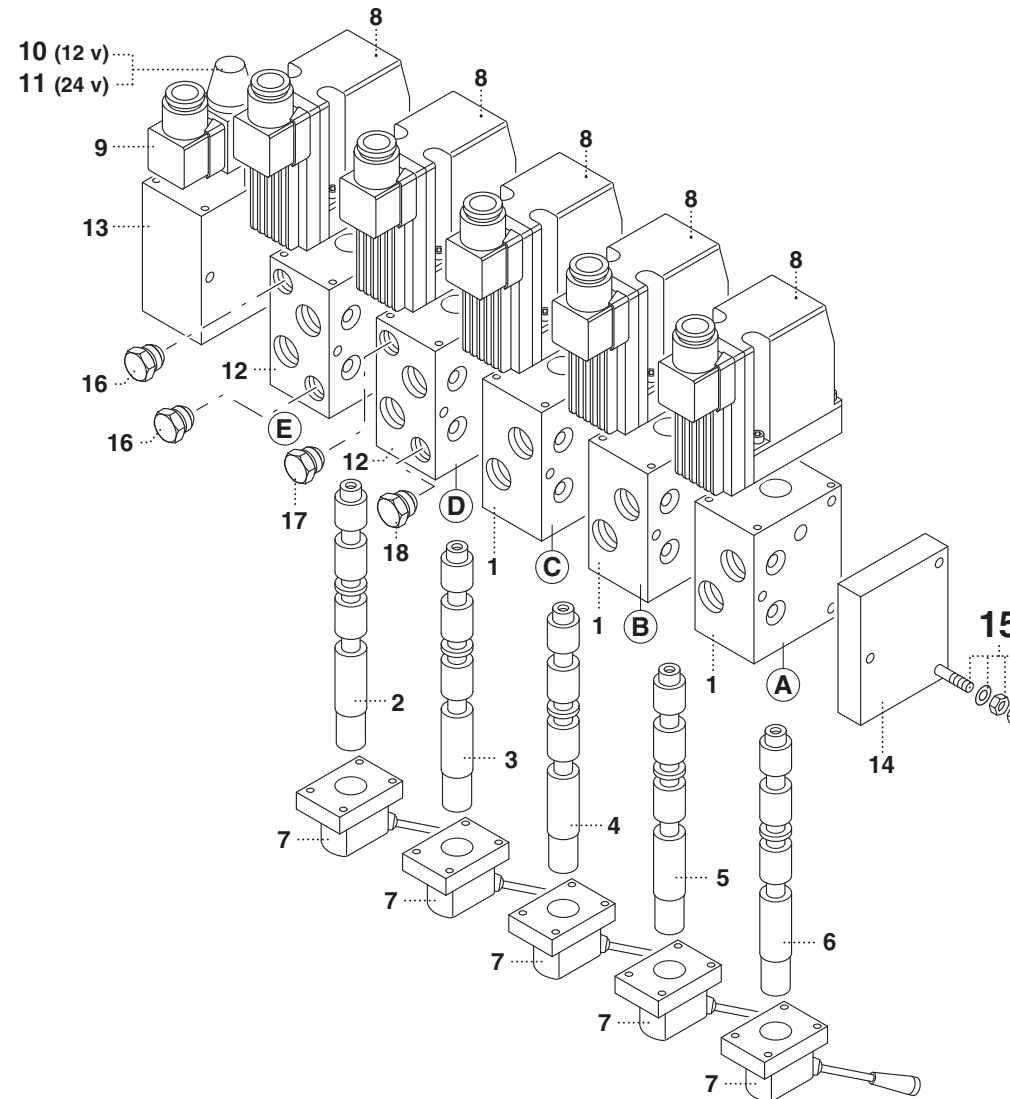

PM 23 P

matr. G107.0005

TAV. GN.02.03

POS.	N° CODICE	Q.	DESCRIZIONE	DESIGNATION	BENENNUNG	DESCRIPTION	DENOMINACIONES
1	202135	3	CORPO	CORPS	GEHÄUSE	BODY	CUERPO
2	202280	1	ASTA ROTAZIONE	TIGE ROTATION	DREHSTANGE	ROTATION ROD	VARILLA ROTACION
3	202252	1	ASTA COLONNA	TIGE COLONNE	SÄULESTANGE	COLUMN ROD	VARILLA COLUMNNA
4	202221	1	ASTA BRACCIO PRINCIPALE	TIGE BRAS PRINCIPAL	HAUPTARMSTANGE	MAIN ARM ROD	VARILLA BRAZO PRINC.
5	202149	1	ASTA SFILO BRACCI	TIGE EXTENSION BRAS	ARMAUSZIEHENSTANGE	ROD - ARM EXTENSION	VARILLA EXTEN.BRAZOS
6	202130	1	ASTA ARGANO	TIGE TREUIL	WINDESTANGE	WINCH ROD	VARILLA CABRESANTE
7	202123	5	ORGANO DI MANOVRA	DISPOSITIF MOUVEMENT	SCHALTVORRICHTUNG	MOTION DEVICE	ORGANO DE MANOVRA
8	202347	5	MODULO	MODULE	MODULE	MODUL	MODULO
9	204055	1	ELETTROVALVOLA	ELECTROVANNE	ELEKTROVENTIL	ELECTROVALVE	ELECTRO-VALVULA
10	395379	1	BOBINA	BOBINE	SPULE	COIL	BOBINA
11	395380	1	BOBINA	BOBINE	SPULE	COIL	BOBINA
12	202158	2	CORPO	CORPS	GEHÄUSE	BODY	CUERPO
13	202179	1	FIANCATA	COTE	SEITENWAND	SIDE PANEL	LADO
14	202233	1	FIANCATA	COTE	SEITENWAND	SIDE PANEL	LADO
15	202162	1	KIT TIRANTE	KIT TIRANT	ZUGSTANGESATZ	TIE ROD KIT	KIT TIRANTE
16	202105	2	VALVOLA	SOUPAPE	VENTIL	VALVE	VALVULA
17	202255	1	VALVOLA	SOUPAPE	VENTIL	VALVE	VALVULA
18	202274	1	VALVOLA	SOUPAPE	VENTIL	VALVE	VALVULA
A	202345	1	ELEMENTO ARGANO	ELEMENT TREUIL	WINDEELEMENT	WINCH ELEMENT	ELEM. CABRESTANTE
B	202344	1	ELEMENTO SFILO BRACCI	ELEMENT EXTENS. BRAS	ARMAUSZIEHENELEMENT	ARM EXTENSION ELEMENT	ELEMENT EXT. BRAZOS
C	202343	1	ELEMENTO BRACCIO PRINCIPALE	ELEMENT BRAS PRINCIPAL	HAUPTARMELEMENT	MAIN ARM ELEMENT	ELEM. BRAZO PRINC.
D	202342	1	ELEMENTO COLONNA	ELEMENT COLONNE	SÄULEELEMENT	COLUMN ELEMENT	ELEMENTO COLUMNNA
E	202341	1	ELEMENTO ROTAZIONE	ELEMENT ROTATION	DREHUNGELEMENT	ROTATION ELEMENT	ELEMENTO ROTACION



DISTRIBUTORE DANFOSS 6 ELEMENTI - H - 2° ATTIVAZIONE - 197570 (23 P)

* Distributeur DANFOSS - 6 éléments - H 2ème activation
* DANFOSS-Steuerventilblock - 6 Elemente - H - 2. Betätigung
* DANFOSS control valve block - 6 elements - H - 2nd activation
* Distribuidor DANFOSS 6 elementos - H - 2da activación

TAV. GN.02.04

matr. G107.0005

21
23 P

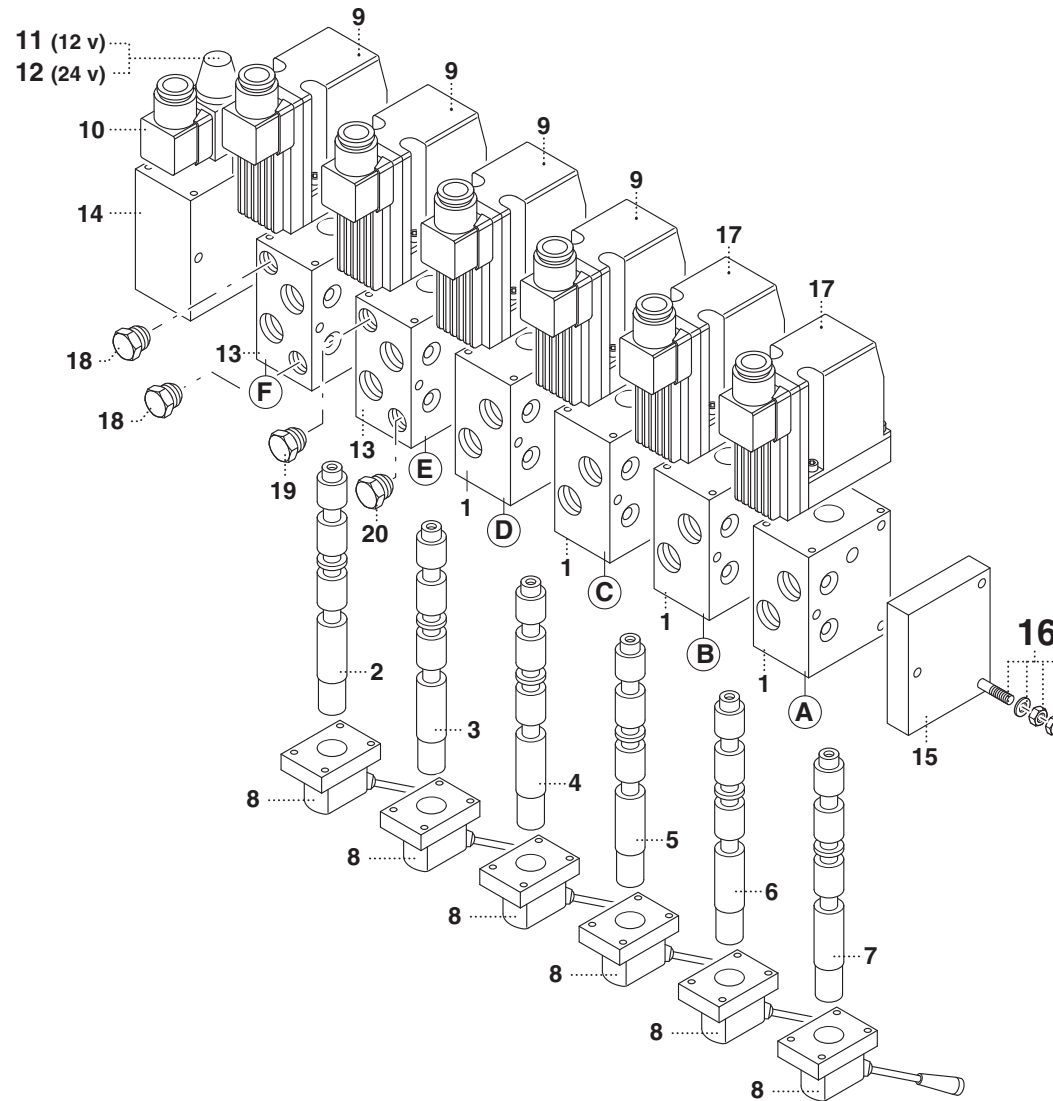

PM 23 P

matr. G107.0005

TAV. GN.02.04

POS.	N° CODICE	Q.	DESCRIZIONE	DESIGNATION	BENENNUNG	DESCRIPTION	DENOMINACIONES
1	202135	4	CORPO	CORPS	GEHÄUSE	BODY	CUERPO
2	202280	1	ASTA ROTAZIONE	TIGE ROTATION	DREHSTANGE	ROTATION ROD	VARILLA ROTACION
3	202252	1	ASTA COLONNA	TIGE COLONNE	SÄULESTANGE	COLUMN ROD	VARILLA COLUMNNA
4	202221	1	ASTA BRACCIO PRINCIPALE	TIGE BRAS PRINCIPAL	HAUPTARMSTANGE	MAIN ARM ROD	VARILLA BRAZO PRINC.
5	202149	1	ASTA SFILO BRACCI	TIGE EXTENSION BRAS	ARMAUSZIEHENSTANGE	ROD - ARM EXTENSION	VARILLA EXTEN.BRAZOS
6	202251	1	ASTA 1° ATTIVAZIONE	TIGE - 1ERE ACTIVATION	STANGE - 1.BETÄTIGUNG	ROD - 1ST ACTIVATION	VARILLA-1ERA ACTIVAC.
7	202251	1	ASTA 2° ATTIVAZIONE	TIGE - 2EME ACTIVATION	STANGE - 2.BETÄTIGUNG	ROD - 2ND ACTIVATION	VARILLA-2DA ACTIVAC.
8	202123	6	ORGANO DI MANOVRA	DISPOSITIF MOUVEMENT	SCHALTVORRICHTUNG	MOTION DEVICE	ORGANO DE MANOVRA
9	202347	4	MODULO	MODULE	MODULE	MODUL	MODULO
10	204055	1	ELETTROVALVOLA	ELECTROVANNE	ELEKTROVENTIL	ELECTROVALVE	ELECTRO-VALVULA
11	395379	1	BOBINA	BOBINE	SPULE	COIL	BOBINA
12	395380	1	BOBINA	BOBINE	SPULE	COIL	BOBINA
13	202158	2	CORPO	CORPS	GEHÄUSE	BODY	CUERPO
14	208179	1	FIANCATA	COTE	SEITENWAND	SIDE PANEL	LADO
15	202233	1	FIANCATA	COTE	SEITENWAND	SIDE PANEL	LADO
16	202138	1	KIT TIRANTE	KIT TIRANT	ZUGSTANGESATZ	TIE ROD KIT	KIT TIRANTE
17	202219	2	MODULO	MODULE	MODULE	MODUL	MODULO
18	202105	2	VALVOLA	SOUPAPE	VENTIL	VALVE	VALVULA
19	202255	1	VALVOLA	SOUPAPE	VENTIL	VALVE	VALVULA
20	202274	1	VALVOLA	SOUPAPE	VENTIL	VALVE	VALVULA
A	202348	1	ELEMENTO 2° ATTIVAZIONE	ELEMENT 2E ACTIVATION	2.BETÄTIGUNSELEMENT	2ND ACTIVAT. ELEMENT	ELEMENTO 2A ACTIVAC.
B	202348	1	ELEMENTO 1° ATTIVAZIONE	ELEMENT 1E ACTIVATION	1.BETÄTIGUNSELEMENT	1ST ACTIVAT. ELEMENT	ELEMENTO 1A ACTIVAC.
C	202344	1	ELEMENTO SFILO BRACCI	ELEMENT EXTENS. BRAS	ARMAUSZIEHENELEMENT	ARM EXTENSION ELEMENT	ELEMENT EXT. BRAZOS
D	202343	1	ELEMENTO BRACCIO PRINCIPALE	ELEMENT BRAS PRINCIPAL	HAUPTARMELEMENT	MAIN ARM ELEMENT	ELEM. BRAZO PRINC.
E	202342	1	ELEMENTO COLONNA	ELEMENT COLONNE	SÄULEELEMENT	COLUMN ELEMENT	ELEMENTO COLUMNNA
F	202341	1	ELEMENTO ROTAZIONE	ELEMENT ROTATION	DREHUNGELEMENT	ROTATION ELEMENT	ELEMENTO ROTACION



DISTRIBUTORE DANFOSS 6 ELEMENTI H - PROLUNGA ARTICOLATA - 197572 (23 P)

* Distributeur DANFOSS - 6 éléments H - rallonge articulée
* DANFOSS-Steuerventilblock - 6 Elemente H - Gelenkverlängerung
* DANFOSS control valve block - 6 elements H - jib
* Distribuidor DANFOSS 6 elementos H - extensión articulada

TAV. GN.02.05

matr. G107.0005

21
23 P

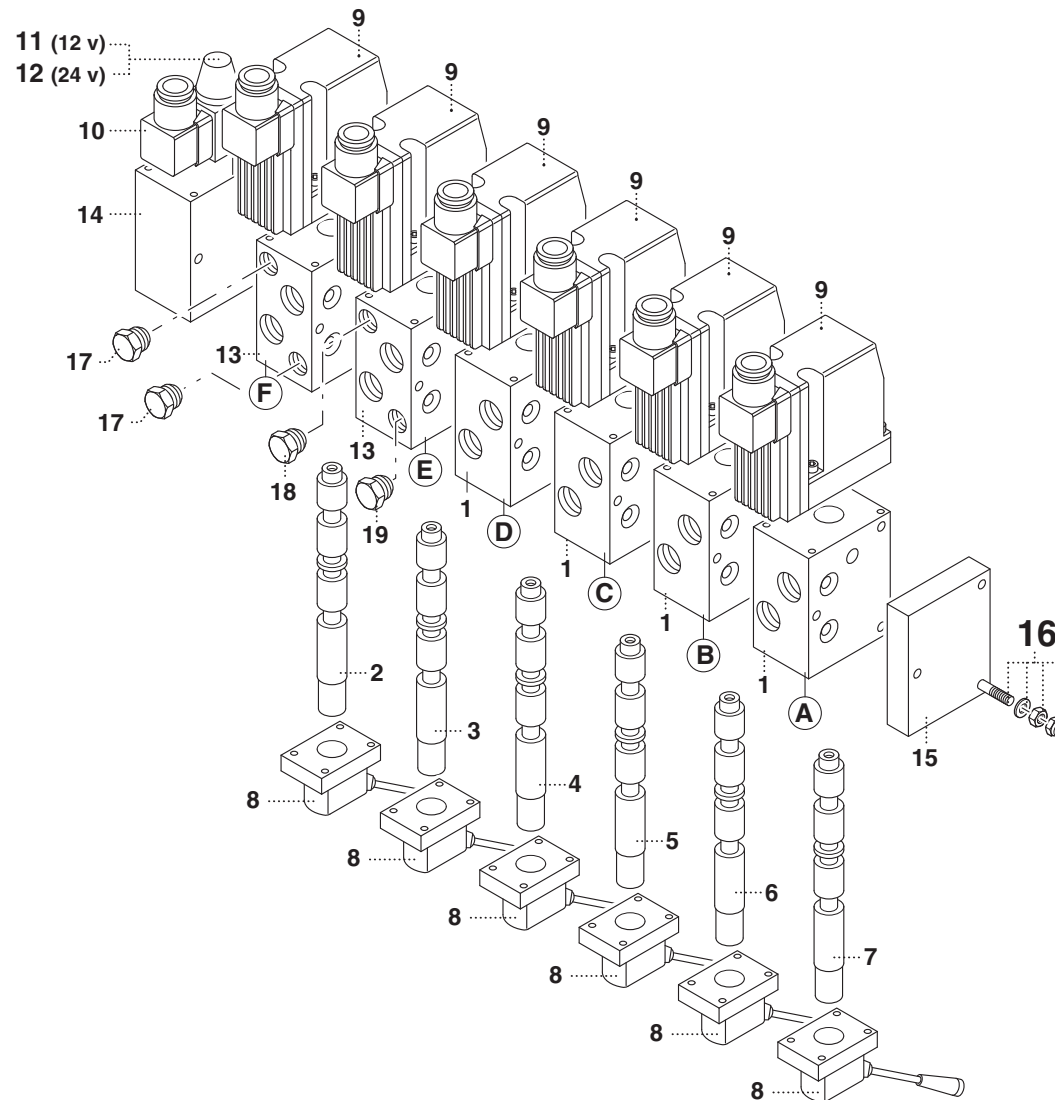

PM 23 P

matr. G107.0005

TAV. GN.02.05

POS.	N° CODICE	Q.	DESCRIZIONE	DESIGNATION	BENENNUNG	DESCRIPTION	DENOMINACIONES
1	202135	4	CORPO	CORPS	GEHÄUSE	BODY	CUERPO
2	202280	1	ASTA ROTAZIONE	TIGE ROTATION	DREHSTANGE	ROTATION ROD	VARILLA ROTACION
3	202252	1	ASTA COLONNA	TIGE COLONNE	SÄULESTANGE	COLUMN ROD	VARILLA COLUMNNA
4	202221	1	ASTA BRACCIO PRINCIPALE	TIGE BRAS PRINCIPAL	HAUPTARMSTANGE	MAIN ARM ROD	VARILLA BRAZO PRINC.
5	202149	1	ASTA SFILO BRACCI	TIGE EXTENSION BRAS	ARMAUSZIEHENSTANGE	ROD - ARM EXTENSION	VARILLA EXTEN.BRAZOS
6	202159	1	ASTA SNODO PROLUNGA ARTIC.	TIGE ARTICUL. RALL. ARTIC.	GELENKVER. GELENKSTANGE	JIB ARTICULATION ROD	VARILLA ARTICUL. EXT. AR.
7	202130	1	ASTA SFILO PROLUNGA ARTIC.	TIGE EXTEN. RALL. ARTIC.	GELENKVER. AUSZIEHENSTANGE	JIB EXTENSION ROD	VARILLA EXTENSION-EXT. AR.
8	202123	6	ORGANO DI MANOVRA	DISPOSITIF MOUVEMENT	SCHALTVORRICHTUNG	MOTION DEVICE	ORGANO DE MANOVRA
9	202347	6	MODULO	MODULE	MODULE	MODUL	MODULO
10	204055	1	ELETTROVALVOLA	ELECTROVANNE	ELEKTROVENTIL	ELECTROVALVE	ELECTRO-VALVULA
11	395379	1	BOBINA	BOBINE	SPULE	COIL	BOBINA
12	395380	1	BOBINA	BOBINE	SPULE	COIL	BOBINA
13	202158	2	CORPO	CORPS	GEHÄUSE	BODY	CUERPO
14	208179	1	FIANCATA	COTE	SEITENWAND	SIDE PANEL	LADO
15	202233	1	FIANCATA	COTE	SEITENWAND	SIDE PANEL	LADO
16	202138	1	KIT TIRANTE	KIT TIRANT	ZUGSTANGESATZ	TIE ROD KIT	KIT TIRANTE
17	202105	2	VALVOLA	SOUPAPE	VENTIL	VALVE	VALVULA
18	202255	1	VALVOLA	SOUPAPE	VENTIL	VALVE	VALVULA
19	202274	1	VALVOLA	SOUPAPE	VENTIL	VALVE	VALVULA
A	202345	1	ELEM. SFILO PROLUNGA ARTIC.	ELEM. EXTEN. RALL. ARTIC.	GELENKVER. AUSZIEHENELEM.	JIB EXTENSION ELEM.	ELEM. EXTENSION-EXT. AR.
B	202346	1	ELEM. SNODO PROLUNGA ARTIC.	ELEM. ARTICUL. RALL. ARTIC.	GELENKVER. GELENKELEM.	JIB ARTICULATION ELEM.	ELEM. ARTICUL. EXT. AR.
C	202344	1	ELEMENTO SFILO BRACCI	ELEMENT EXTENS. BRAS	ARMAUSZIEHENELEMENT	ARM EXTENSION ELEMENT	ELEMENT EXT. BRAZOS
D	202343	1	ELEMENTO BRACCIO PRINCIPALE	ELEMENT BRAS PRINCIPAL	HAUPTARMELEMENT	MAIN ARM ELEMENT	ELEM. BRAZO PRINC.
E	202342	1	ELEMENTO COLONNA	ELEMENT COLONNE	SÄULEELEMENT	COLUMN ELEMENT	ELEMENTO COLUMNNA
F	202341	1	ELEMENTO ROTAZIONE	ELEMENT ROTATION	DREHUNGELEMENT	ROTATION ELEMENT	ELEMENTO ROTACION



DISTRIBUTORE DANFOSS 7 ELEMENTI H - PROLUNGA ARTICOLATA - ARGANO - 197573 (23 P)

* Distributeur DANFOSS - 7 éléments H - rallonge articulée - treuil
* DANFOSS-Steuerventilblock - 7 Elemente H - Gelenkverlängerung - Winde
* DANFOSS control valve block - 7 elements H - jib - winch
* Distribuidor DANFOSS 6 elementos H - extensión articulada - cabrestante

TAV. GN.02.06

matr. G107.0005

21
23 P

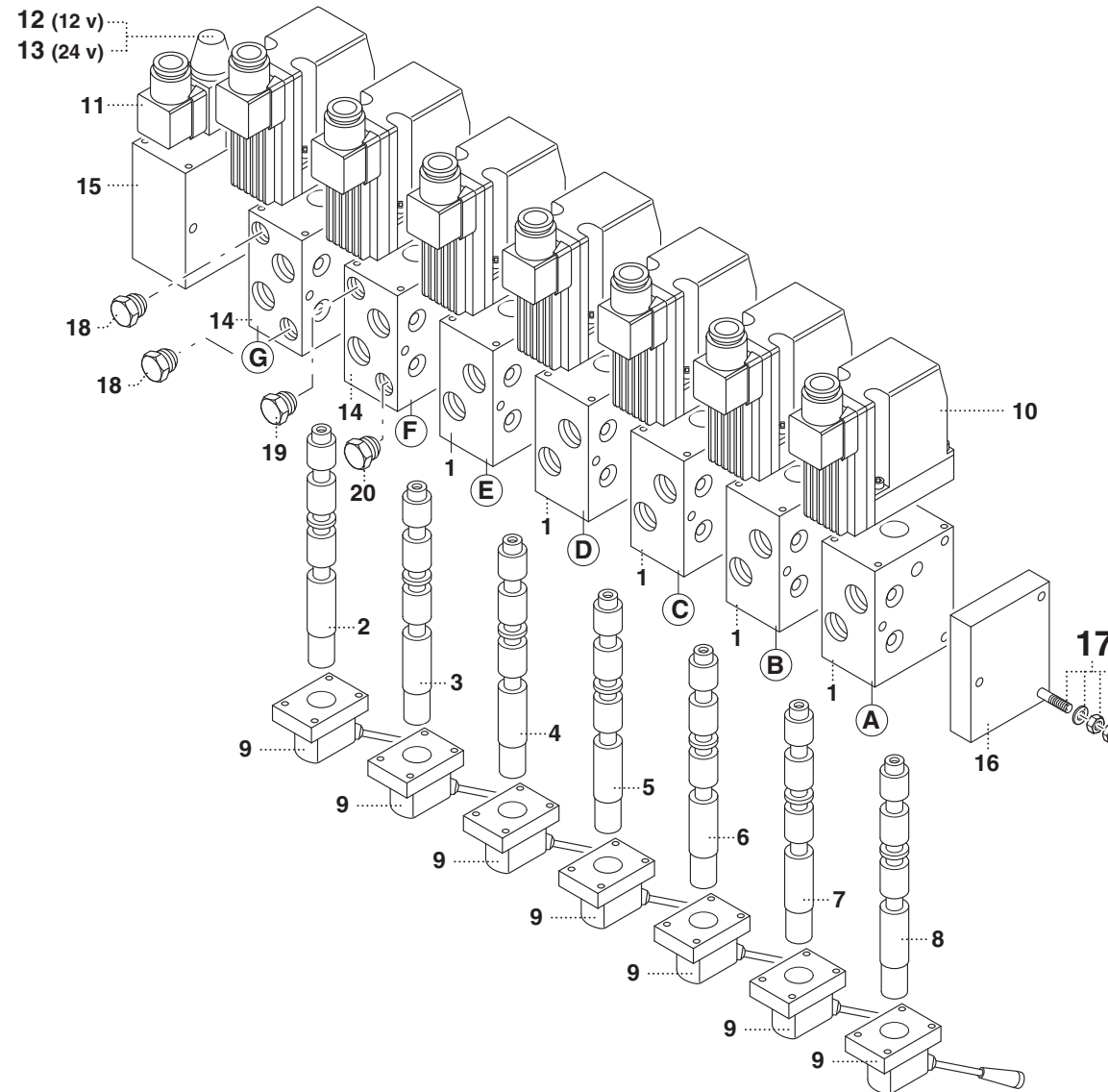

PM 23 P

matr. G107.0005

TAV. GN.02.06

POS.	N° CODICE	Q.	DESCRIZIONE	DESIGNATION	BENENNUNG	DESCRIPTION	DENOMINACIONES
1	202135	5	CORPO	CORPS	GEHÄUSE	BODY	CUERPO
2	202280	1	ASTA ROTAZIONE	TIGE ROTATION	DREHSTANGE	ROTATION ROD	VARILLA ROTACION
3	202252	1	ASTA COLONNA	TIGE COLONNE	SÄULESTANGE	COLUMN ROD	VARILLA COLUMNNA
4	202251	1	ASTA BRACCIO PRINCIPALE	TIGE BRAS PRINCIPAL	HAUPTARMSTANGE	MAIN ARM ROD	VARILLA BRAZO PRINC.
5	202149	1	ASTA SFILO BRACCI	TIGE EXTENSION BRAS	ARMAUSZIEHENSTANGE	ROD - ARM EXTENSION	VARILLA EXTEN.BRAZOS
6	202159	1	ASTA SNODO PROLUNGA ARTIC.	TIGE ARTICUL. RALL. ARTIC.	GELLENKVER. GELENKSTANGE	JIB ARTICULATION ROD	VARILLA ARTICUL. EXT. AR.
7	202130	1	ASTA SFILO PROLUNGA ARTIC.	TIGE EXTEN. RALL. ARTIC.	GELLENKVER. AUSZIEHENSTANGE	JIB EXTENSION ROD	VARILLA EXTENSION-EXT. AR.
8	202130	1	ASTA ARGANO	TIGE TREUIL	WINDESTANGE	WINCH ROD	VARILLA CABRESANTE
9	202123	7	ORGANO DI MANOVRA	DISPOSITIF MOUVEMENT	SCHALTVORRICHTUNG	MOTION DEVICE	ORGANO DE MANOVRA
10	202347	7	MODULO	MODULE	MODULE	MODUL	MODULO
11	204055	1	ELETTROVALVOLA	ELECTROVANNE	ELEKTROVENTIL	ELECTROVALVE	ELECTRO-VALVULA
12	395379	1	BOBINA	BOBINE	SPULE	COIL	BOBINA
13	395380	1	BOBINA	BOBINE	SPULE	COIL	BOBINA
14	202158	2	CORPO	CORPS	GEHÄUSE	BODY	CUERPO
15	202179	1	FIANCATA	COTE	SEITENWAND	SIDE PANEL	LADO
16	202233	1	FIANCATA	COTE	SEITENWAND	SIDE PANEL	LADO
17	202139	1	KIT TIRANTE	KIT TIRANT	ZUGSTANGESATZ	TIE ROD KIT	KIT TIRANTE
18	202105	2	VALVOLA	SOUPAPE	VENTIL	VALVE	VALVULA
19	202255	1	VALVOLA	SOUPAPE	VENTIL	VALVE	VALVULA
20	202274	1	VALVOLA	SOUPAPE	VENTIL	VALVE	VALVULA
A	202345	1	ELEMENTO ARGANO	ELEMENT TREUIL	WINDEELEMENT	WINCH ELEMENT	ELEM. CABRESTANTE
B	202345	1	ELEM. SFILO PROLUNGA ARTIC.	ELEM. EXTEN. RALL. ARTIC.	GELLENKVER. AUSZIEHENELEM.	JIB EXTENSION ELEM.	ELEM. EXTENSION-EXT. AR.
C	202346	1	ELEM. SNODO PROLUNGA ARTIC.	ELEM. ARTICUL. RALL. ARTIC.	GELLENKVER. GELENKELEM.	JIB ARTICULATION ELEM.	ELEM. ARTICUL. EXT. AR.
D	202344	1	ELEMENTO SFILO BRACCI	ELEMENT EXTENS. BRAS	ARMAUSZIEHENELEMENT	ARM EXTENSION ELEMENT	ELEMENT EXT. BRAZOS
E	202343	1	ELEMENTO BRACCIO PRINCIPALE	ELEMENT BRAS PRINCIPAL	HAUPTARMELEMENT	MAIN ARM ELEMENT	ELEM. BRAZO PRINC.
F	202342	1	ELEMENTO COLONNA	ELEMENT COLONNE	SÄULEELEMENT	COLUMN ELEMENT	ELEMENTO COLUMNNA



DISTRIBUTORE DANFOSS 7 ELEMENTI H - PROLUNGA ARTICOLATA - ARGANO - 197573 (23 P)

* Distributeur DANFOSS - 7 éléments H - rallonge articulée - treuil
* DANFOSS-Steuerventilblock - 7 Elemente H - Gelenkverlängerung - Winde
* DANFOSS control valve block - 7 elements H - jib - winch
* Distribuidor DANFOSS 6 elementos H - extensión articulada - cabrestante

TAV. GN.02.06

matr. G107.0005

21
23 P

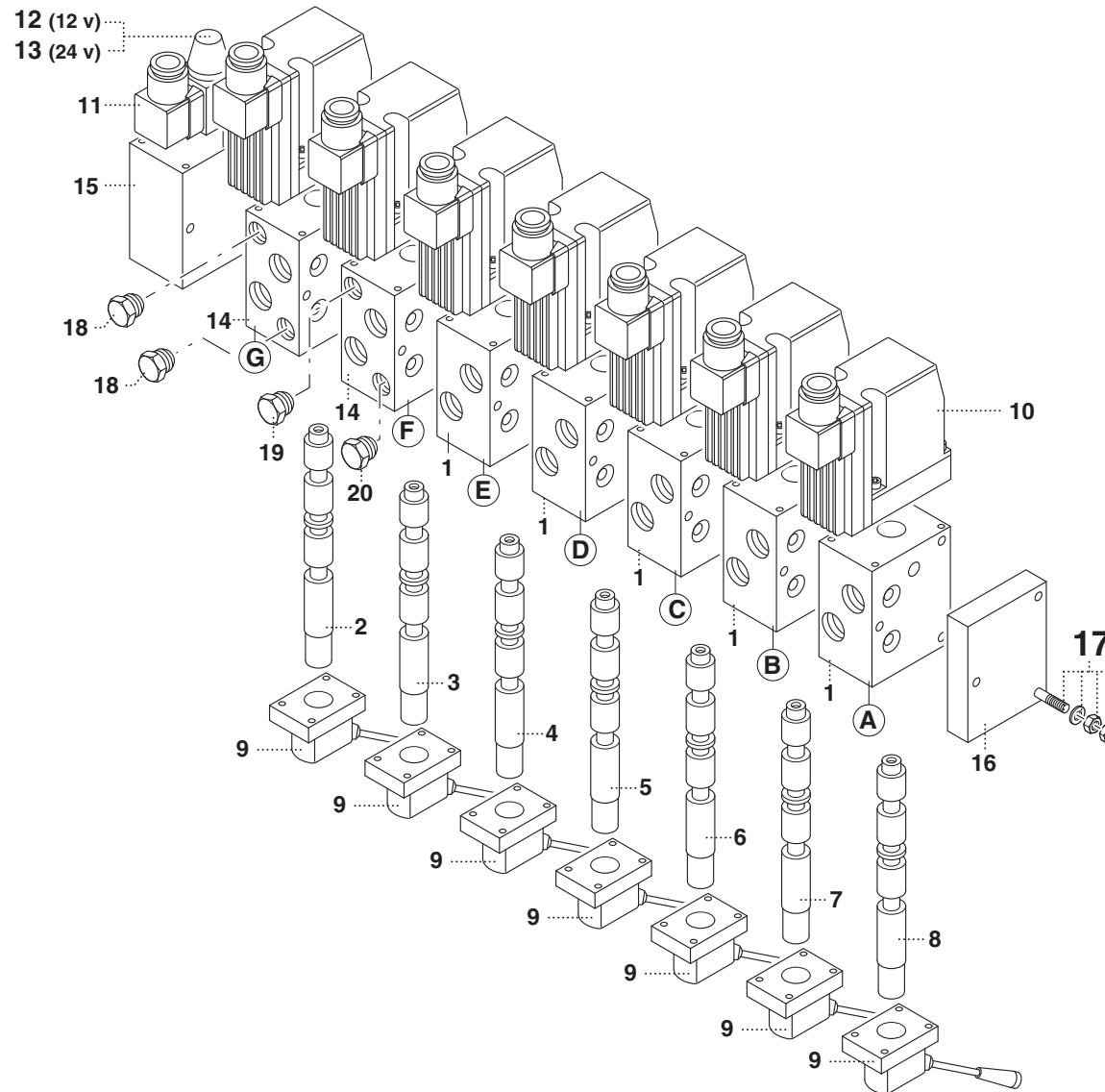

PM 23 P

matr. G107.0005

TAV. GN.02.07

POS.	N° CODICE	Q.	DESCRIZIONE	DESIGNATION	BENENNUNG	DESCRIPTION	DENOMINACIONES
1	202135	2	CORPO	CORPS	GEHÄUSE	BODY	CUERPO
2	202280	1	ASTA ROTAZIONE	TIGE ROTATION	DREHSTANGE	ROTATION ROD	VARILLA ROTACION
3	202252	1	ASTA COLONNA	TIGE COLONNE	SÄULESTANGE	COLUMN ROD	VARILLA COLUMNNA
4	202221	1	ASTA BRACCIO PRINCIPALE	TIGE BRAS PRINCIPAL	HAUPTARMSTANGE	MAIN ARM ROD	VARILLA BRAZO PRINC.
5	202149	1	ASTA SFILO BRACCI	TIGE EXTENSION BRAS	ARMAUSZIEHENSTANGE	ROD - ARM EXTENSION	VARILLA EXTEN.BRAZOS
6	202123	4	ORGANO DI MANOVRA	DISPOSITIF MOUVEMENT	SCHALTVORRICHTUNG	MOTION DEVICE	ORGANO DE MANOVRA
7	202211	4	MODULO	MODULE	MODULE	MODUL	MODULO
8	204055	1	ELETTROVALVOLA	ELECTROVANNE	ELEKTROVENTIL	ELECTROVALVE	ELECTRO-VALVULA
9	395379	1	BOBINA	BOBINE	SPULE	COIL	BOBINA
10	395380	1	BOBINA	BOBINE	SPULE	COIL	BOBINA
11	202158	2	CORPO	CORPS	GEHÄUSE	BODY	CUERPO
12	202179	1	FIANCATA	COTE	SEITENWAND	SIDE PANEL	LADO
13	202233	1	FIANCATA	COTE	SEITENWAND	SIDE PANEL	LADO
14	202168	1	KIT TIRANTE	KIT TIRANT	ZUGSTANGESATZ	TIE ROD KIT	KIT TIRANTE
15	202105	2	VALVOLA	SOUPAPE	VENTIL	VALVE	VALVULA
16	202255	1	VALVOLA	SOUPAPE	VENTIL	VALVE	VALVULA
17	202274	1	VALVOLA	SOUPAPE	VENTIL	VALVE	VALVULA
A	202355	1	ELEMENTO SFILO BRACCI	ELEMENT EXTENS. BRAS	ARMAUSZIEHENELEMENT	ARM EXTENSION ELEMENT	ELEMENT EXT. BRAZOS
B	202354	1	ELEMENTO BRACCIO PRINCIPALE	ELEMENT BRAS PRINCIPAL	HAUPTARMELEMENT	MAIN ARM ELEMENT	ELEM. BRAZO PRINC.
C	202353	1	ELEMENTO COLONNA	ELEMENT COLONNE	SÄULEELEMENT	COLUMN ELEMENT	ELEMENTO COLUMNNA
D	202352	1	ELEMENTO ROTAZIONE	ELEMENT ROTATION	DREHUNGELEMENT	ROTATION ELEMENT	ELEMENTO ROTACION



DISTRIBUTORE DANFOSS 5 ELEMENTI - A - 1° ATTIVAZIONE - 197551 (23 P)

* Distributeur DANFOSS - 5 éléments - A 1ère activation
* DANFOSS-Steuerventilblock - 5 Elemente - A - 1. Betätigung
* DANFOSS control valve block - 5 elements - A - 1st activation
* Distribuidor DANFOSS 5 elementos - A - 1era activación

TAV. GN.02.08

matr. G107.0005

21
23 P

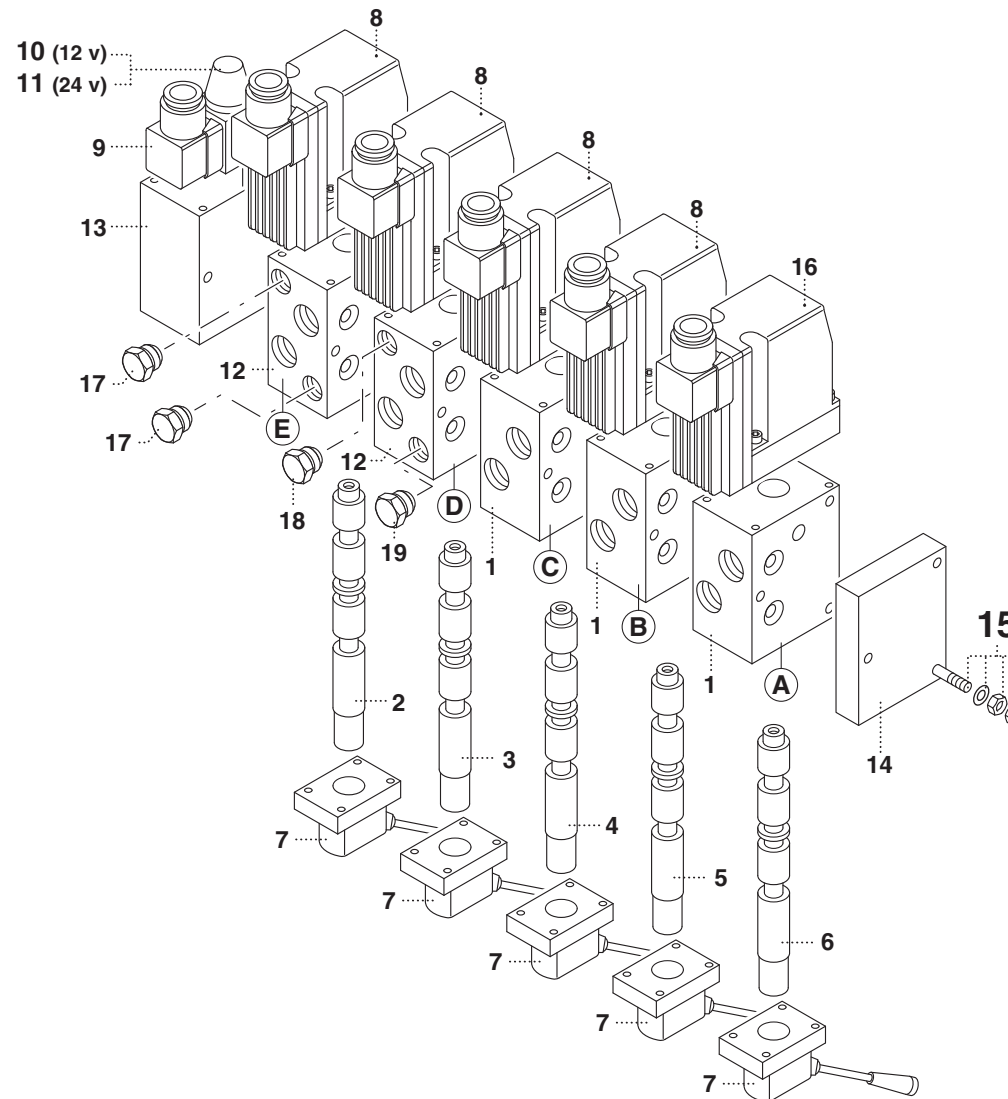

PM 23 P

matr. G107.0005

TAV. GN.02.08

POS.	N° CODICE	Q.	DESCRIZIONE	DESIGNATION	BENENNUNG	DESCRIPTION	DENOMINACIONES
1	202135	3	CORPO	CORPS	GEHÄUSE	BODY	CUERPO
2	202280	1	ASTA ROTAZIONE	TIGE ROTATION	DREHSTANGE	ROTATION ROD	VARILLA ROTACION
3	202252	1	ASTA COLONNA	TIGE COLONNE	SÄULESTANGE	COLUMN ROD	VARILLA COLUMNNA
4	202221	1	ASTA BRACCIO PRINCIPALE	TIGE BRAS PRINCIPAL	HAUPTARMSTANGE	MAIN ARM ROD	VARILLA BRAZO PRINC.
5	202149	1	ASTA SFILO BRACCI	TIGE EXTENSION BRAS	ARMAUSZIEHENSTANGE	ROD - ARM EXTENSION	VARILLA EXTEN.BRAZOS
6	202251	1	ASTA 1° ATTIVAZIONE	TIGE - 1ERE ACTIVATION	STANGE - 1.BETÄTIGUNG	ROD - 1ST ACTIVATION	VARILLA-1ERA ACTIVAC.
7	202123	5	ORGANO DI MANOVRA	DISPOSITIF MOUVEMENT	SCHALTVORRICHTUNG	MOTION DEVICE	ORGANO DE MANOVRA
8	202211	4	MODULO	MODULE	MODULE	MODUL	MODULO
9	204055	1	ELETTROVALVOLA	ELECTROVANNE	ELEKTROVENTIL	ELECTROVALVE	ELECTRO-VALVULA
10	395379	1	BOBINA	BOBINE	SPULE	COIL	BOBINA
11	395380	1	BOBINA	BOBINE	SPULE	COIL	BOBINA
12	202158	2	CORPO	CORPS	GEHÄUSE	BODY	CUERPO
13	202179	1	FIANCATA	COTE	SEITENWAND	SIDE PANEL	LADO
14	202233	1	FIANCATA	COTE	SEITENWAND	SIDE PANEL	LADO
15	202162	1	KIT TIRANTE	KIT TIRANT	ZUGSTANGESATZ	TIE ROD KIT	KIT TIRANTE
16	202185	1	MODULO	MODULE	MODULE	MODUL	MODULO
17	202105	2	VALVOLA	SOUPAPE	VENTIL	VALVE	VALVULA
18	202255	1	VALVOLA	SOUPAPE	VENTIL	VALVE	VALVULA
19	202274	1	VALVOLA	SOUPAPE	VENTIL	VALVE	VALVULA
A	202358	1	ELEMENTO 1° ATTIVAZIONE	ELEMENT 1E ACTIVATION	1.BETÄTIGUNSELEMENT	1ST ACTIVAT. ELEMENT	ELEMENTO 1A ACTIVAC.
B	202355	1	ELEMENTO SFILO BRACCI	ELEMENT EXTENS. BRAS	ARMAUSZIEHENELEMENT	ARM EXTENSION ELEMENT	ELEMENT EXT. BRAZOS
C	202354	1	ELEMENTO BRACCIO PRINCIPALE	ELEMENT BRAS PRINCIPAL	HAUPTARMELEMENT	MAIN ARM ELEMENT	ELEM. BRAZO PRINC.
D	202353	1	ELEMENTO COLONNA	ELEMENT COLONNE	SÄULEELEMENT	COLUMN ELEMENT	ELEMENTO COLUMNNA
E	202352	1	ELEMENTO ROTAZIONE	ELEMENT ROTATION	DREHUNGELEMENT	ROTATION ELEMENT	ELEMENTO ROTACION



DISTRIBUTORE DANFOSS 5 ELEMENTI A - ARGANO - 197552 (23 P)

- * Distributeur DANFOSS - 5 éléments A - treuil
- * DANFOSS-Steuerventilblock - 5 Elemente A - Winde
- * DANFOSS control valve block - 5 elements A - winch
- * Distribuidor DANFOSS 5 elementos A - cabrestante

TAV. GN.02.09

matr. G107.0005

21
23 P

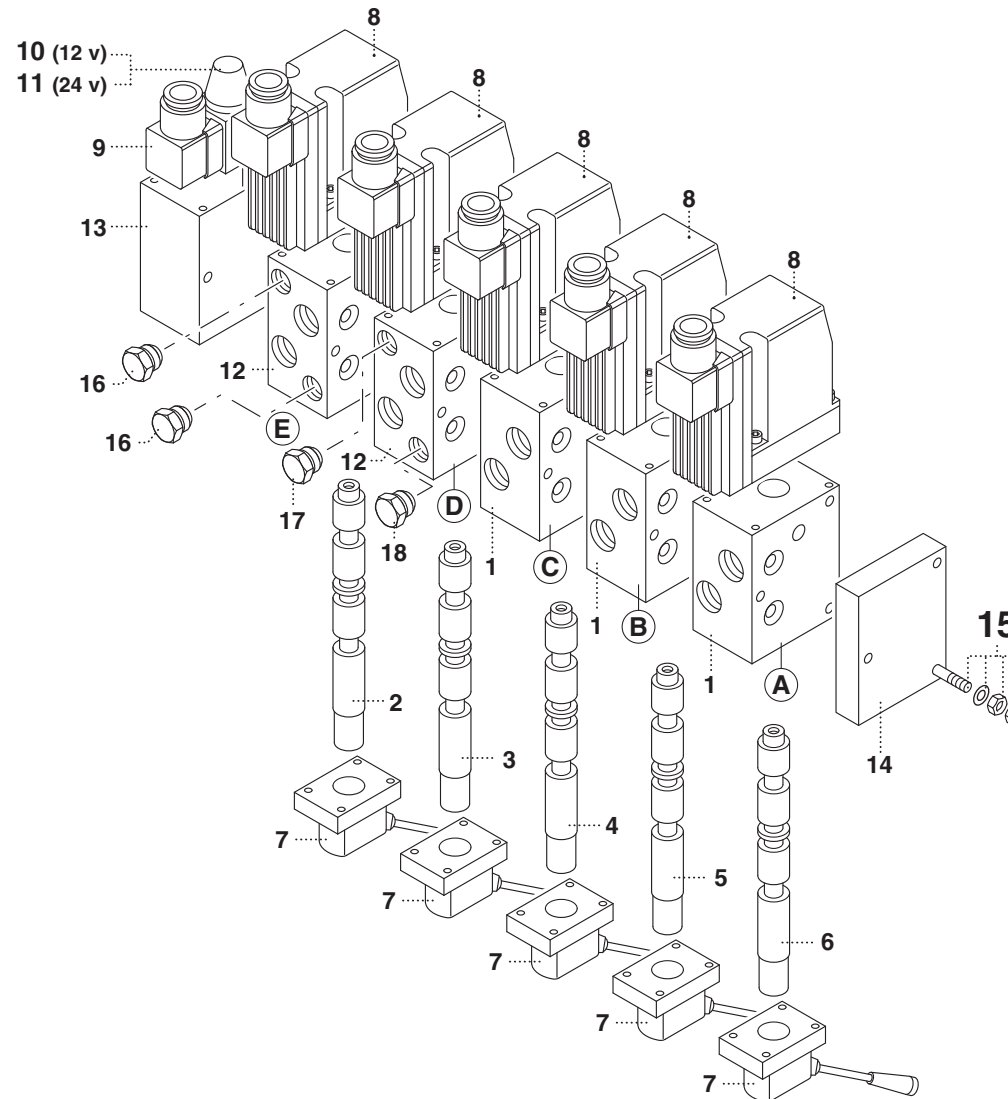

PM 23 P

matr. G107.0005

TAV. GN.02.09

POS.	N° CODICE	Q.	DESCRIZIONE	DESIGNATION	BENENNUNG	DESCRIPTION	DENOMINACIONES
1	202135	3	CORPO	CORPS	GEHÄUSE	BODY	CUERPO
2	202280	1	ASTA ROTAZIONE	TIGE ROTATION	DREHSTANGE	ROTATION ROD	VARILLA ROTACION
3	202252	1	ASTA COLONNA	TIGE COLONNE	SÄULESTANGE	COLUMN ROD	VARILLA COLUMNNA
4	202221	1	ASTA BRACCIO PRINCIPALE	TIGE BRAS PRINCIPAL	HAUPTARMSTANGE	MAIN ARM ROD	VARILLA BRAZO PRINC.
5	202149	1	ASTA SFILO BRACCI	TIGE EXTENSION BRAS	ARMAUSZIEHENSTANGE	ROD - ARM EXTENSION	VARILLA EXTEN.BRAZOS
6	202130	1	ASTA ARGANO	TIGE TREUIL	WINDESTANGE	WINCH ROD	VARILLA CABRESANTE
7	202123	5	LEVA	LEVIER	HEBEL	LEVER	PALANCA
8	202211	5	MODULO	MODULE	MODULE	MODUL	MODULO
9	204055	1	ELETTROVALVOLA	ELECTROVANNE	ELEKTROVENTIL	ELECTROVALVE	ELECTRO-VALVULA
10	395379	1	BOBINA	BOBINE	SPULE	COIL	BOBINA
11	395380	1	BOBINA	BOBINE	SPULE	COIL	BOBINA
12	202158	2	CORPO	CORPS	GEHÄUSE	BODY	CUERPO
13	202179	1	FIANCATA	COTE	SEITENWAND	SIDE PANEL	LADO
14	202233	1	FIANCATA	COTE	SEITENWAND	SIDE PANEL	LADO
15	202162	1	KIT TIRANTE	KIT TIRANT	ZUGSTANGESATZ	TIE ROD KIT	KIT TIRANTE
16	202105	2	VALVOLA	SOUPAPE	VENTIL	VALVE	VALVULA
17	202255	1	VALVOLA	SOUPAPE	VENTIL	VALVE	VALVULA
18	202274	1	VALVOLA	SOUPAPE	VENTIL	VALVE	VALVULA
A	202356	1	ELEMENTO ARGANO	ELEMENT TREUIL	WINDEELEMENT	WINCH ELEMENT	ELEM. CABRESTANTE
B	202355	1	ELEMENTO SFILO BRACCI	ELEMENT EXTENS. BRAS	ARMAUSZIEHENELEMENT	ARM EXTENSION ELEMENT	ELEMENT EXT. BRAZOS
C	202354	1	ELEMENTO BRACCIO PRINCIPALE	ELEMENT BRAS PRINCIPAL	HAUPTARMELEMENT	MAIN ARM ELEMENT	ELEM. BRAZO PRINC.
D	202353	1	ELEMENTO COLONNA	ELEMENT COLONNE	SÄULEELEMENT	COLUMN ELEMENT	ELEMENTO COLUMNNA
E	202352	1	ELEMENTO ROTAZIONE	ELEMENT ROTATION	DREHUNGELEMENT	ROTATION ELEMENT	ELEMENTO ROTACION



DISTRIBUTORE DANFOSS 6 ELEMENTI - A - 2° ATTIVAZIONE - 197553 (23 P)

* Distributeur DANFOSS - 6 éléments - A 2ème activation
* DANFOSS-Steuerventilblock - 6 Elemente - A - 2. Betätigung
* DANFOSS control valve block - 6 elements - A - 2nd activation
* Distribuidor DANFOSS 6 elementos - A - 2da activación

TAV. GN.02.10

matr. G107.0005

21
23 P

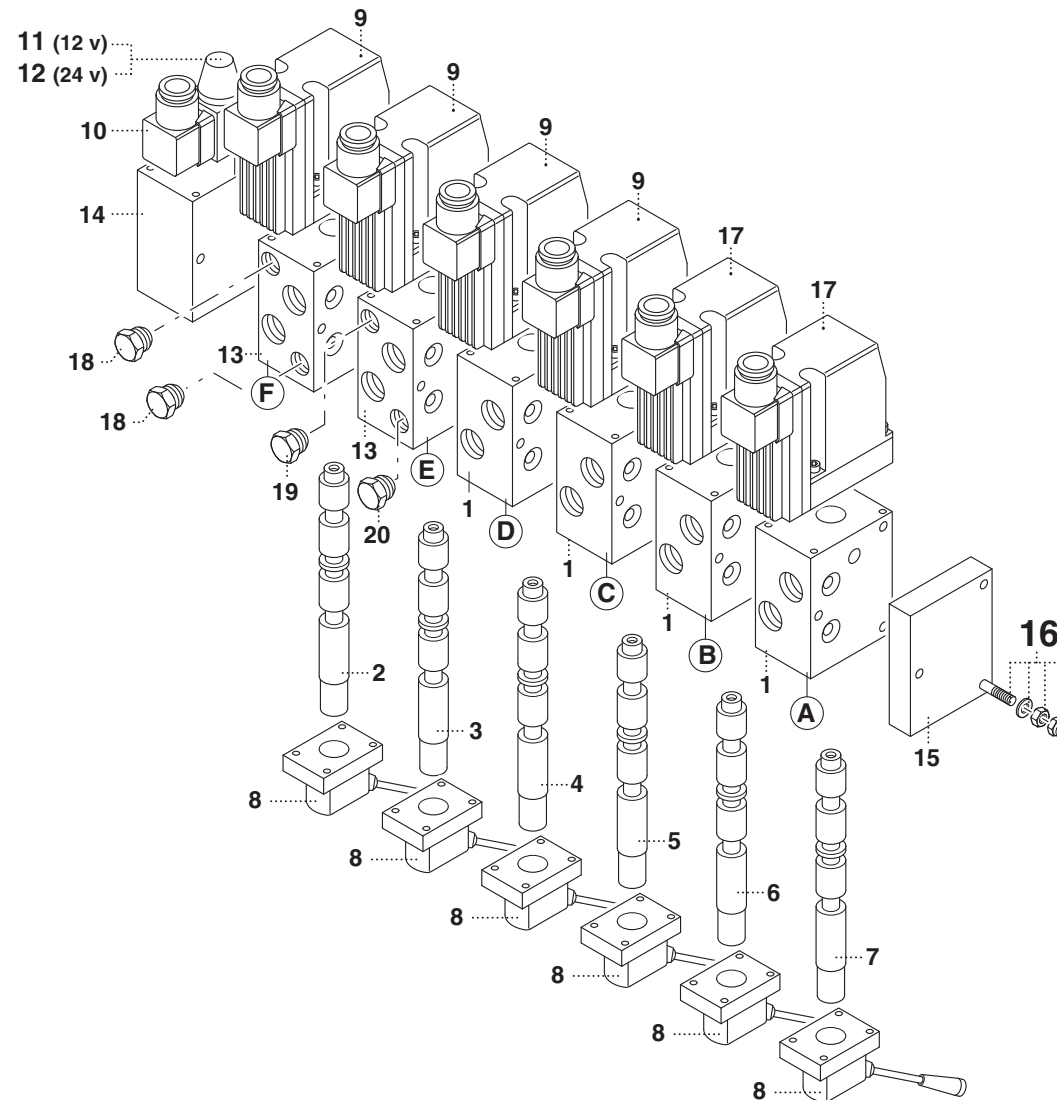

PM 23 P

matr. G107.0005

TAV. GN.02.10

POS.	N° CODICE	Q.	DESCRIZIONE	DESIGNATION	BENENNUNG	DESCRIPTION	DENOMINACIONES
1	202135	4	CORPO	CORPS	GEHÄUSE	BODY	CUERPO
2	202280	1	ASTA ROTAZIONE	TIGE ROTATION	DREHSTANGE	ROTATION ROD	VARILLA ROTACION
3	202252	1	ASTA COLONNA	TIGE COLONNE	SÄULESTANGE	COLUMN ROD	VARILLA COLUMNNA
4	202221	1	ASTA BRACCIO PRINCIPALE	TIGE BRAS PRINCIPAL	HAUPTARMSTANGE	MAIN ARM ROD	VARILLA BRAZO PRINC.
5	202149	1	ASTA SFILO BRACCI	TIGE EXTENSION BRAS	ARMAUSZIEHENSTANGE	ROD - ARM EXTENSION	VARILLA EXTEN.BRAZOS
6	202251	1	ASTA 1° ATTIVAZIONE	TIGE - 1ERE ACTIVATION	STANGE - 1.BETÄTIGUNG	ROD - 1ST ACTIVATION	VARILLA-1ERA ACTIVAC.
7	202251	1	ASTA 2° ATTIVAZIONE	TIGE - 2EME ACTIVATION	STANGE - 2.BETÄTIGUNG	ROD - 2ND ACTIVATION	VARILLA-2DA ACTIVAC.
8	202123	6	ORGANO DI MANOVRA	DISPOSITIF MOUVEMENT	SCHALTVORRICHTUNG	MOTION DEVICE	ORGANO DE MANOVRA
9	202211	4	MODULO	MODULE	MODULE	MODUL	MODULO
10	204055	1	ELETTROVALVOLA	ELECTROVANNE	ELEKTROVENTIL	ELECTROVALVE	ELECTRO-VALVULA
11	395379	1	BOBINA	BOBINE	SPULE	COIL	BOBINA
12	395380	1	BOBINA	BOBINE	SPULE	COIL	BOBINA
13	202158	2	CORPO	CORPS	GEHÄUSE	BODY	CUERPO
14	208179	1	FIANCATA	COTE	SEITENWAND	SIDE PANEL	LADO
15	202233	1	FIANCATA	COTE	SEITENWAND	SIDE PANEL	LADO
16	202138	1	KIT TIRANTE	KIT TIRANT	ZUGSTANGESATZ	TIE ROD KIT	KIT TIRANTE
17	202185	2	MODULO	MODULE	MODULE	MODUL	MODULO
18	202105	2	VALVOLA	SOUPAPE	VENTIL	VALVE	VALVULA
19	202255	1	VALVOLA	SOUPAPE	VENTIL	VALVE	VALVULA
20	202274	1	VALVOLA	SOUPAPE	VENTIL	VALVE	VALVULA
A	202358	1	ELEMENTO 2° ATTIVAZIONE	ELEMENT 2E ACTIVATION	2.BETÄTIGUNSELEMENT	2ND ACTIVAT. ELEMENT	ELEMENTO 2A ACTIVAC.
B	202358	1	ELEMENTO 1° ATTIVAZIONE	ELEMENT 1E ACTIVATION	1.BETÄTIGUNSELEMENT	1ST ACTIVAT. ELEMENT	ELEMENTO 1A ACTIVAC.
C	202355	1	ELEMENTO SFILO BRACCI	ELEMENT EXTENS. BRAS	ARMAUSZIEHENELEMENT	ARM EXTENSION ELEMENT	ELEMENT EXT. BRAZOS
D	202354	1	ELEMENTO BRACCIO PRINCIPALE	ELEMENT BRAS PRINCIPAL	HAUPTARMELEMENT	MAIN ARM ELEMENT	ELEM. BRAZO PRINC.
E	202353	1	ELEMENTO COLONNA	ELEMENT COLONNE	SÄULEELEMENT	COLUMN ELEMENT	ELEMENTO COLUMNNA
F	202352	1	ELEMENTO ROTAZIONE	ELEMENT ROTATION	DREHUNGELEMENT	ROTATION ELEMENT	ELEMENTO ROTACION



DISTRIBUTORE DANFOSS 6 ELEMENTI A - PROLUNGA ARTICOLATA - 197554 (23 P)

* Distributeur DANFOSS - 6 éléments A - rallonge articulée
* DANFOSS-Steuerventilblock - 6 Elemente A - Gelenkverlängerung
* DANFOSS control valve block - 6 elements A - jib
* Distribuidor DANFOSS 6 elementos A - extensión articulada

TAV. GN.02.11

matr. G107.0005

21
23 P

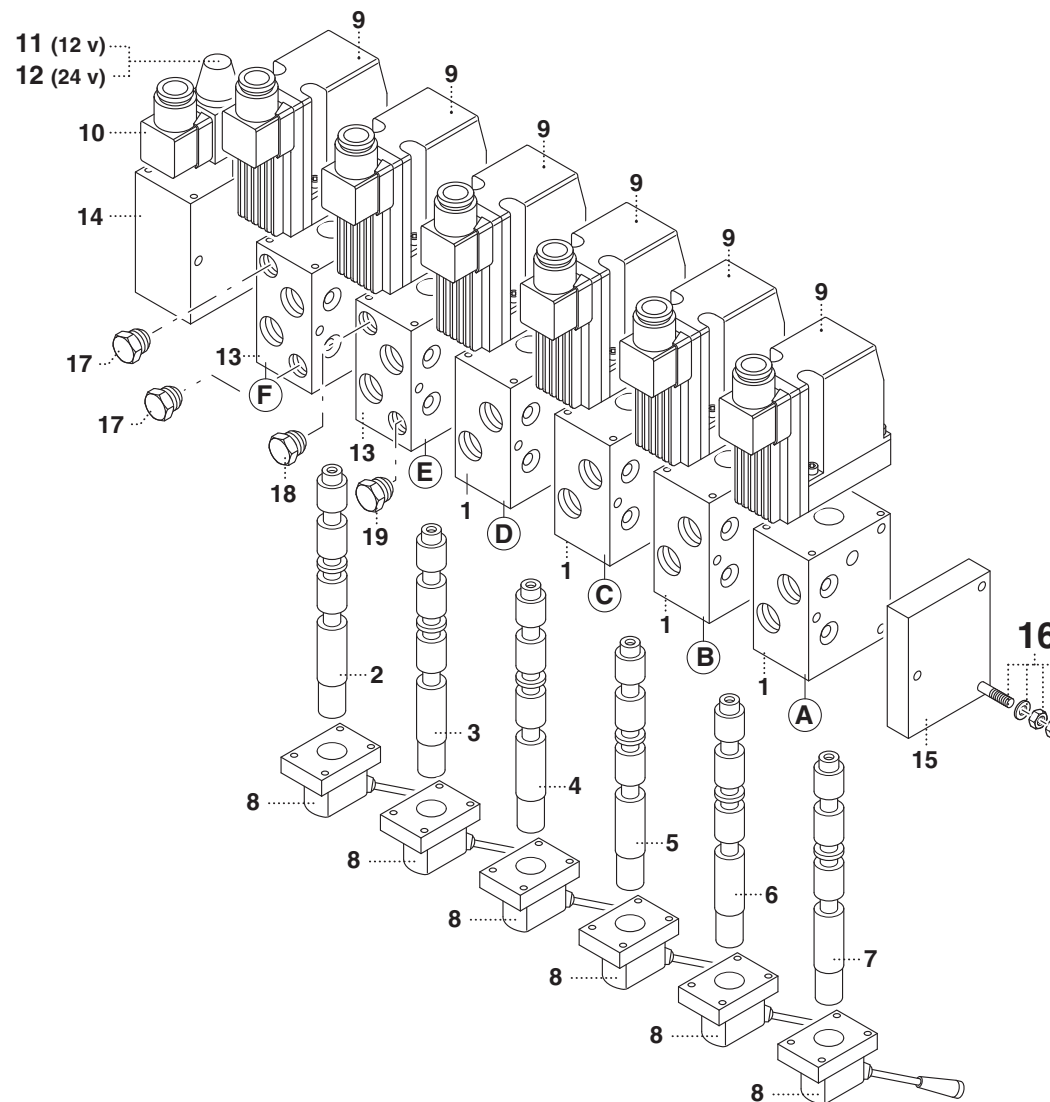

PM 23 P

matr. G107.0005

TAV. GN.02.11

POS.	N° CODICE	Q.	DESCRIZIONE	DESIGNATION	BENENNUNG	DESCRIPTION	DENOMINACIONES
1	202135	4	CORPO	CORPS	GEHÄUSE	BODY	CUERPO
2	202280	1	ASTA ROTAZIONE	TIGE ROTATION	DREHSTANGE	ROTATION ROD	VARILLA ROTACION
3	202252	1	ASTA COLONNA	TIGE COLONNE	SÄULESTANGE	COLUMN ROD	VARILLA COLUMNNA
4	202221	1	ASTA BRACCIO PRINCIPALE	TIGE BRAS PRINCIPAL	HAUPTARMSTANGE	MAIN ARM ROD	VARILLA BRAZO PRINC.
5	202149	1	ASTA SFILO BRACCI	TIGE EXTENSION BRAS	ARMAUSZIEHENSTANGE	ROD - ARM EXTENSION	VARILLA EXTEN.BRAZOS
6	202159	1	ASTA SNODO PROLUNGA ARTIC.	TIGE ARTICUL. RALL. ARTIC.	GELENKVER. GELENKSTANGE	JIB ARTICULATION ROD	VARILLA ARTICUL. EXT. AR.
7	202130	1	ASTA SFILO PROLUNGA ARTIC.	TIGE EXTEN. RALL. ARTIC.	GELENKVER. AUSZIEHENSTANGE	JIB EXTENSION ROD	VARILLA EXTENSION-EXT. AR.
8	202123	6	ORGANO DI MANOVRA	DISPOSITIF MOUVEMENT	SCHALTVORRICHTUNG	MOTION DEVICE	ORGANO DE MANOVRA
9	202211	6	MODULO	MODULE	MODULE	MODUL	MODULO
10	204055	1	ELETTROVALVOLA	ELECTROVANNE	ELEKTROVENTIL	ELECTROVALVE	ELECTRO-VALVULA
11	395379	1	BOBINA	BOBINE	SPULE	COIL	BOBINA
12	395380	1	BOBINA	BOBINE	SPULE	COIL	BOBINA
13	202158	2	CORPO	CORPS	GEHÄUSE	BODY	CUERPO
14	208179	1	FIANCATA	COTE	SEITENWAND	SIDE PANEL	LADO
15	202233	1	FIANCATA	COTE	SEITENWAND	SIDE PANEL	LADO
16	202138	1	KIT TIRANTE	KIT TIRANT	ZUGSTANGESATZ	TIE ROD KIT	KIT TIRANTE
17	202105	2	VALVOLA	SOUPAPE	VENTIL	VALVE	VALVULA
18	202255	1	VALVOLA	SOUPAPE	VENTIL	VALVE	VALVULA
19	202274	1	VALVOLA	SOUPAPE	VENTIL	VALVE	VALVULA
A	202356	1	ELEM. SFILO PROLUNGA ARTIC.	ELEM. EXTEN. RALL. ARTIC.	GELENKVER. AUSZIEHENELEM.	JIB EXTENSION ELEM.	ELEM. EXTENSION-EXT. AR.
B	202357	1	ELEM. SNODO PROLUNGA ARTIC.	ELEM. ARTICUL. RALL. ARTIC.	GELENKVER. GELENKELEM.	JIB ARTICULATION ELEM.	ELEM. ARTICUL. EXT. AR.
C	202355	1	ELEMENTO SFILO BRACCI	ELEMENT EXTENS. BRAS	ARMAUSZIEHENELEMENT	ARM EXTENSION ELEMENT	ELEMENT EXT. BRAZOS
D	202354	1	ELEMENTO BRACCIO PRINCIPALE	ELEMENT BRAS PRINCIPAL	HAUPTARMELEMENT	MAIN ARM ELEMENT	ELEM. BRAZO PRINC.
E	202353	1	ELEMENTO COLONNA	ELEMENT COLONNE	SÄULEELEMENT	COLUMN ELEMENT	ELEMENTO COLUMNNA
F	202352	1	ELEMENTO ROTAZIONE	ELEMENT ROTATION	DREHUNGELEMENT	ROTATION ELEMENT	ELEMENTO ROTACION



DISTRIBUTORE DANFOSS 7 ELEMENTI A - PROLUNGA ARTICOLATA - ARGANO - 197567 (23 P)

* Distributeur DANFOSS - 7 éléments A - rallonge articulée - treuil
* DANFOSS-Steuerventilblock - 7 Elemente A - Gelenkverlängerung - Winde
* DANFOSS control valve block - 7 elements A - jib - winch
* Distribuidor DANFOSS 6 elementos A - extensión articulada - cabrestante

TAV. GN.02.12

matr. G107.0005

21
23 P

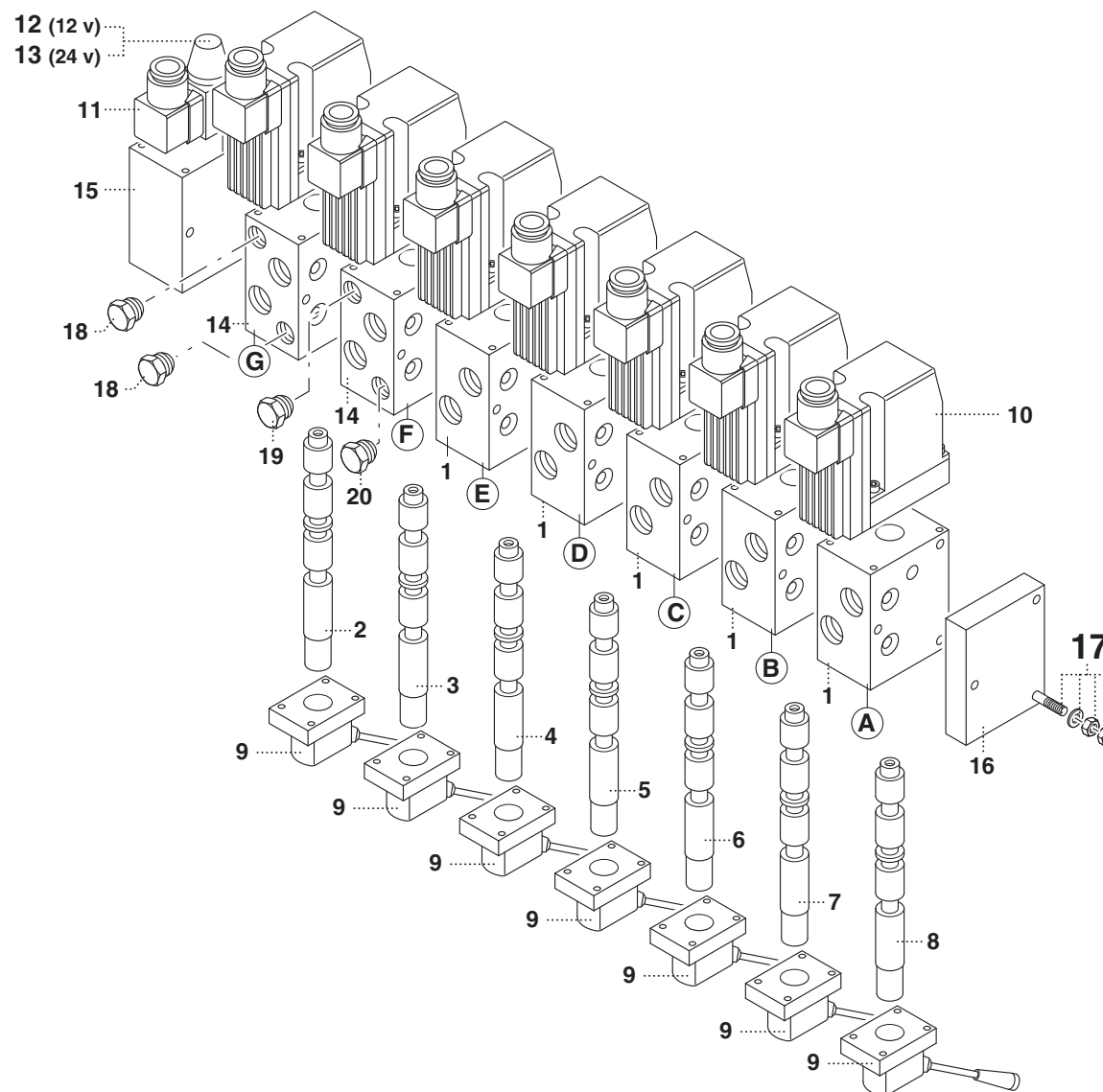

PM 23 P

matr. G107.0005

TAV. GN.02.12

POS.	N° CODICE	Q.	DESCRIZIONE	DESIGNATION	BENENNUNG	DESCRIPTION	DENOMINACIONES
1	202135	5	CORPO	CORPS	GEHÄUSE	BODY	CUERPO
2	202280	1	ASTA ROTAZIONE	TIGE ROTATION	DREHSTANGE	ROTATION ROD	VARILLA ROTACION
3	202252	1	ASTA COLONNA	TIGE COLONNE	SÄULESTANGE	COLUMN ROD	VARILLA COLUMNNA
4	202251	1	ASTA BRACCIO PRINCIPALE	TIGE BRAS PRINCIPAL	HAUPTARMSTANGE	MAIN ARM ROD	VARILLA BRAZO PRINC.
5	202149	1	ASTA SFILO BRACCI	TIGE EXTENSION BRAS	ARMAUSZIEHENSTANGE	ROD - ARM EXTENSION	VARILLA EXTEN.BRAZOS
6	202159	1	ASTA SNODO PROLUNGA ARTIC.	TIGE ARTICUL. RALL. ARTIC.	GELLENKVER. GELENKSTANGE	JIB ARTICULATION ROD	VARILLA ARTICUL. EXT. AR.
7	202130	1	ASTA SFILO PROLUNGA ARTIC.	TIGE EXTEN. RALL. ARTIC.	GELLENKVER. AUSZIEHENSTANGE	JIB EXTENSION ROD	VARILLA EXTENSION-EXT. AR.
8	202130	1	ASTA ARGANO	TIGE TREUIL	WINDESTANGE	WINCH ROD	VARILLA CABRESANTE
9	202123	7	ORGANO DI MANOVRA	DISPOSITIF MOUVEMENT	SCHALTVORRICHTUNG	MOTION DEVICE	ORGANO DE MANOVRA
10	202211	7	MODULO	MODULE	MODULE	MODUL	MODULO
11	204055	1	ELETTROVALVOLA	ELECTROVANNE	ELEKTROVENTIL	ELECTROVALVE	ELECTRO-VALVULA
12	395379	1	BOBINA	BOBINE	SPULE	COIL	BOBINA
13	395380	1	BOBINA	BOBINE	SPULE	COIL	BOBINA
14	202158	2	CORPO	CORPS	GEHÄUSE	BODY	CUERPO
15	202179	1	FIANCATA	COTE	SEITENWAND	SIDE PANEL	LADO
16	202233	1	FIANCATA	COTE	SEITENWAND	SIDE PANEL	LADO
17	202139	1	KIT TIRANTE	KIT TIRANT	ZUGSTANGESATZ	TIE ROD KIT	KIT TIRANTE
18	202105	2	VALVOLA	SOUPAPE	VENTIL	VALVE	VALVULA
19	202255	1	VALVOLA	SOUPAPE	VENTIL	VALVE	VALVULA
20	202274	1	VALVOLA	SOUPAPE	VENTIL	VALVE	VALVULA
A	202356	1	ELEMENTO ARGANO	ELEMENT TREUIL	WINDEELEMENT	WINCH ELEMENT	ELEM. CABRESTANTE
B	202356	1	ELEM. SFILO PROLUNGA ARTIC.	ELEM. EXTEN. RALL. ARTIC.	GELLENKVER. AUSZIEHENELEM.	JIB EXTENSION ELEM.	ELEM. EXTENSION-EXT. AR.
C	202357	1	ELEM. SNODO PROLUNGA ARTIC.	ELEM. ARTICUL. RALL. ARTIC.	GELLENKVER. GELENKELEM.	JIB ARTICULATION ELEM.	ELEM. ARTICUL. EXT. AR.
D	202355	1	ELEMENTO SFILO BRACCI	ELEMENT EXTENS. BRAS	ARMAUSZIEHENELEMENT	ARM EXTENSION ELEMENT	ELEMENT EXT. BRAZOS
E	202354	1	ELEMENTO BRACCIO PRINCIPALE	ELEMENT BRAS PRINCIPAL	HAUPTARMELEMENT	MAIN ARM ELEMENT	ELEM. BRAZO PRINC.
F	202353	1	ELEMENTO COLONNA	ELEMENT COLONNE	SÄULEELEMENT	COLUMN ELEMENT	ELEMENTO COLUMNNA



DISTRIBUTORE DANFOSS 7 ELEMENTI A - PROLUNGA ARTICOLATA - ARGANO - 197567 (23 P)

* Distributeur DANFOSS - 7 éléments A - rallonge articulée - treuil
* DANFOSS-Steuerventilblock - 7 Elemente A - Gelenkverlängerung - Winde
* DANFOSS control valve block - 7 elements A - jib - winch
* Distribuidor DANFOSS 6 elementos A - extensión articulada - cabrestante

TAV. GN.02.12

matr. G107.0005

21
23 P

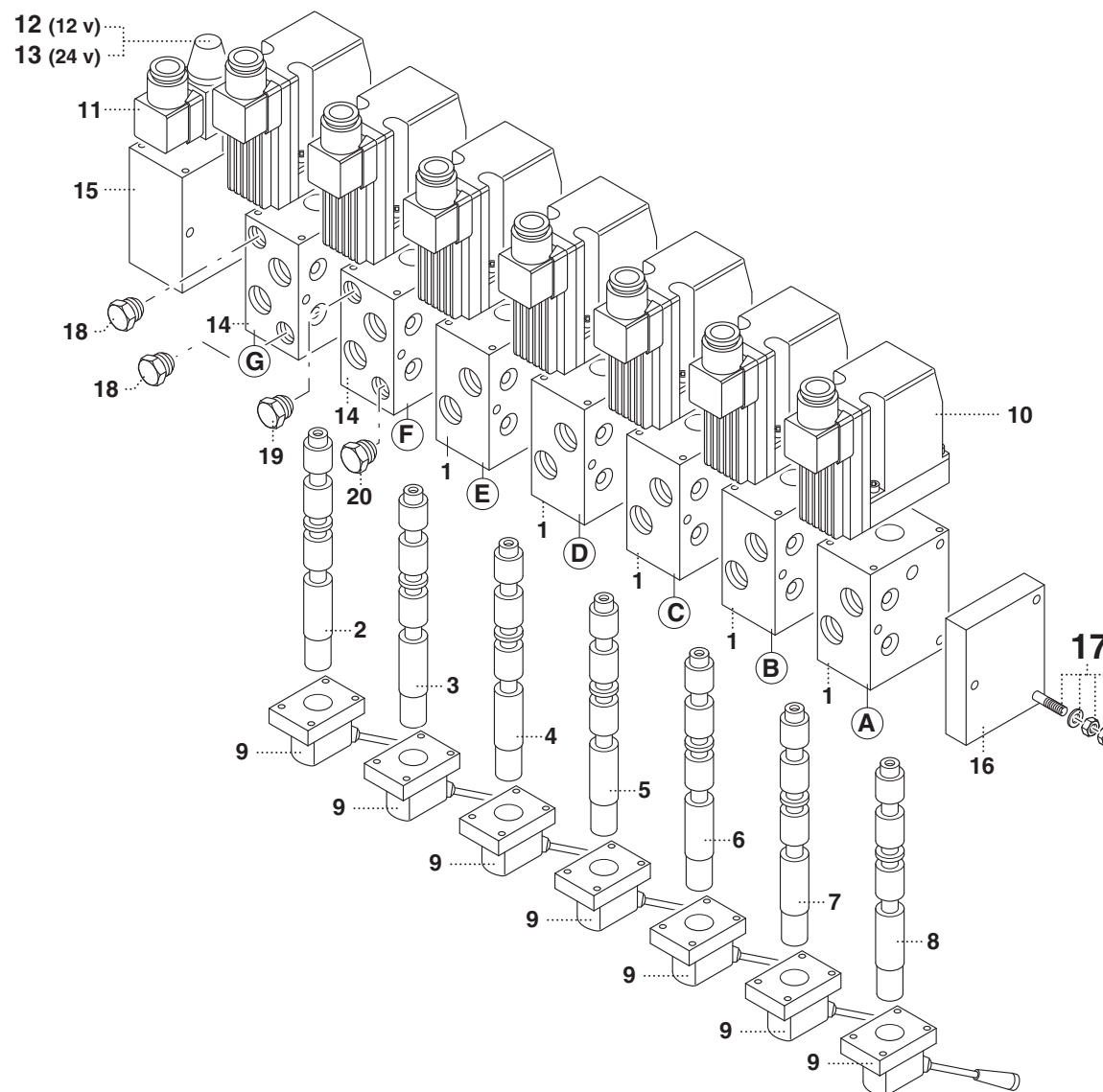



DISTRIBUTORE 5 ELEMENTI - HC - D4/5 - 197665 (21)

- * Distributeur - 5 éléments - HC - D4/5
- * Steuerventilblock - 5 Elemente - HC - D4/5
- * Control valve block - 5 elements - HC - D4/5
- * Distribuidor 5 elementos - HC - D4/5

TAV. GN.04.01

matr. G107.0005

21
23 P

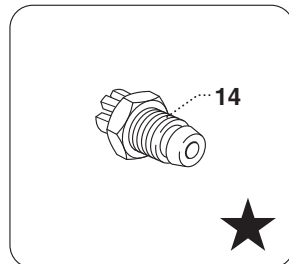
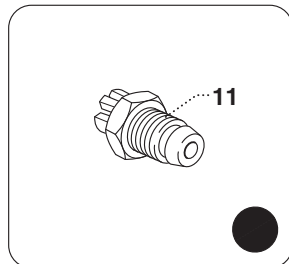
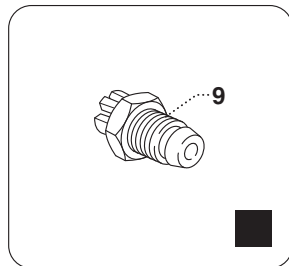
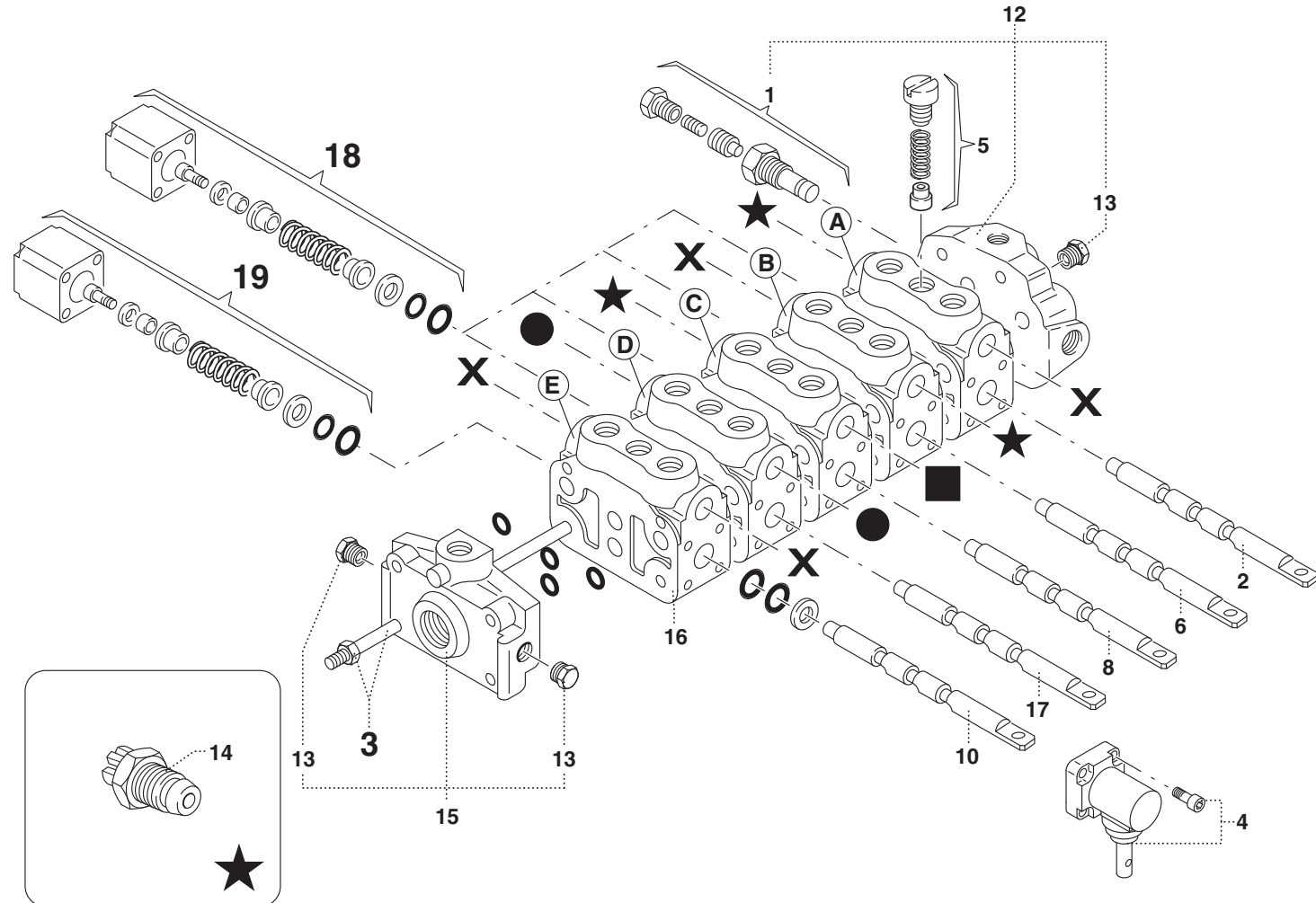
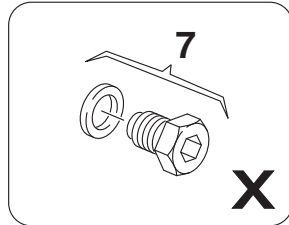

PM 21

matr. G107.0005

TAV. GN.04.01

POS.	N° CODICE	Q.	DESCRIZIONE	DESIGNATION	BENENNUNG	DESCRIPTION	DENOMINACIONES
1	200512	1	VALVOLA	SOUPAPE	VENTIL	VALVE	VALVULA
2	200414	1	ASTA SFILO BRACCI	TIGE EXTENSION BRAS	ARMAUSZIEHENSTANGE	ROD - ARM EXTENSION	VARILLA EXTEN.BRAZOS
3	200457	1	KIT TIRANTE	KIT TIRANT	ZUGSTANGESATZ	TIE ROD KIT	KIT TIRANTE
4	200337	5	ORGANO DI MANOVRA	DISPOSITIF MOUVEMENT	SCHALTVORRICHTUNG	MOTION DEVICE	ORGANO DE MANOVRA
5	200483	5	VALVOLA	SOUPAPE	VENTIL	VALVE	VALVULA
6	200567	1	ASTA BRACCIO PRINCIPALE	TIGE BRAS PRINCIPAL	HAUPTARMSTANGE	MAIN ARM ROD	VARILLA BRAZO PRINC.
7	200325	4	KIT TAPPO	KIT BOUCHON	VERSCHLUSSDECKELSATZ	PLUG KIT	KIT TAPON
8	200566	1	ASTA COLONNA	TIGE COLONNE	SÄULESTANGE	COLUMN ROD	VARILLA COLUMNA
9	200520	1	VALVOLA	SOUPAPE	VENTIL	VALVE	VALVULA
10	200414	1	ASTA STABILIZZATORE	TIGE STABILISATEUR	STABILISATORSTANGE	STABILISATOR ROD	VARILLA ESTABILIZADOR
11	200519	2	VALVOLA	SOUPAPE	VENTIL	VALVE	VALVULA
12	200584	1	FIANCATA	COTE	SEITENWAND	SIDE PANEL	LADO
13	200481	3	TAPPO	BOUCHON	VERSCHLUSSDECKEL	PLUG	TAPON
14	200521	3	VALVOLA	SOUPAPE	VENTIL	VALVE	VALVULA
15	200338	1	FIANCATA	COTE	SEITENWAND	SIDE PANEL	LADO
16	200340	5	CORPO	CORPS	GEHÄUSE	BODY	CUERPO
17	200490	1	ASTA ROTAZIONE	TIGE ROTATION	DREHSTANGE	ROTATION ROD	VARILLA ROTACION
18	200485	4	KIT RICHIAMO	KIT RAPPEL	RÜCKNAHMESATZ	RETURN KIT	KIT LLAMADA
19	200446	1	KIT ATTACCO	KIT ATTACHE	VERBINDUNGSSATZ	COUPLING KIT	KIT CONEXION
	200522	1	KIT GUARNIZIONI	KIT JOINTS	DICHTUNGSSATZ	SEALS KIT	KIT JUNTAS
A	200588	1	ELEMENTO SFILO BRACCI	ELEMENT EXTENS. BRAS	ARMAUSZIEHENELEMENT	ARM EXTENSION ELEMENT	ELEMENT EXT. BRAZOS
B	200587	1	ELEMENTO BRACCIO PRINCIPALE	ELEMENT BRAS PRINCIPAL	HAUPTARMELEMENT	MAIN ARM ELEMENT	ELEM. BRAZO PRINC.
C	200586	1	ELEMENTO COLONNA	ELEMENT COLONNE	SÄULEELEMENT	COLUMN ELEMENT	ELEMENTO COLUMNA
D	200514	1	ELEMENTO ROTAZIONE	ELEMENT ROTATION	DREHUNGELEMENT	ROTATION ELEMENT	ELEMENTO ROTACION
E	200585	1	ELEMENTO STABILIZZATORE	ELEMENT STABILISATEUR	STABILISATORELEMENT	STABILISATOR ELEMENT	ELEM. ESTABILIZADOR

PM 21

matr. G107.0005

TAV. GN.04.02

POS.	N° CODICE	Q.	DESCRIZIONE	DESIGNATION	BENENNUNG	DESCRIPTION	DENOMINACIONES
1	200512	1	VALVOLA	SOUPAPE	VENTIL	VALVE	VALVULA
2	200414	1	ASTA SFILO BRACCI	TIGE EXTENSION BRAS	ARMAUSZIEHENSTANGE	ROD - ARM EXTENSION	VARILLA EXTEN.BRAZOS
3	200320	1	KIT TIRANTE	KIT TIRANT	ZUGSTANGESATZ	TIEROD KIT	KIT TIRANTE
4	200337	6	ORGANO DI MANOVRA	DISPOSITIF MOUVEMENT	SCHALTVORRICHTUNG	MOTION DEVICE	ORGANO DE MANOVRA
5	200483	6	VALVOLA	SOUPAPE	VENTIL	VALVE	VALVULA
6	200567	1	ASTA BRACCIO PRINCIPALE	TIGE BRAS PRINCIPAL	HAUPTARMSTANGE	MAIN ARM ROD	VARILLA BRAZO PRINC.
7	200325	4	KIT TAPPO	KIT BOUCHON	VERSCHLUSSDECKELSATZ	PLUG KIT	KIT TAPON
8	200566	1	ASTA COLONNA	TIGE COLONNE	SÄULESTANGE	COLUMN ROD	VARILLA COLUMNA
9	200520	1	VALVOLA	SOUPAPE	VENTIL	VALVE	VALVULA
10	200414	1	ASTA STABILIZZATORE	TIGE STABILISATEUR	STABILISATORSTANGE	STABILISATOR ROD	VARILLA ESTABILIZADOR
11	200519	4	VALVOLA	SOUPAPE	VENTIL	VALVE	VALVULA
12	200584	1	FIANCATA	COTE	SEITENWAND	SIDE PANEL	LADO
13	200481	3	TAPPO	BOUCHON	VERSCHLUSSDECKEL	PLUG	TAPON
14	200521	3	VALVOLA	SOUPAPE	VENTIL	VALVE	VALVULA
15	200338	1	FIANCATA	COTE	SEITENWAND	SIDE PANEL	LADO
16	200340	6	CORPO	CORPS	GEHÄUSE	BODY	CUERPO
17	200490	1	ASTA ROTAZIONE	TIGE ROTATION	DREHSTANGE	ROTATION ROD	VARILLA ROTACION
18	200485	5	KIT RICHIAMO	KIT RAPPEL	RÜCKNAHMESATZ	RETURN KIT	KIT LLAMADA
19	200446	1	KIT ATTACCO	KIT ATTACHE	VERBINDUNGSSATZ	COUPLING KIT	KIT CONEXION
20	200490	1	ASTA 1° ATTIVAZIONE	TIGE - 1ERE ACTIVATION	STANGE - 1.BETÄTIGUNG	ROD - 1ST ACTIVATION	VARILLA-1ERA ACTIVAC.
	200524		KIT GUARNIZIONI	KIT JOINTS	DICHTUNGSSATZ	SEALS KIT	KIT JUNTAS
A	200588	1	ELEMENTO SFILO BRACCI	ELEMENT EXTENS. BRAS	ARMAUSZIEHENELEMENT	ARM EXTENSION ELEMENT	ELEMENT EXT. BRAZOS
B	200587	1	ELEMENTO BRACCIO PRINCIPALE	ELEMENT BRAS PRINCIPAL	HAUPTARMELEMENT	MAIN ARM ELEMENT	ELEM. BRAZO PRINC.
C	200586	1	ELEMENTO COLONNA	ELEMENT COLONNE	SÄULEELEMENT	COLUMN ELEMENT	ELEMENTO COLUMNA
D	200514	1	ELEMENTO ROTAZIONE	ELEMENT ROTATION	DREHUNGELEMENT	ROTATION ELEMENT	ELEMENTO ROTACION
E	200585	1	ELEMENTO STABILIZZATORE	ELEMENT STABILISATEUR	STABILISATORELEMENT	STABILISATOR ELEMENT	ELEM. ESTABILIZADOR



DISTRIBUTORE 6 ELEMENTI - HC - D4/6 - 197667 (21)

- * Distributeur - 6 éléments - HC D4/6
- * Steuerventilblock - 6 Elemente - HC D4/6
- * Control valve block - 6 elements - HC D4/6
- * Distribuidor 6 elementos - HC D4/6

TAV. GN.04.02

matr. G107.0005

21
23 P

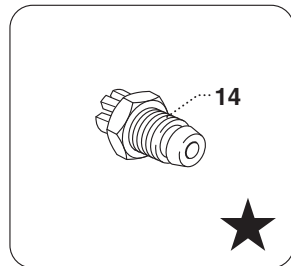
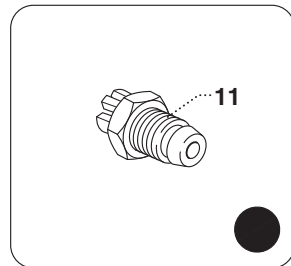
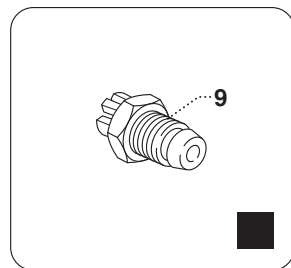
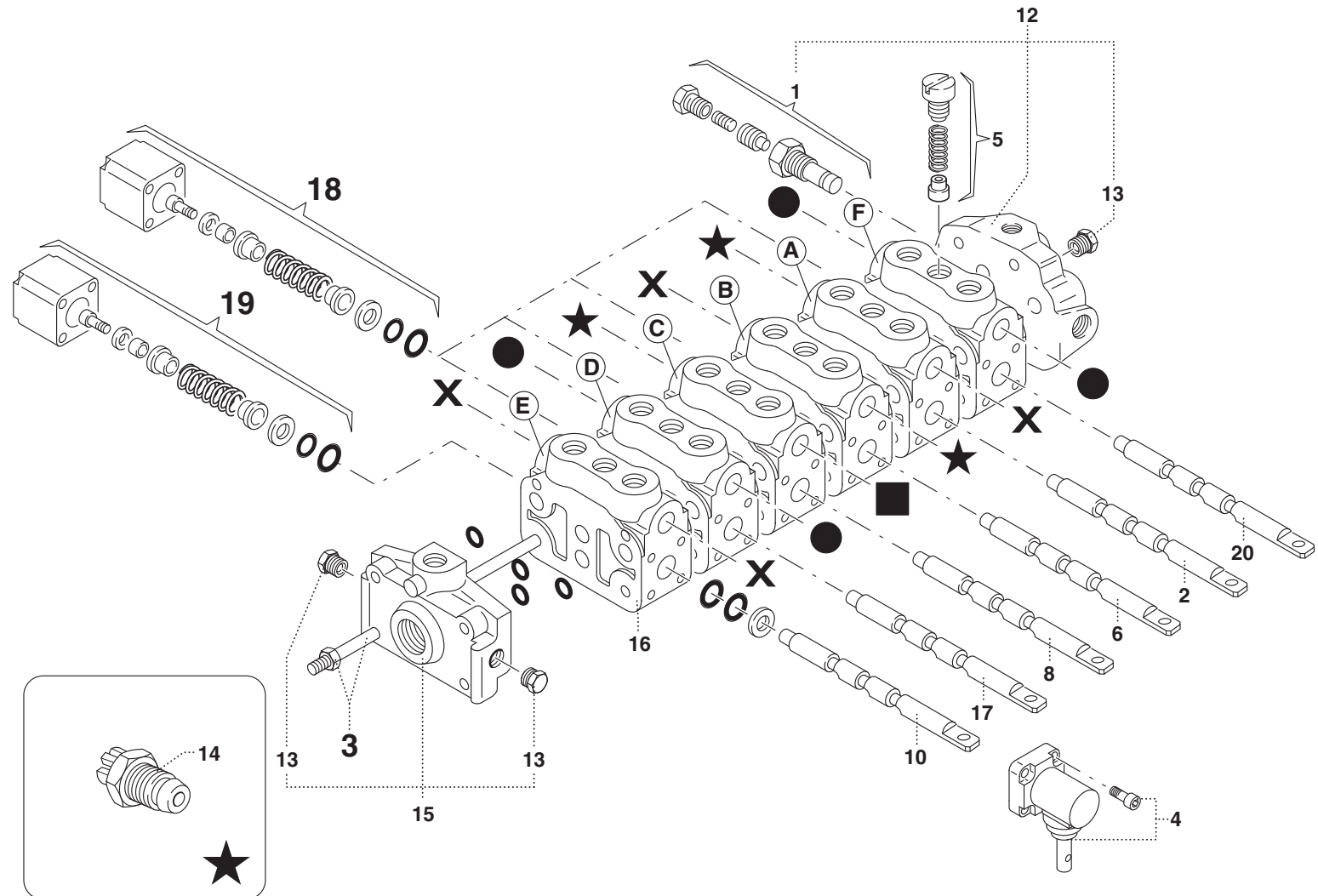
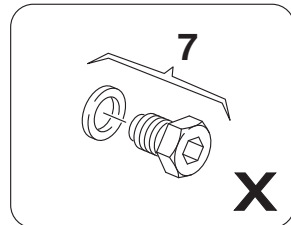



DISTRIBUTORE 7 ELEMENTI - HC D4/7 - 197668 (21)

* Distributeur - 7 éléments - HC D4/7
* Steuerventilblock - 7 Elemente - HC D4/7
* Control valve block - 7 elements - HC D4/7
* Distribuidor 7 elementos - HC D4/7

TAV. GN.04.03

matr. G107.0005

21
23 P

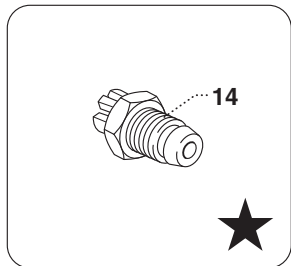
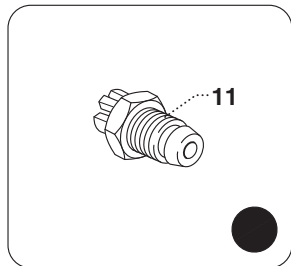
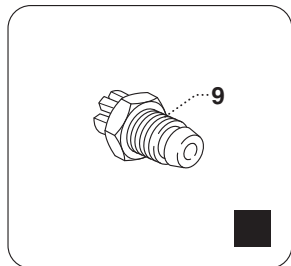
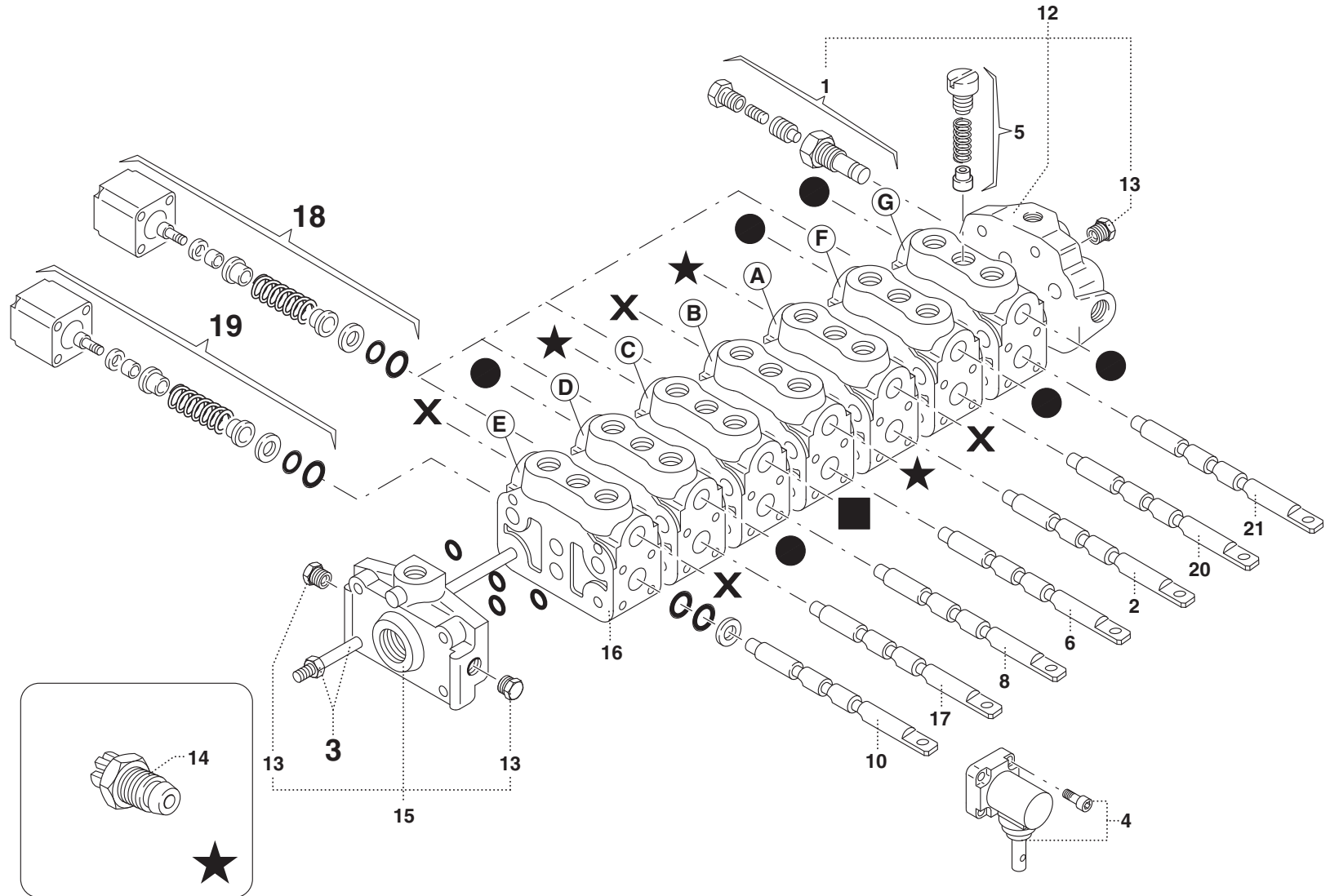
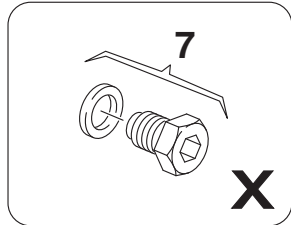

PM 21

matr. G107.0005

TAV. GN.04.03

POS.	N° CODICE	Q.	DESCRIZIONE	DESIGNATION	BENENNUNG	DESCRIPTION	DENOMINACIONES
1	200512	1	VALVOLA	SOUPAPE	VENTIL	VALVE	VALVULA
2	200414	1	ASTA SFILO BRACCI	TIGE EXTENSION BRAS	ARMAUSZIEHENSTANGE	ROD - ARM EXTENSION	VARILLA EXTEN.BRAZOS
3	200313	1	KIT TIRANTE	KIT TIRANT	ZUGSTANGESATZ	TIEROD KIT	KIT TIRANTE
4	200337	7	ORGANO DI MANOVRA	DISPOSITIF MOUVEMENT	SCHALTVORRICHTUNG	MOTION DEVICE	ORGANO DE MANOVRA
5	200483	7	VALVOLA	SOUPAPE	VENTIL	VALVE	VALVULA
6	200567	1	ASTA BRACCIO PRINCIPALE	TIGE BRAS PRINCIPAL	HAUPTARMSTANGE	MAIN ARM ROD	VARILLA BRAZO PRINC.
7	200325	4	KIT TAPPO	KIT BOUCHON	VERSCHLUSSDECKELSATZ	PLUG KIT	KIT TAPON
8	200566	1	ASTA COLONNA	TIGE COLONNE	SÄULESTANGE	COLUMN ROD	VARILLA COLUMNNA
9	200520	1	VALVOLA	SOUPAPE	VENTIL	VALVE	VALVULA
10	200414	1	ASTA STABILIZZATORE	TIGE STABILISATEUR	STABILISATORSTANGE	STABILISATOR ROD	VARILLA ESTABILIZADOR
11	200519	6	VALVOLA	SOUPAPE	VENTIL	VALVE	VALVULA
12	200584	1	FIANCATA	COTE	SEITENWAND	SIDE PANEL	LADO
13	200481	3	TAPPO	BOUCHON	VERSCHLUSSDECKEL	PLUG	TAPON
14	200521	3	VALVOLA	SOUPAPE	VENTIL	VALVE	VALVULA
15	200338	1	FIANCATA	COTE	SEITENWAND	SIDE PANEL	LADO
16	200340	7	CORPO	CORPS	GEHÄUSE	BODY	CUERPO
17	200490	1	ASTA ROTAZIONE	TIGE ROTATION	DREHSTANGE	ROTATION ROD	VARILLA ROTACION
18	200485	6	KIT RICHIAMO	KIT RAPPEL	RÜCKNAHMESATZ	RETURN KIT	KIT LLAMADA
19	200446	1	KIT ATTACCO	KIT ATTACHE	VERBINDUNGSSATZ	COUPLING KIT	KIT CONEXION
20	200490	1	ASTA 1° ATTIVAZIONE	TIGE - 1ERE ACTIVATION	STANGE - 1.BETÄTIGUNG	ROD - 1ST ACTIVATION	VARILLA-1ERA ACTIVAC.
21	200490	1	ASTA 2° ATTIVAZIONE	TIGE - 2EME ACTIVATION	STANGE - 2.BETÄTIGUNG	ROD - 2ND ACTIVATION	VARILLA-2DA ACTIVAC.
	200525		KIT GUARNIZIONI	KIT JOINTS	DICHTUNGSSATZ	SEALS KIT	KIT JUNTAS
A	200588	1	ELEMENTO SFILO BRACCI	ELEMENT EXTENS. BRAS	ARMAUSZIEHENELEMENT	ARM EXTENSION ELEMENT	ELEMENT EXT. BRAZOS
B	200587	1	ELEMENTO BRACCIO PRINCIPALE	ELEMENT BRAS PRINCIPAL	HAUPTARMELEMENT	MAIN ARM ELEMENT	ELEM. BRAZO PRINC.
C	200586	1	ELEMENTO COLONNA	ELEMENT COLONNE	SÄULEELEMENT	COLUMN ELEMENT	ELEMENTO COLUMNNA
D	200514	1	ELEMENTO ROTAZIONE	ELEMENT ROTATION	DREHUNGELEMENT	ROTATION ELEMENT	ELEMENTO ROTACION



DISTRIBUTORE 7 ELEMENTI - HC D4/7 - 197668 (21)

* Distributeur - 7 éléments - HC D4/7
* Steuerventilblock - 7 Elemente - HC D4/7
* Control valve block - 7 elements - HC D4/7
* Distribuidor 7 elementos - HC D4/7

TAV. GN.04.03

matr. G107.0005

21
23 P

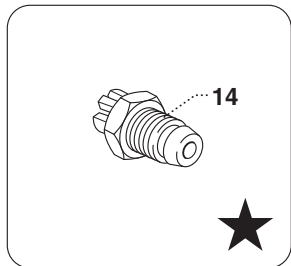
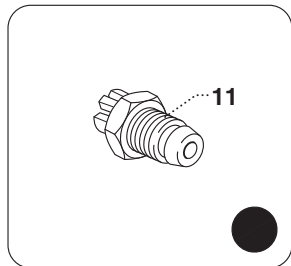
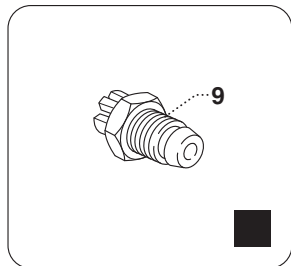
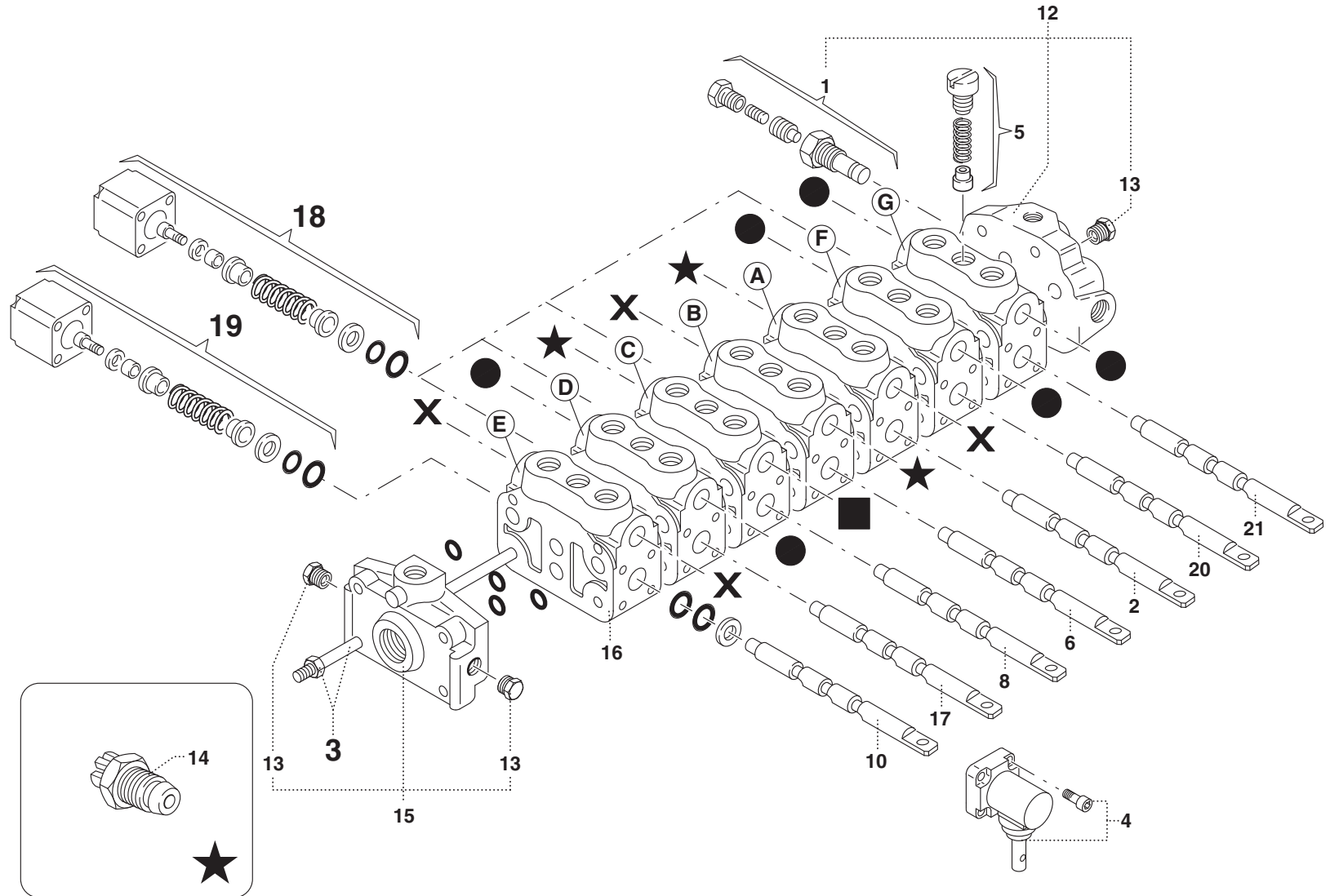
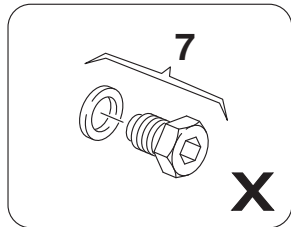



DISTRIBUTORE 6 ELEMENTI - HC - D4/6 - ARGANO - 197666 (21)

- * Distributeur - 6 éléments - HC D4/6 - treuil
- * Steuerventilblock - 6 Elemente - HC D4/6 - Winde
- * Control valve block - 6 elements - HC D4/6 - winch
- * Distribuidor 6 elementos - HC D4/6 - cabrestante

TAV. GN.04.04

matr. G107.0005

21
23 P

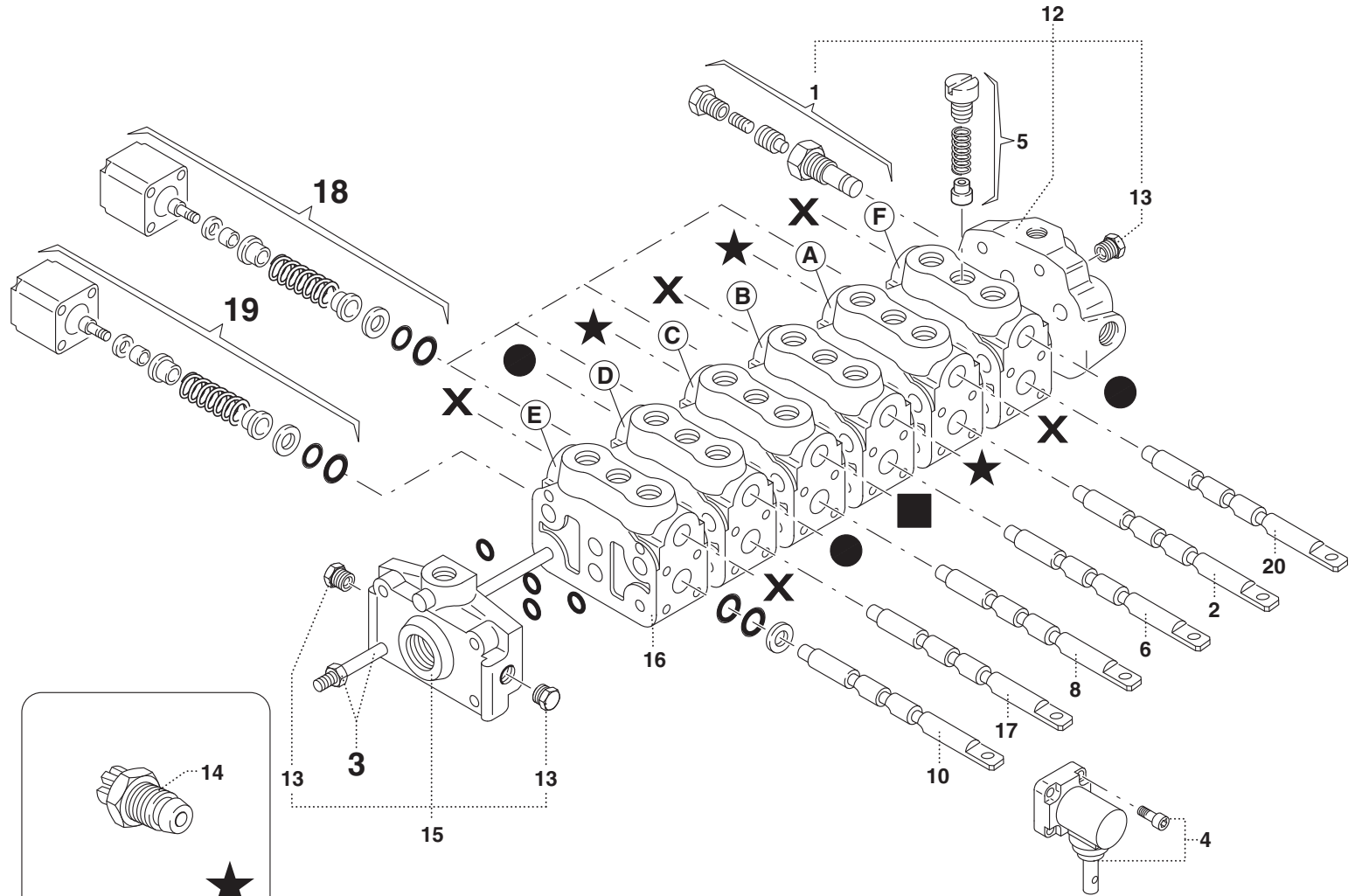
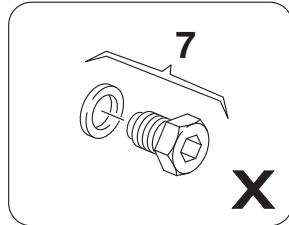

PM 21

matr. G107.0005

TAV. GN.04.04

POS.	N° CODICE	Q.	DESCRIZIONE	DESIGNATION	BENENNUNG	DESCRIPTION	DENOMINACIONES
1	200512	1	VALVOLA	SOUPAPE	VENTIL	VALVE	VALVULA
2	200414	1	ASTA SFILO BRACCI	TIGE EXTENSION BRAS	ARMAUSZIEHENSTANGE	ROD - ARM EXTENSION	VARILLA EXTEN.BRAZOS
3	200320	1	KIT TIRANTE	KIT TIRANT	ZUGSTANGESATZ	TIEROD KIT	KIT TIRANTE
4	200337	6	ORGANO DI MANOVRA	DISPOSITIF MOUVEMENT	SCHALTVORRICHTUNG	MOTION DEVICE	ORGANO DE MANOVRA
5	200483	6	VALVOLA	SOUPAPE	VENTIL	VALVE	VALVULA
6	200567	1	ASTA BRACCIO PRINCIPALE	TIGE BRAS PRINCIPAL	HAUPTARMSTANGE	MAIN ARM ROD	VARILLA BRAZO PRINC.
7	200325	5	KIT TAPPO	KIT BOUCHON	VERSCHLUSSDECKELSATZ	PLUG KIT	KIT TAPON
8	200566	1	ASTA COLONNA	TIGE COLONNE	SÄULESTANGE	COLUMN ROD	VARILLA COLUMNNA
9	200520	1	VALVOLA	SOUPAPE	VENTIL	VALVE	VALVULA
10	200414	1	ASTA STABILIZZATORE	TIGE STABILISATEUR	STABILISATORSTANGE	STABILISATOR ROD	VARILLA ESTABILIZADOR
11	200519	3	VALVOLA	SOUPAPE	VENTIL	VALVE	VALVULA
12	200584	1	FIANCATA	COTE	SEITENWAND	SIDE PANEL	LADO
13	200481	3	TAPPO	BOUCHON	VERSCHLUSSDECKEL	PLUG	TAPON
14	200521	3	VALVOLA	SOUPAPE	VENTIL	VALVE	VALVULA
15	200338	1	FIANCATA	COTE	SEITENWAND	SIDE PANEL	LADO
16	200340	6	CORPO	CORPS	GEHÄUSE	BODY	CUERPO
17	200490	1	ASTA ROTAZIONE	TIGE ROTATION	DREHSTANGE	ROTATION ROD	VARILLA ROTACION
18	200485	5	KIT RICHIAMO	KIT RAPPEL	RÜCKNAHMESATZ	RETURN KIT	KIT LLAMADA
19	200446	1	KIT ATTACCO	KIT ATTACHE	VERBINDUNGSSATZ	COUPLING KIT	KIT CONEXION
20	200414	1	ASTA ARGANO	TIGE TREUIL	WINDESTANGE	WINCH ROD	VARILLA CABRESANTE
	200524		KIT GUARNIZIONI	KIT JOINTS	DICHTUNGSSATZ	SEALS KIT	KIT JUNTAS
A	200588	1	ELEMENTO SFILO BRACCI	ELEMENT EXTENS. BRAS	ARMAUSZIEHENELEMENT	ARM EXTENSION ELEMENT	ELEMENT EXT. BRAZOS
B	200587	1	ELEMENTO BRACCIO PRINCIPALE	ELEMENT BRAS PRINCIPAL	HAUPTARMELEMENT	MAIN ARM ELEMENT	ELEM. BRAZO PRINC.
C	200586	1	ELEMENTO COLONNA	ELEMENT COLONNE	SÄULEELEMENT	COLUMN ELEMENT	ELEMENTO COLUMNNA
D	200514	1	ELEMENTO ROTAZIONE	ELEMENT ROTATION	DREHUNGELEMENT	ROTATION ELEMENT	ELEMENTO ROTACION
E	200585	1	ELEMENTO STABILIZZATORE	ELEMENT STABILISATEUR	STABILISATORELEMENT	STABILISATOR ELEMENT	ELEM. ESTABILIZADOR



DISTRIBUTORE BRACCI STABILIZZATORI WALVOIL - 197534

* Distributeur bras stabilisateurs WALVOIL
* WALVOIL Stützarme Steuerventil
* WALVOIL outrigger arms control valve
* Distribuidor brazos estabilizadores WALVOIL

TAV. GN.05.01

matr. G107.0005

21
23 P

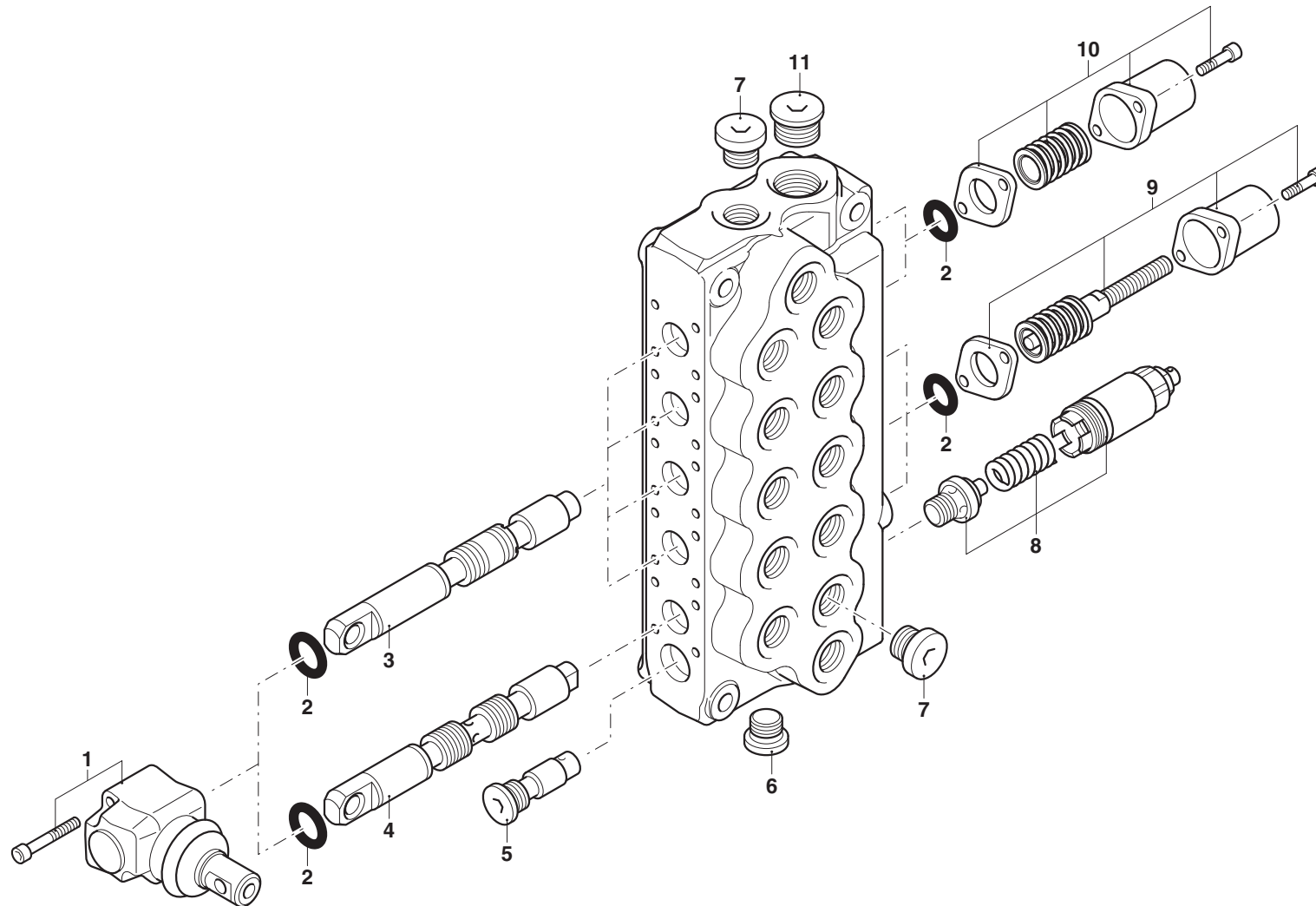



TARGHETTE COMANDI

- * Autocollants commandes
- * Steuerungsschilder
- * Control decals
- * Etiquetas mandos

TAV. GO.01.01

matr. G107.0005

21
23 P

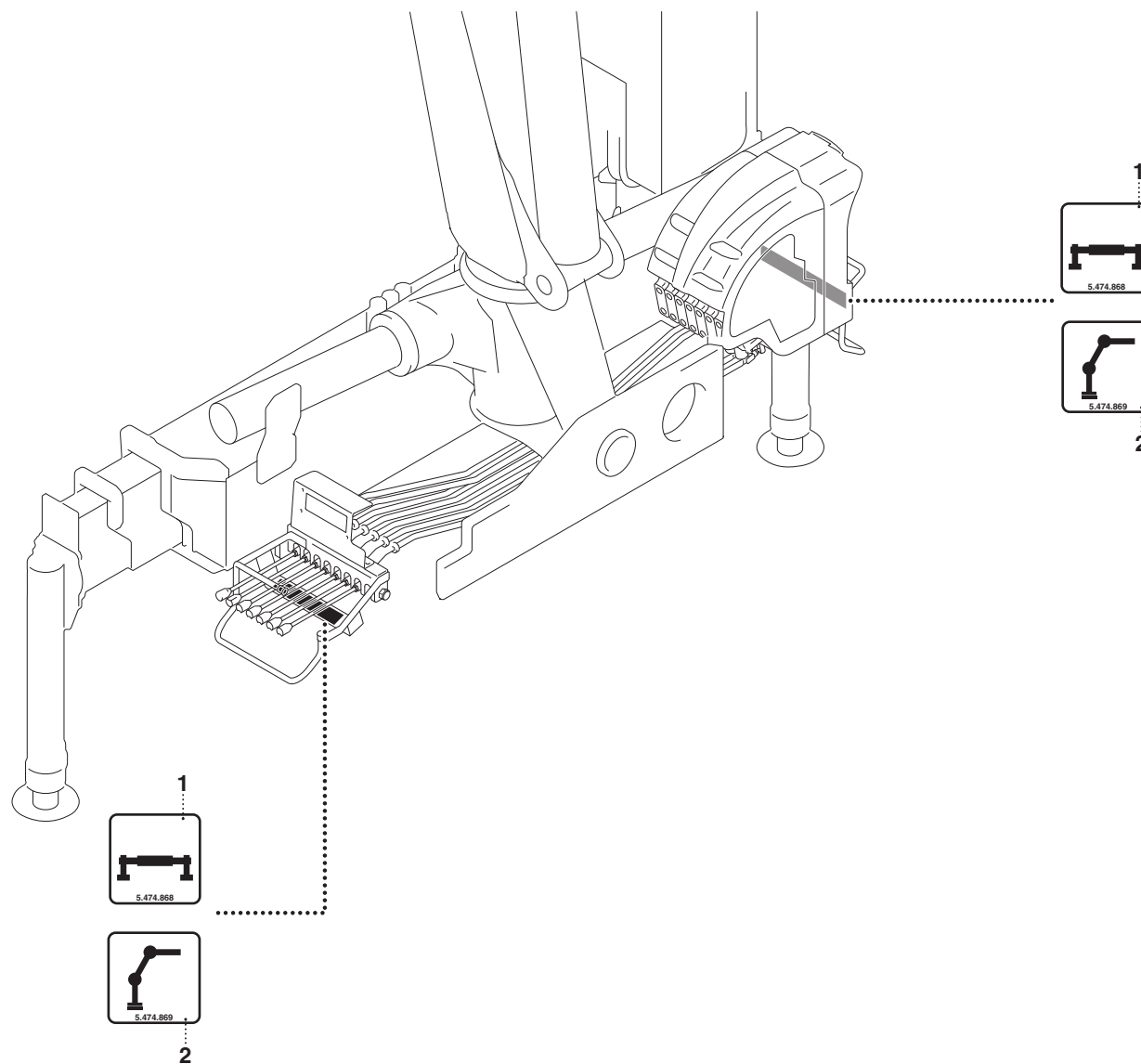



TARGHETTE COMANDI (21)

- * Autocollants commandes
- * Steuerungsschilder
- * Control decals
- * Etiquetas mandos

TAV. GO.01.02

matr. G107.0005

21
23 P

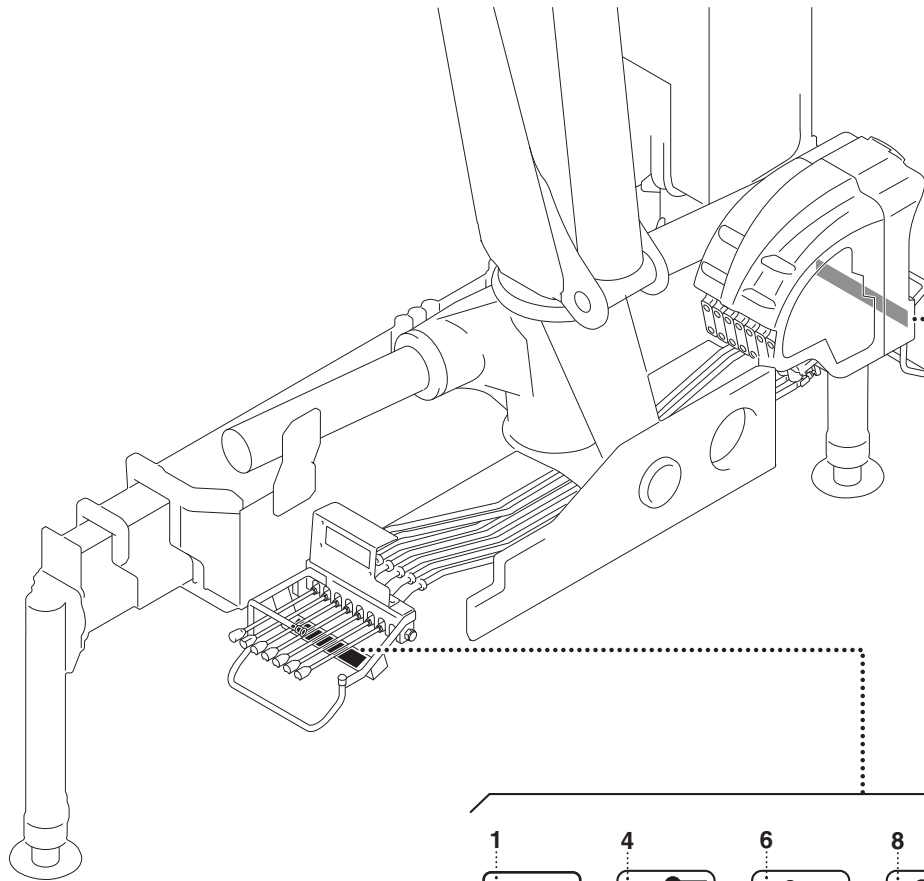

11

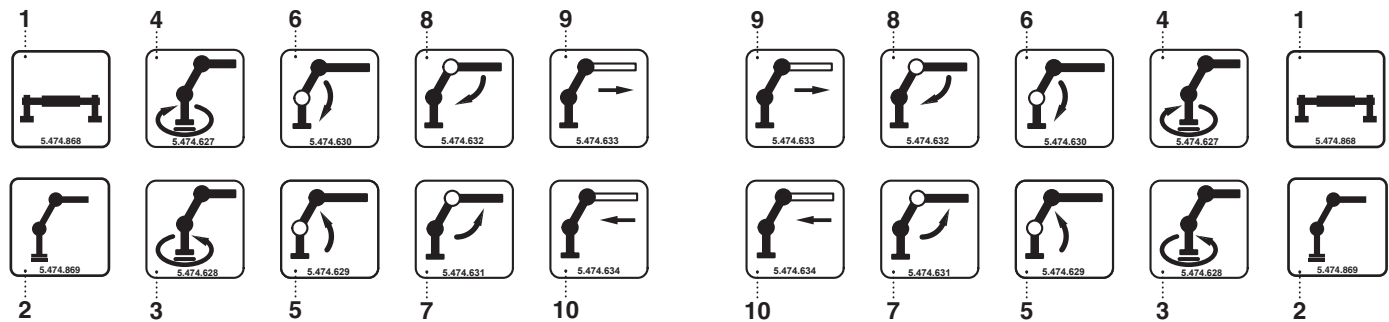



TARGHETTE COMANDI STABILIZZATORI SENZA "MCS"

* Autocollants commandes stabilisateurs sans "MCS"

* Stützsteuerungsschilder ohne "MCS"

* Outriggers control decals without "MCS"

* Etiquetas mandos estabilizadores sin "MCS"

TAV. GO.01.03

matr. G107.0005

21
23 P

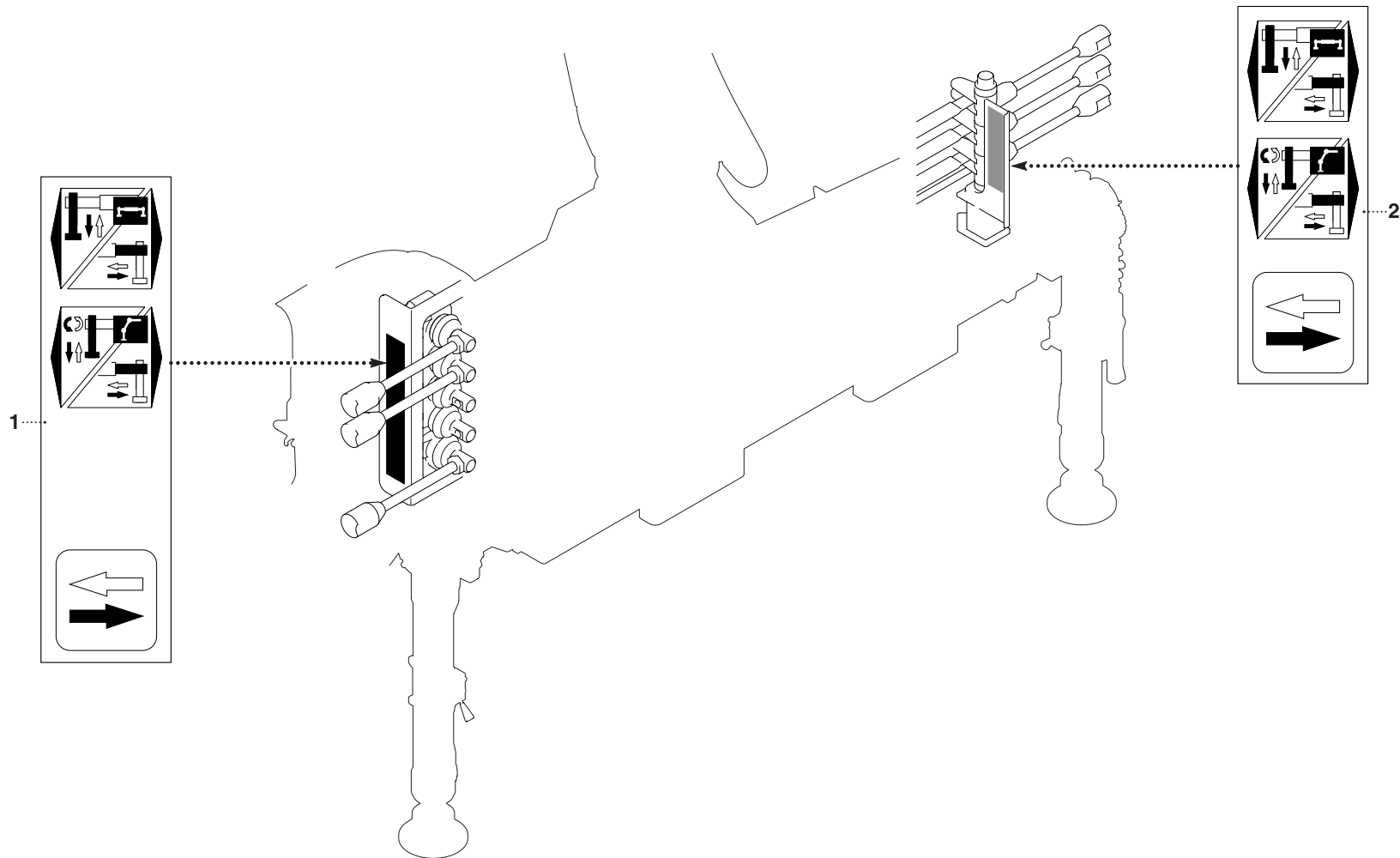



TARGHETTE COMANDI STABILIZZATORI CON "MCS" (23 P)

* Autocollants commandes stabilisateurs avec "MCS"

* Stützsteuerungsschilder mit "MCS"

* Outriggers control decals with "MCS"

* Etiquetas mandos estabilizadores con "MCS"

TAV. GO.01.04

matr. G107.0005

21
23 P

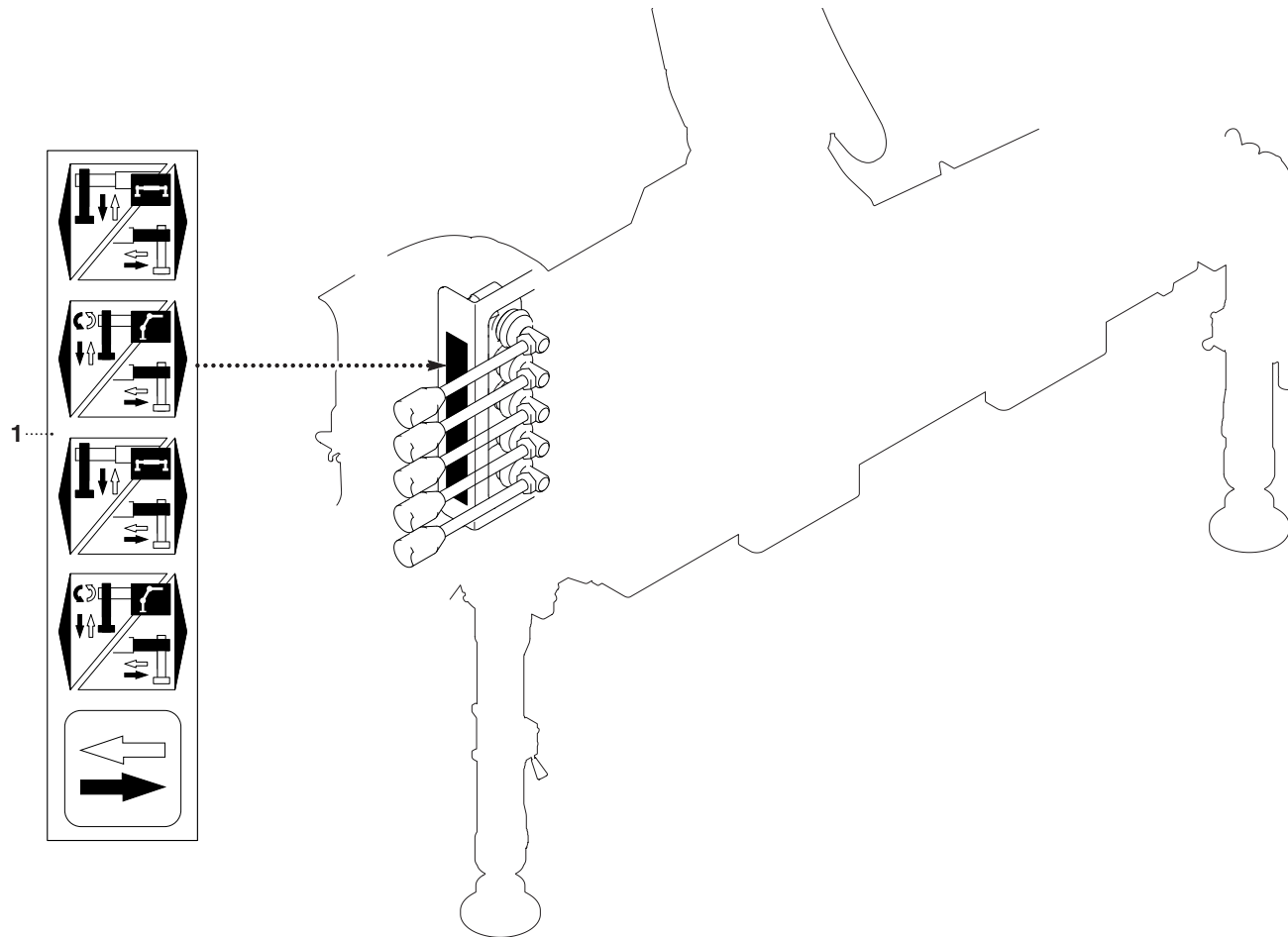



TARGHETTE (21)

- * Autocollants
- * Schilder
- * Decals
- * Etiquetas

TAV. GO.02.01

matr. G107.0005

21
23 P

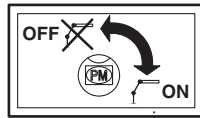

A

20



T

4

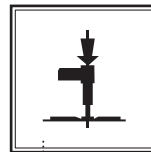

D

5



Q

6

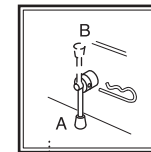

C

7



V

8

L



10



E

1

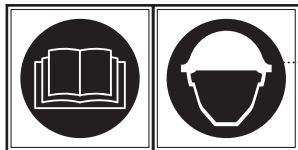

S

9



F

2

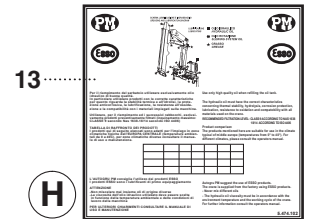
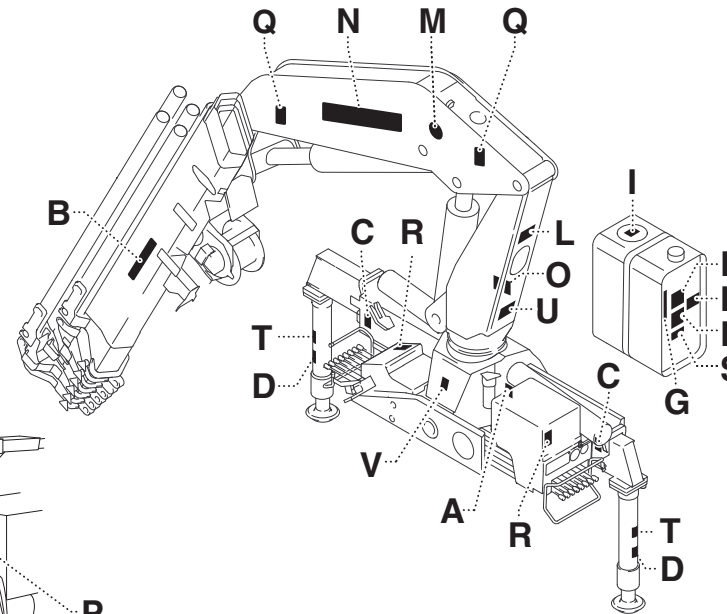

13

H

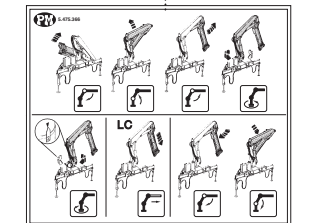

16

U

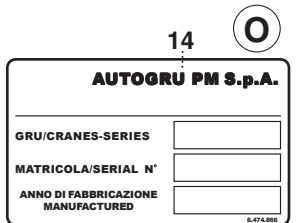

O

14

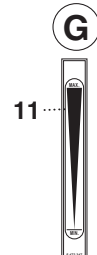

G

11

I

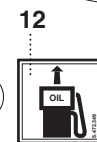

12

B

18



19

N

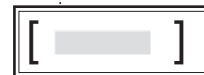

P

15

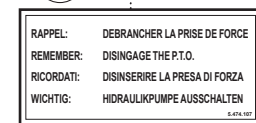

R

3

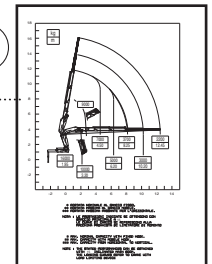

PM 21**matr. G107.0005****TAV. GO.02.01**

POS.		N° CODICE	Q.	DESCRIZIONE	DESIGNATION	BENENNUNG	DESCRIPTION	DENOMINACIONES
1	✘	478539	1	TARGHETTA	AUTOCOLLANT	SCHILD	DECAL	ETIQUETA
2	✘	478540	1	TARGHETTA	AUTOCOLLANT	SCHILD	DECAL	ETIQUETA
3	✦	171395	2	TARGHETTA (21022)	AUTOCOLLANT	SCHILD	DECAL	ETIQUETA
3	*	171396	2	TARGHETTA (21023)	AUTOCOLLANT	SCHILD	DECAL	ETIQUETA
3	▲	171397	2	TARGHETTA (21024)	AUTOCOLLANT	SCHILD	DECAL	ETIQUETA
3	□	171398	2	TARGHETTA (21025)	AUTOCOLLANT	SCHILD	DECAL	ETIQUETA
3	▶	171399	2	TARGHETTA (21026)	AUTOCOLLANT	SCHILD	DECAL	ETIQUETA
3	▼	171400	2	TARGHETTA (21027)	AUTOCOLLANT	SCHILD	DECAL	ETIQUETA
4	■	478542	2	TARGHETTA	AUTOCOLLANT	SCHILD	DECAL	ETIQUETA
5	■	478543	2	TARGHETTA	AUTOCOLLANT	SCHILD	DECAL	ETIQUETA
6	■	478544	4	TARGHETTA	AUTOCOLLANT	SCHILD	DECAL	ETIQUETA
7	■	478545	2	TARGHETTA	AUTOCOLLANT	SCHILD	DECAL	ETIQUETA
8	✘	478546	1	TARGHETTA	AUTOCOLLANT	SCHILD	DECAL	ETIQUETA
9	✘	478547	1	TARGHETTA	AUTOCOLLANT	SCHILD	DECAL	ETIQUETA
10		472126	1	TARGHETTA	AUTOCOLLANT	SCHILD	DECAL	ETIQUETA
11	○	472347	1	TARGHETTA	AUTOCOLLANT	SCHILD	DECAL	ETIQUETA
12	○	472349	1	TARGHETTA	AUTOCOLLANT	SCHILD	DECAL	ETIQUETA
13		474102	1	TARGHETTA	AUTOCOLLANT	SCHILD	DECAL	ETIQUETA
14		474866	1	TARGHETTA	AUTOCOLLANT	SCHILD	DECAL	ETIQUETA
15	■	474107	1	TARGHETTA	AUTOCOLLANT	SCHILD	DECAL	ETIQUETA
16	○	475366	1	TARGHETTA	AUTOCOLLANT	SCHILD	DECAL	ETIQUETA
17	○	474094	2	TARGHETTA	AUTOCOLLANT	SCHILD	DECAL	ETIQUETA
18	○	478444	2	TARGHETTA	AUTOCOLLANT	SCHILD	DECAL	ETIQUETA
19	▲*✦□▶▼	171394	2	TARGHETTA	AUTOCOLLANT	SCHILD	DECAL	ETIQUETA
20	■	478065	1	TARGHETTA	AUTOCOLLANT	SCHILD	DECAL	ETIQUETA



TARGHETTE (21)

- * Autocollants
- * Schilder
- * Decals
- * Etiquetas

TAV. GO.02.01

matr. G107.0005

21
23 P

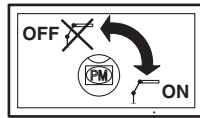

A

20



T

4

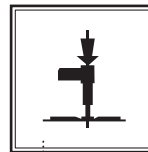

D

5



Q

6

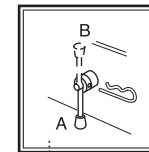

C

7



V

8



L

10



1

E

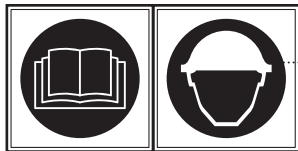

9

S



2

F

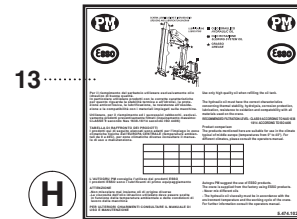
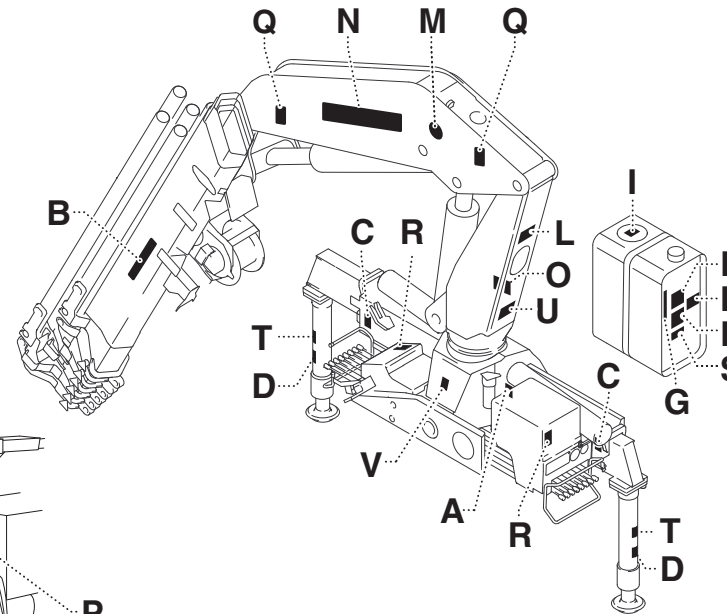

13

H

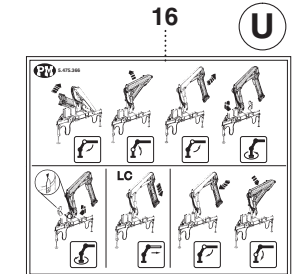

16

U

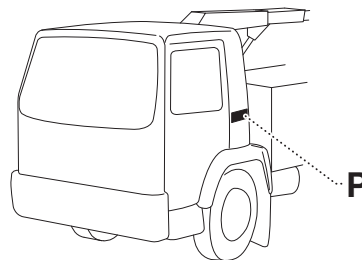

P



14

O

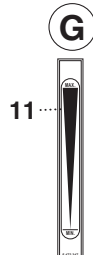

G

11

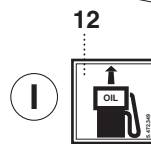

I

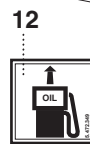

12



18

B

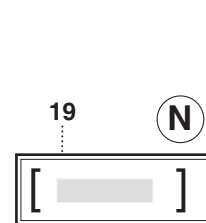

19

N

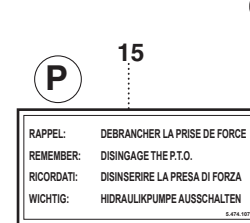

P

15

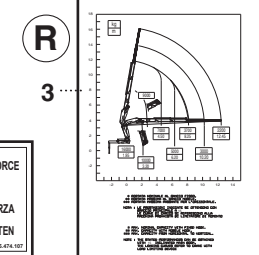

R

3

PM 21

matr. G107.0005

TAV. GO.02.01

POS.	N° CODICE	Q.	DESCRIZIONE	DESIGNATION	BENENNUNG	DESCRIPTION	DENOMINACIONES
■	289953	1	KIT TARGHETTA	KIT AUTOCOLLANT	SCHILDSATZ	DECAL KIT	KIT ETIQUETA
○	289991	1	KIT TARGHETTA	KIT AUTOCOLLANT	SCHILDSATZ	DECAL KIT	KIT ETIQUETA
✖	289907	1	KIT TARGHETTA	KIT AUTOCOLLANT	SCHILDSATZ	DECAL KIT	KIT ETIQUETA
◆	280859	1	KIT TARGHETTA (21022)	KIT AUTOCOLLANT	SCHILDSATZ	DECAL KIT	KIT ETIQUETA
*	280860	1	KIT TARGHETTA (21023)	KIT AUTOCOLLANT	SCHILDSATZ	DECAL KIT	KIT ETIQUETA
▲	280861	1	KIT TARGHETTA (21024)	KIT AUTOCOLLANT	SCHILDSATZ	DECAL KIT	KIT ETIQUETA
□	280862	1	KIT TARGHETTA (21025)	KIT AUTOCOLLANT	SCHILDSATZ	DECAL KIT	KIT ETIQUETA
▶	280863	1	KIT TARGHETTA (21026)	KIT AUTOCOLLANT	SCHILDSATZ	DECAL KIT	KIT ETIQUETA
▼	280864	1	KIT TARGHETTA (21027)	KIT AUTOCOLLANT	SCHILDSATZ	DECAL KIT	KIT ETIQUETA

Nota: ordinare solo i kit targhetta

Nota: ne commander que les kits plaque

Anmerkung: nur den Satz Schilder bestellen

Note: order only plate kits

Nota: ordenar sólo los kit tarjeta



TARGHETTE (21) (LC)

- * Autocollants
- * Schilder
- * Decals
- * Etiquetas

TAV. GO.03.01

matr. G107.0005

21
23 P

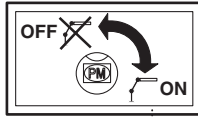

J

21



4

T

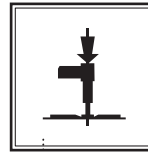

5

D



6

Q

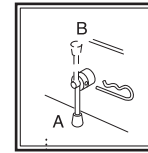

7

C

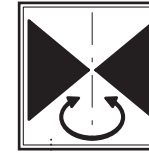

8

V

L



10

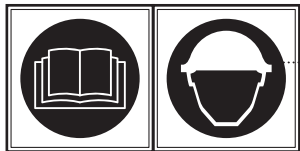

9

S



2

F

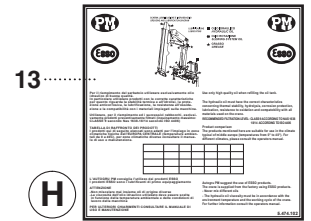
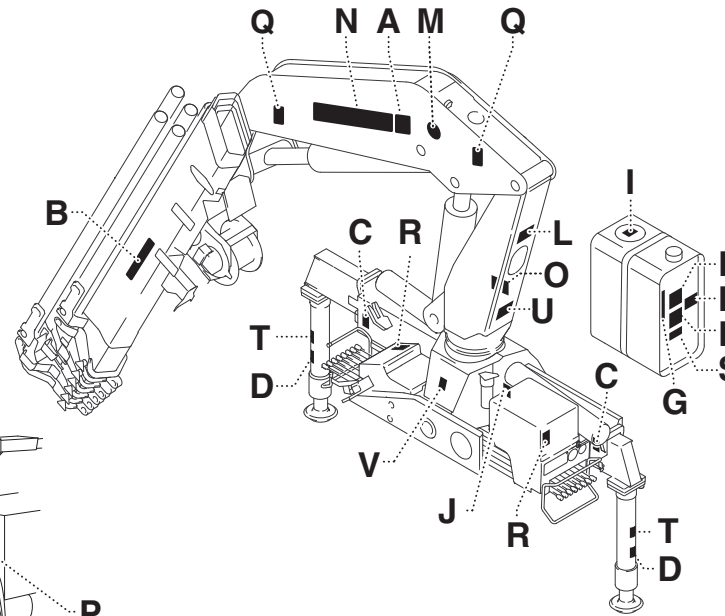

13

H

16

U

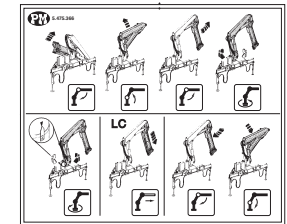

17

M

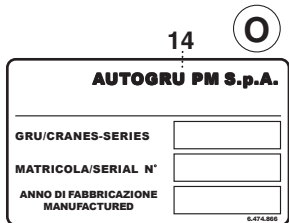

14

O

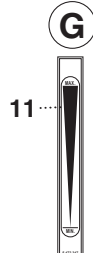

11

G

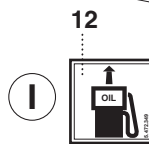

12

I

18

B



19

N

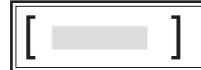

20

A



P

15

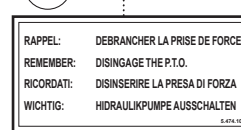

R

3

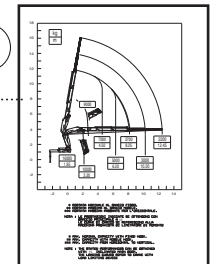

PM 21 LC

matr. G107.0005

TAV. GO.03.01

POS.		N° CODICE	Q.	DESCRIZIONE	DESIGNATION	BENENNUNG	DESCRIPTION	DENOMINACIONES
1	✘	478539	1	TARGHETTA	AUTOCOLLANT	SCHILD	DECAL	ETIQUETA
2	✘	478540	1	TARGHETTA	AUTOCOLLANT	SCHILD	DECAL	ETIQUETA
3	✦	171395	2	TARGHETTA (21022 LC)	AUTOCOLLANT	SCHILD	DECAL	ETIQUETA
3	*	171396	2	TARGHETTA (21023 LC)	AUTOCOLLANT	SCHILD	DECAL	ETIQUETA
3	▲	171397	2	TARGHETTA (21024 LC)	AUTOCOLLANT	SCHILD	DECAL	ETIQUETA
3	□	171398	2	TARGHETTA (21025 LC)	AUTOCOLLANT	SCHILD	DECAL	ETIQUETA
3	▶	171399	2	TARGHETTA (21026 LC)	AUTOCOLLANT	SCHILD	DECAL	ETIQUETA
3	▼	171400	2	TARGHETTA (21027 LC)	AUTOCOLLANT	SCHILD	DECAL	ETIQUETA
4	■	478542	2	TARGHETTA	AUTOCOLLANT	SCHILD	DECAL	ETIQUETA
5	■	478543	2	TARGHETTA	AUTOCOLLANT	SCHILD	DECAL	ETIQUETA
6	■	478544	4	TARGHETTA	AUTOCOLLANT	SCHILD	DECAL	ETIQUETA
7	■	478545	2	TARGHETTA	AUTOCOLLANT	SCHILD	DECAL	ETIQUETA
8	✘	478546	1	TARGHETTA	AUTOCOLLANT	SCHILD	DECAL	ETIQUETA
9	✘	478547	1	TARGHETTA	AUTOCOLLANT	SCHILD	DECAL	ETIQUETA
10		472126	1	TARGHETTA	AUTOCOLLANT	SCHILD	DECAL	ETIQUETA
11	○	472347	1	TARGHETTA	AUTOCOLLANT	SCHILD	DECAL	ETIQUETA
12	○	472349	1	TARGHETTA	AUTOCOLLANT	SCHILD	DECAL	ETIQUETA
13		474102	1	TARGHETTA	AUTOCOLLANT	SCHILD	DECAL	ETIQUETA
14		474866	1	TARGHETTA	AUTOCOLLANT	SCHILD	DECAL	ETIQUETA
15	■	474107	1	TARGHETTA	AUTOCOLLANT	SCHILD	DECAL	ETIQUETA
16	○	475366	1	TARGHETTA	AUTOCOLLANT	SCHILD	DECAL	ETIQUETA
17	○	474094	2	TARGHETTA	AUTOCOLLANT	SCHILD	DECAL	ETIQUETA
18	○	478394	2	TARGHETTA	AUTOCOLLANT	SCHILD	DECAL	ETIQUETA
19	▲*✦□▼	171394	2	TARGHETTA	AUTOCOLLANT	SCHILD	DECAL	ETIQUETA
20	▲*✦□▼	171126	2	TARGHETTA	AUTOCOLLANT	SCHILD	DECAL	ETIQUETA
21	■	478065	1	TARGHETTA	AUTOCOLLANT	SCHILD	DECAL	ETIQUETA



TARGHETTE (21) (LC)

- * Autocollants
- * Schilder
- * Decals
- * Etiquetas

TAV. GO.03.01

matr. G107.0005

21
23 P

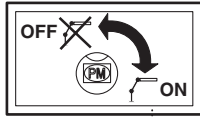

J

21



4

T

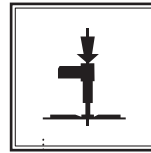

5

D



6

Q

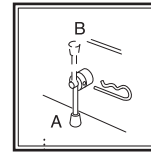

7

C

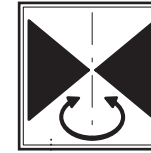

8

V

L



10

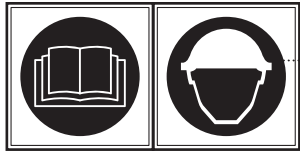

9

S



2

F

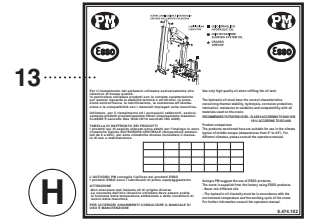
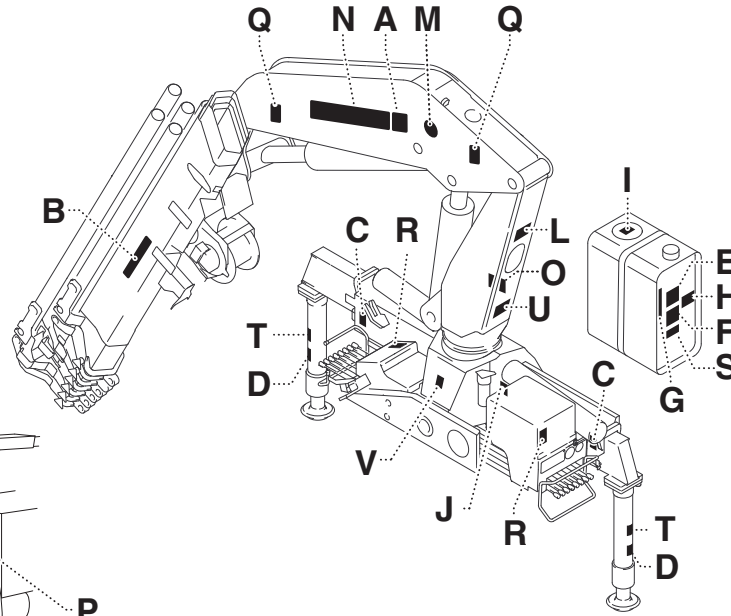

13

H

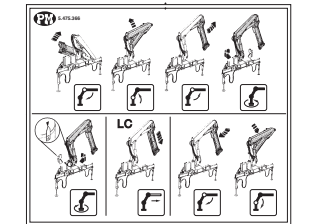

16

U

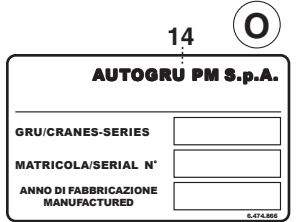

14

O

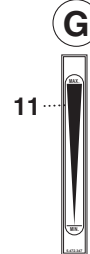

G

11

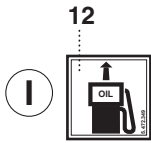

I



12

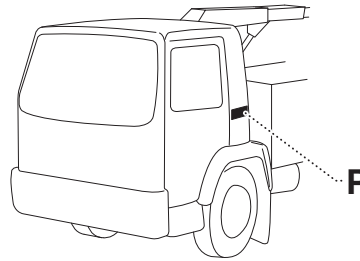

P



18

B

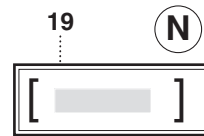

19

N

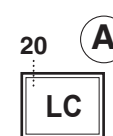

20

A

LC

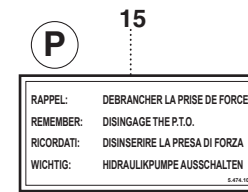

P

15

R

3

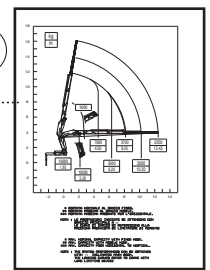

PM 21 LC

matr. G107.0005

TAV. GO.03.01

POS.	N° CODICE	Q.	DESCRIZIONE	DESIGNATION	BENENNUNG	DESCRIPTION	DENOMINACIONES
■	289953	1	KIT TARGHETTA	KIT AUTOCOLLANT	SCHILDSATZ	DECAL KIT	KIT ETIQUETA
○	289991	1	KIT TARGHETTA	KIT AUTOCOLLANT	SCHILDSATZ	DECAL KIT	KIT ETIQUETA
✖	289907	1	KIT TARGHETTA	KIT AUTOCOLLANT	SCHILDSATZ	DECAL KIT	KIT ETIQUETA
◆	280865	1	KIT TARGHETTA (21022 LC)	KIT AUTOCOLLANT	SCHILDSATZ	DECAL KIT	KIT ETIQUETA
*	280866	1	KIT TARGHETTA (21023 LC)	KIT AUTOCOLLANT	SCHILDSATZ	DECAL KIT	KIT ETIQUETA
▲	280867	1	KIT TARGHETTA (21024 LC)	KIT AUTOCOLLANT	SCHILDSATZ	DECAL KIT	KIT ETIQUETA
□	280868	1	KIT TARGHETTA (21025 LC)	KIT AUTOCOLLANT	SCHILDSATZ	DECAL KIT	KIT ETIQUETA
▶	280869	1	KIT TARGHETTA (21026 LC)	KIT AUTOCOLLANT	SCHILDSATZ	DECAL KIT	KIT ETIQUETA
▼	280870	1	KIT TARGHETTA (21027 LC)	KIT AUTOCOLLANT	SCHILDSATZ	DECAL KIT	KIT ETIQUETA

Nota: ordinare solo i kit targhetta

Nota: ne commander que les kits plaque

Anmerkung: nur den Satz Schilder bestellen

Note: order only plate kits

Nota: ordenar sólo los kit tarjeta



TARGHETTE (23 P)

- * Autocollants
- * Schilder
- * Decals
- * Etiquetas

TAV. GO.04.01

matr. G107.0005

21
23 P

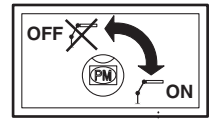

A

20



T

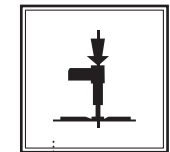

D



Q

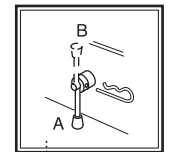

C



V



L

10

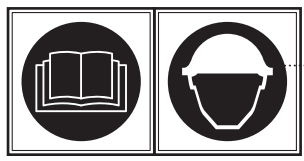

S



F

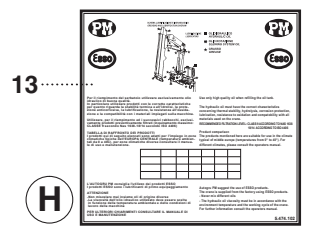
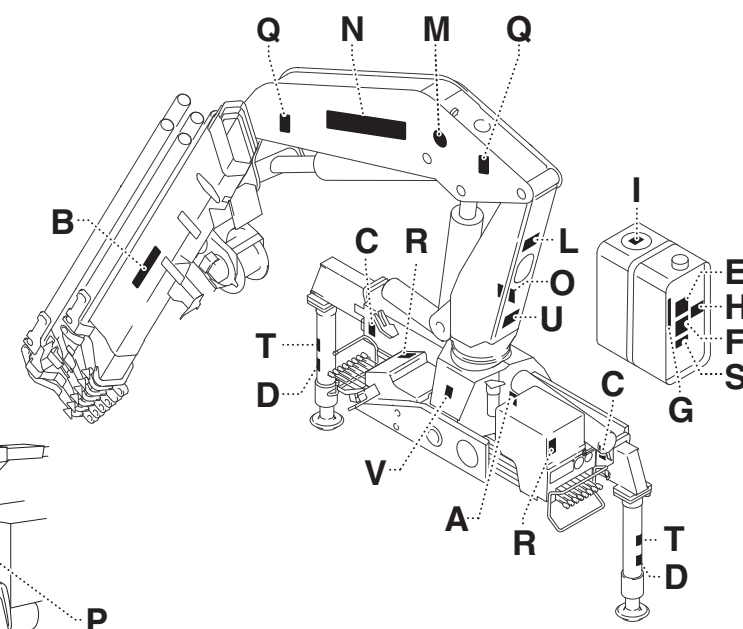

H

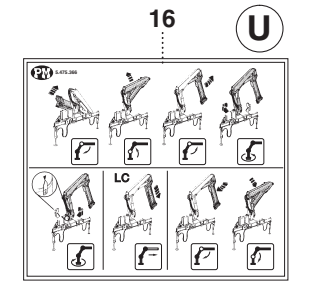

U

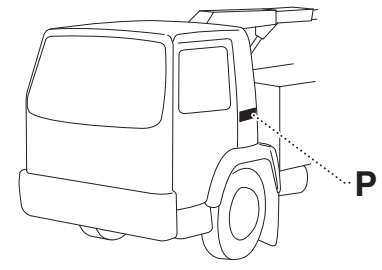

14 O

AUTOGRU PM S.p.A.

GRU/CRANES-SERIES

MATRICOLO/SERIAL N°

ANNO DI FABBRICAZIONE MANUFACTURED

G.474.886

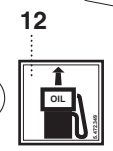
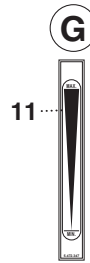

18 B

[www.autogruppm.com]

19 N

[]

P 15

RAPPEL: DEBRANCHER LA PRISE DE FORCE
REMEMBER: DISINGAGE THE P.T.O.
RICORDATI: DISINSERIRE LA PRESA DI FORZA
WICHTIG: HYDRAULIKPUMPE AUSSCHALTEN

G.474.107

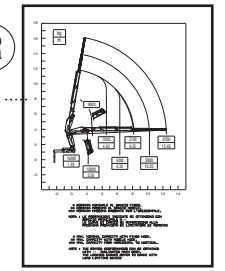

PM 23 P

matr. G107.0005

TAV. GO.04.01

POS.		N° CODICE	Q.	DESCRIZIONE	DESIGNATION	BENENNUNG	DESCRIPTION	DENOMINACIONES
1	✘	478539	1	TARGHETTA	AUTOCOLLANT	SCHILD	DECAL	ETIQUETA
2	✘	478540	1	TARGHETTA	AUTOCOLLANT	SCHILD	DECAL	ETIQUETA
3	✦	171402	2	TARGHETTA (23022 P)	AUTOCOLLANT	SCHILD	DECAL	ETIQUETA
3	*	171403	2	TARGHETTA (23023 P)	AUTOCOLLANT	SCHILD	DECAL	ETIQUETA
3	▲	171404	2	TARGHETTA (23024 P)	AUTOCOLLANT	SCHILD	DECAL	ETIQUETA
3	□	171405	2	TARGHETTA (23025 P)	AUTOCOLLANT	SCHILD	DECAL	ETIQUETA
3	▷	171406	2	TARGHETTA (23026 P)	AUTOCOLLANT	SCHILD	DECAL	ETIQUETA
3	▼	171407	2	TARGHETTA (23027 P)	AUTOCOLLANT	SCHILD	DECAL	ETIQUETA
4	■	478542	2	TARGHETTA	AUTOCOLLANT	SCHILD	DECAL	ETIQUETA
5	■	478543	2	TARGHETTA	AUTOCOLLANT	SCHILD	DECAL	ETIQUETA
6	■	478544	4	TARGHETTA	AUTOCOLLANT	SCHILD	DECAL	ETIQUETA
7	■	478545	2	TARGHETTA	AUTOCOLLANT	SCHILD	DECAL	ETIQUETA
8	✘	478546	1	TARGHETTA	AUTOCOLLANT	SCHILD	DECAL	ETIQUETA
9	✘	478547	1	TARGHETTA	AUTOCOLLANT	SCHILD	DECAL	ETIQUETA
10		472126	1	TARGHETTA	AUTOCOLLANT	SCHILD	DECAL	ETIQUETA
11	○	472347	1	TARGHETTA	AUTOCOLLANT	SCHILD	DECAL	ETIQUETA
12	○	472349	1	TARGHETTA	AUTOCOLLANT	SCHILD	DECAL	ETIQUETA
13		474102	1	TARGHETTA	AUTOCOLLANT	SCHILD	DECAL	ETIQUETA
14		474866	1	TARGHETTA	AUTOCOLLANT	SCHILD	DECAL	ETIQUETA
15	■	474107	1	TARGHETTA	AUTOCOLLANT	SCHILD	DECAL	ETIQUETA
16	○	475366	1	TARGHETTA	AUTOCOLLANT	SCHILD	DECAL	ETIQUETA
17	○	474094	2	TARGHETTA	AUTOCOLLANT	SCHILD	DECAL	ETIQUETA
18	○	478444	2	TARGHETTA	AUTOCOLLANT	SCHILD	DECAL	ETIQUETA
19	▲*✦□▼	171401	2	TARGHETTA	AUTOCOLLANT	SCHILD	DECAL	ETIQUETA
20	■	478065	1	TARGHETTA	AUTOCOLLANT	SCHILD	DECAL	ETIQUETA



TARGHETTE (23 P)

- * Autocollants
- * Schilder
- * Decals
- * Etiquetas

TAV. GO.04.01

matr. G107.0005

21
23 P

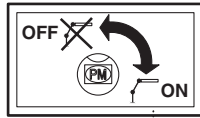

A 20



4 T



5 D



6 Q

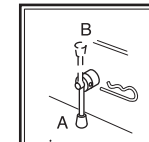

7 C



8 V



L 10



1 E

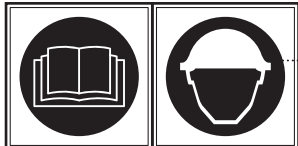

9 S



2 F

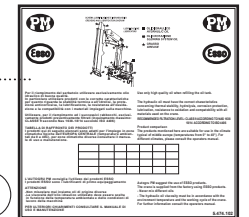
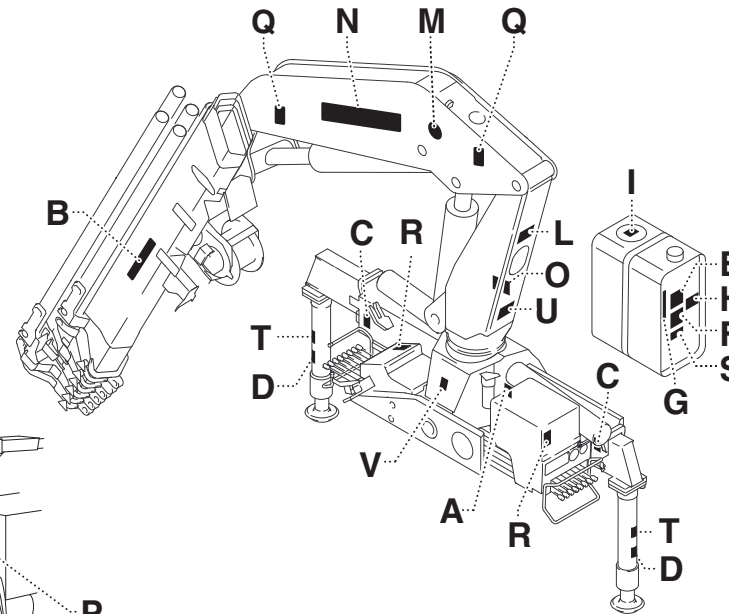

13 H

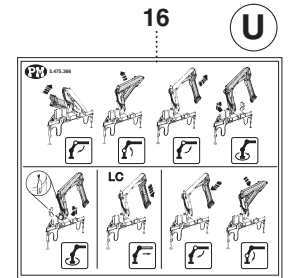

16 U

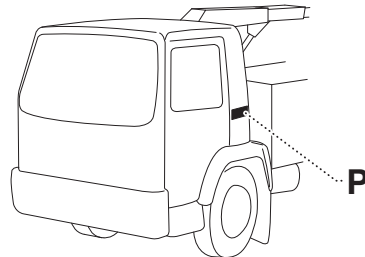

P

14 O

AUTOGRU PM S.p.A.

GRU/CRANES-SERIES

MATRICOLO/SERIAL N°

ANNO DI FABBRICAZIONE MANUFACTURED

G.474.006

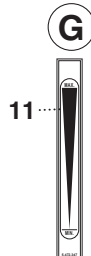

G

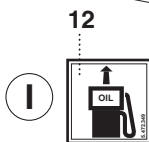

I

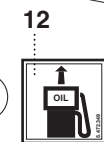

12

18 B

[www.autogruppm.com]

19 N

[]

P 15

RAPPEL: DEBRANCHER LA PRISE DE FORCE
REMEMBER: DISINGAGE THE P.T.O.
RICORDATI: DISINSERIRE LA PRESA DI FORZA
WICHTIG: HYDRAULIKPUMPE AUSSCHALTEN

G.474.007

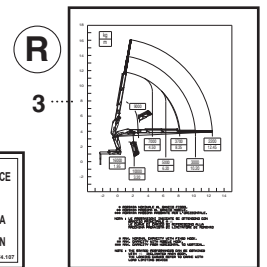

R 3



17 M

PM 23 P

matr. G107.0005

TAV. GO.04.01

POS.	N° CODICE	Q.	DESCRIZIONE	DESIGNATION	BENENNUNG	DESCRIPTION	DENOMINACIONES
■	289953	1	KIT TARGHETTA	KIT AUTOCOLLANT	SCHILDSATZ	DECAL KIT	KIT ETIQUETA
○	289991	1	KIT TARGHETTA	KIT AUTOCOLLANT	SCHILDSATZ	DECAL KIT	KIT ETIQUETA
✖	289907	1	KIT TARGHETTA	KIT AUTOCOLLANT	SCHILDSATZ	DECAL KIT	KIT ETIQUETA
◆	280871	1	KIT TARGHETTA (23022 P)	KIT AUTOCOLLANT	SCHILDSATZ	DECAL KIT	KIT ETIQUETA
*	280872	1	KIT TARGHETTA (23023 P)	KIT AUTOCOLLANT	SCHILDSATZ	DECAL KIT	KIT ETIQUETA
▲	280873	1	KIT TARGHETTA (23024 P)	KIT AUTOCOLLANT	SCHILDSATZ	DECAL KIT	KIT ETIQUETA
□	280874	1	KIT TARGHETTA (23025 P)	KIT AUTOCOLLANT	SCHILDSATZ	DECAL KIT	KIT ETIQUETA
▶	280875	1	KIT TARGHETTA (23026 P)	KIT AUTOCOLLANT	SCHILDSATZ	DECAL KIT	KIT ETIQUETA
▼	280876	1	KIT TARGHETTA (23027 P)	KIT AUTOCOLLANT	SCHILDSATZ	DECAL KIT	KIT ETIQUETA

Nota: ordinare solo i kit targhetta

Nota: ne commander que les kits plaque

Anmerkung: nur den Satz Schilder bestellen

Note: order only plate kits

Nota: ordenar sólo los kit tarjeta



TARGHETTE (23 P) (LC)

- * Autocollants
- * Schilder
- * Decals
- * Etiquetas

TAV. GO.05.01

matr. G107.0005

21
23 P

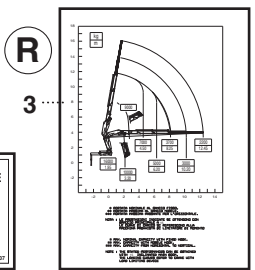
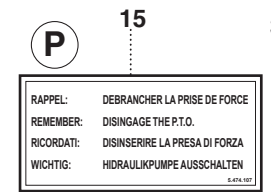
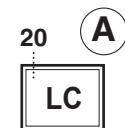
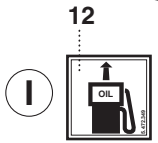
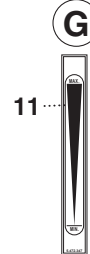
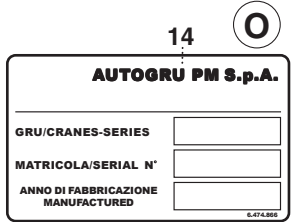
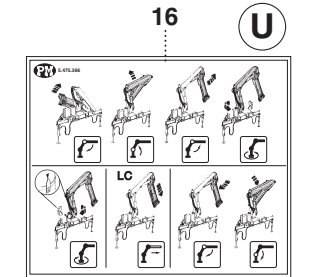
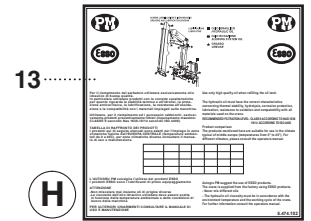
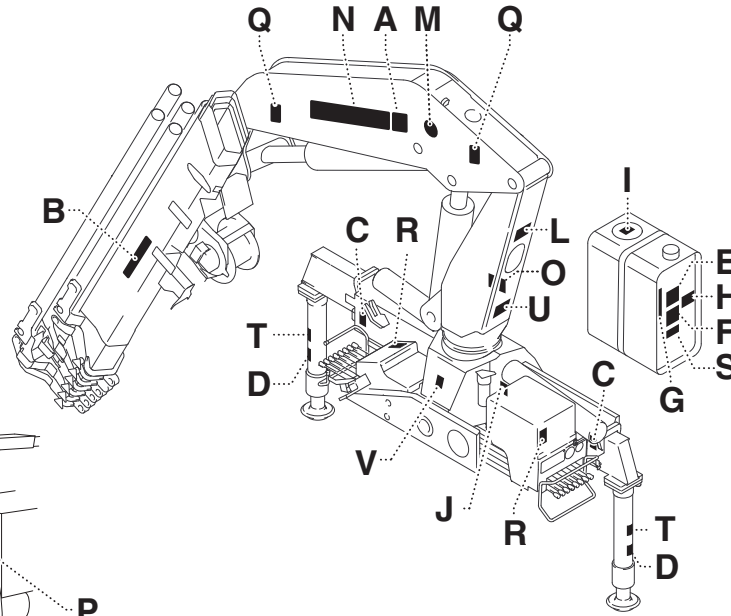
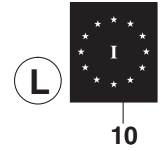
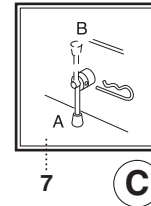
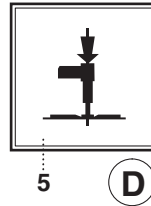
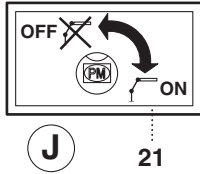

PM 23 P LC

matr. G107.0005

TAV. GO.05.01

POS.		N° CODICE	Q.	DESCRIZIONE	DESIGNATION	BENENNUNG	DESCRIPTION	DENOMINACIONES
1	✘	478539	1	TARGHETTA	AUTOCOLLANT	SCHILD	DECAL	ETIQUETA
2	✘	478540	1	TARGHETTA	AUTOCOLLANT	SCHILD	DECAL	ETIQUETA
3	✦	171402	2	TARGHETTA (23022 P LC)	AUTOCOLLANT	SCHILD	DECAL	ETIQUETA
3	*	171403	2	TARGHETTA (23023 P LC)	AUTOCOLLANT	SCHILD	DECAL	ETIQUETA
3	▲	171404	2	TARGHETTA (23024 P LC)	AUTOCOLLANT	SCHILD	DECAL	ETIQUETA
3	□	171405	2	TARGHETTA (23025 P LC)	AUTOCOLLANT	SCHILD	DECAL	ETIQUETA
3	▶	171406	2	TARGHETTA (23026 P LC)	AUTOCOLLANT	SCHILD	DECAL	ETIQUETA
3	▼	171407	2	TARGHETTA (23027 P LC)	AUTOCOLLANT	SCHILD	DECAL	ETIQUETA
4	■	478542	2	TARGHETTA	AUTOCOLLANT	SCHILD	DECAL	ETIQUETA
5	■	478543	2	TARGHETTA	AUTOCOLLANT	SCHILD	DECAL	ETIQUETA
6	■	478544	4	TARGHETTA	AUTOCOLLANT	SCHILD	DECAL	ETIQUETA
7	■	478545	2	TARGHETTA	AUTOCOLLANT	SCHILD	DECAL	ETIQUETA
8	✘	478546	1	TARGHETTA	AUTOCOLLANT	SCHILD	DECAL	ETIQUETA
9	✘	478547	1	TARGHETTA	AUTOCOLLANT	SCHILD	DECAL	ETIQUETA
10		472126	1	TARGHETTA	AUTOCOLLANT	SCHILD	DECAL	ETIQUETA
11	○	472347	1	TARGHETTA	AUTOCOLLANT	SCHILD	DECAL	ETIQUETA
12	○	472349	1	TARGHETTA	AUTOCOLLANT	SCHILD	DECAL	ETIQUETA
13		474102	1	TARGHETTA	AUTOCOLLANT	SCHILD	DECAL	ETIQUETA
14		474866	1	TARGHETTA	AUTOCOLLANT	SCHILD	DECAL	ETIQUETA
15	■	474107	1	TARGHETTA	AUTOCOLLANT	SCHILD	DECAL	ETIQUETA
16	○	475366	1	TARGHETTA	AUTOCOLLANT	SCHILD	DECAL	ETIQUETA
17	○	474094	2	TARGHETTA	AUTOCOLLANT	SCHILD	DECAL	ETIQUETA
18	○	478394	2	TARGHETTA	AUTOCOLLANT	SCHILD	DECAL	ETIQUETA
19	▲*✦□▼	171401	2	TARGHETTA	AUTOCOLLANT	SCHILD	DECAL	ETIQUETA
20	▲*✦□▼	171126	2	TARGHETTA	AUTOCOLLANT	SCHILD	DECAL	ETIQUETA
21	■	478065	1	TARGHETTA	AUTOCOLLANT	SCHILD	DECAL	ETIQUETA



TARGHETTE (23 P) (LC)

- * Autocollants
- * Schilder
- * Decals
- * Etiquetas

TAV. GO.05.01

matr. G107.0005

21
23 P

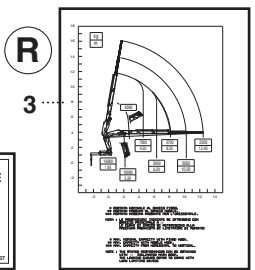
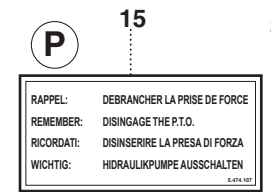
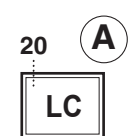
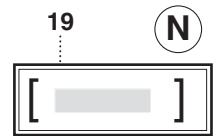
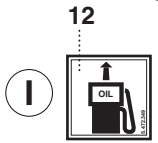
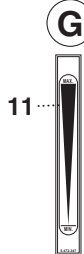
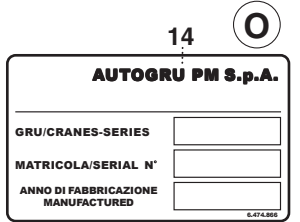
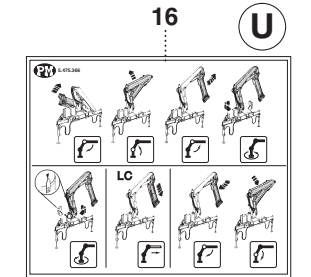
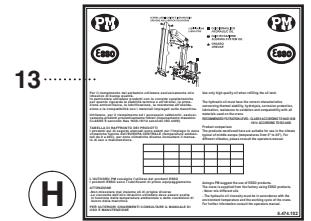
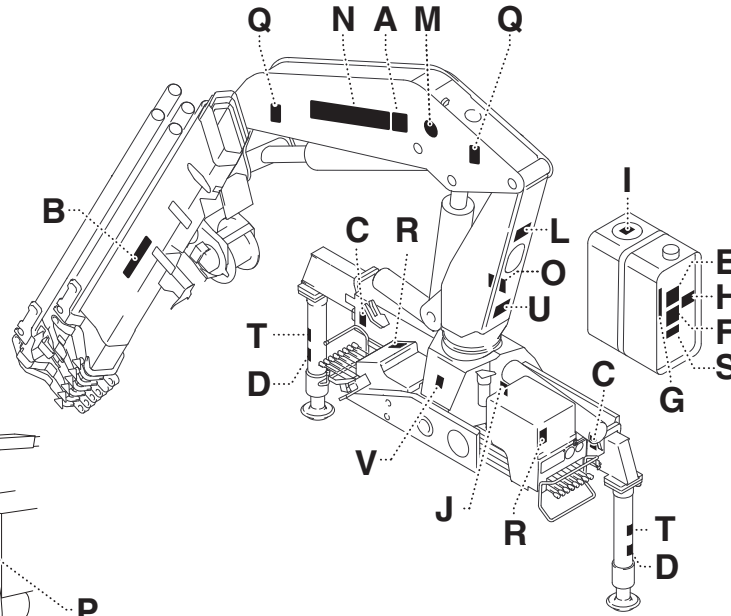
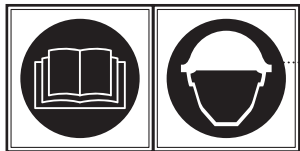
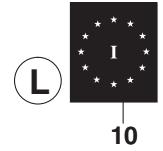
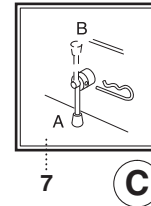
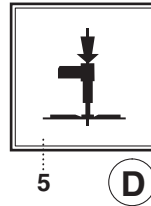
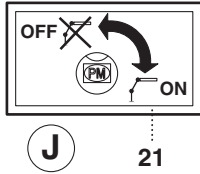

PM 23 P LC

matr. G107.0005

TAV. GO.05.01

POS.	N° CODICE	Q.	DESCRIZIONE	DESIGNATION	BENENNUNG	DESCRIPTION	DENOMINACIONES
■	289953	1	KIT TARGHETTA	KIT AUTOCOLLANT	SCHILDSATZ	DECAL KIT	KIT ETIQUETA
○	289954	1	KIT TARGHETTA	KIT AUTOCOLLANT	SCHILDSATZ	DECAL KIT	KIT ETIQUETA
✖	289907	1	KIT TARGHETTA	KIT AUTOCOLLANT	SCHILDSATZ	DECAL KIT	KIT ETIQUETA
◆	280877	1	KIT TARGHETTA (23022 P LC)	KIT AUTOCOLLANT	SCHILDSATZ	DECAL KIT	KIT ETIQUETA
*	280878	1	KIT TARGHETTA (23023 P LC)	KIT AUTOCOLLANT	SCHILDSATZ	DECAL KIT	KIT ETIQUETA
▲	280879	1	KIT TARGHETTA (23024 P LC)	KIT AUTOCOLLANT	SCHILDSATZ	DECAL KIT	KIT ETIQUETA
□	280880	1	KIT TARGHETTA (23025 P LC)	KIT AUTOCOLLANT	SCHILDSATZ	DECAL KIT	KIT ETIQUETA
▶	280881	1	KIT TARGHETTA (23026 P LC)	KIT AUTOCOLLANT	SCHILDSATZ	DECAL KIT	KIT ETIQUETA
▼	280882	1	KIT TARGHETTA (23027 P LC)	KIT AUTOCOLLANT	SCHILDSATZ	DECAL KIT	KIT ETIQUETA

Nota: ordinare solo i kit targhetta

Nota: ne commander que les kits plaque

Anmerkung: nur den Satz Schilder bestellen

Note: order only plate kits

Nota: ordenar sólo los kit tarjeta

SUPPLEMENTI - ACCESSORI

OPTIONALS - ACCESSORIES

ZUSATZ - AUSTATTUNG

OPTIONS - ACCESSOIRES

OPCIONES - ACCESORIOS



1° PROLUNGA MECCANICA (21023 - 23023 P)

- * 1ère rallonge mécanique
- * 1. mechanische Verlängerung
- * 1st mechanical extension
- * 1era prolonga mecánica

TAV. ST.01.01

matr. G107.0005

21
23 P

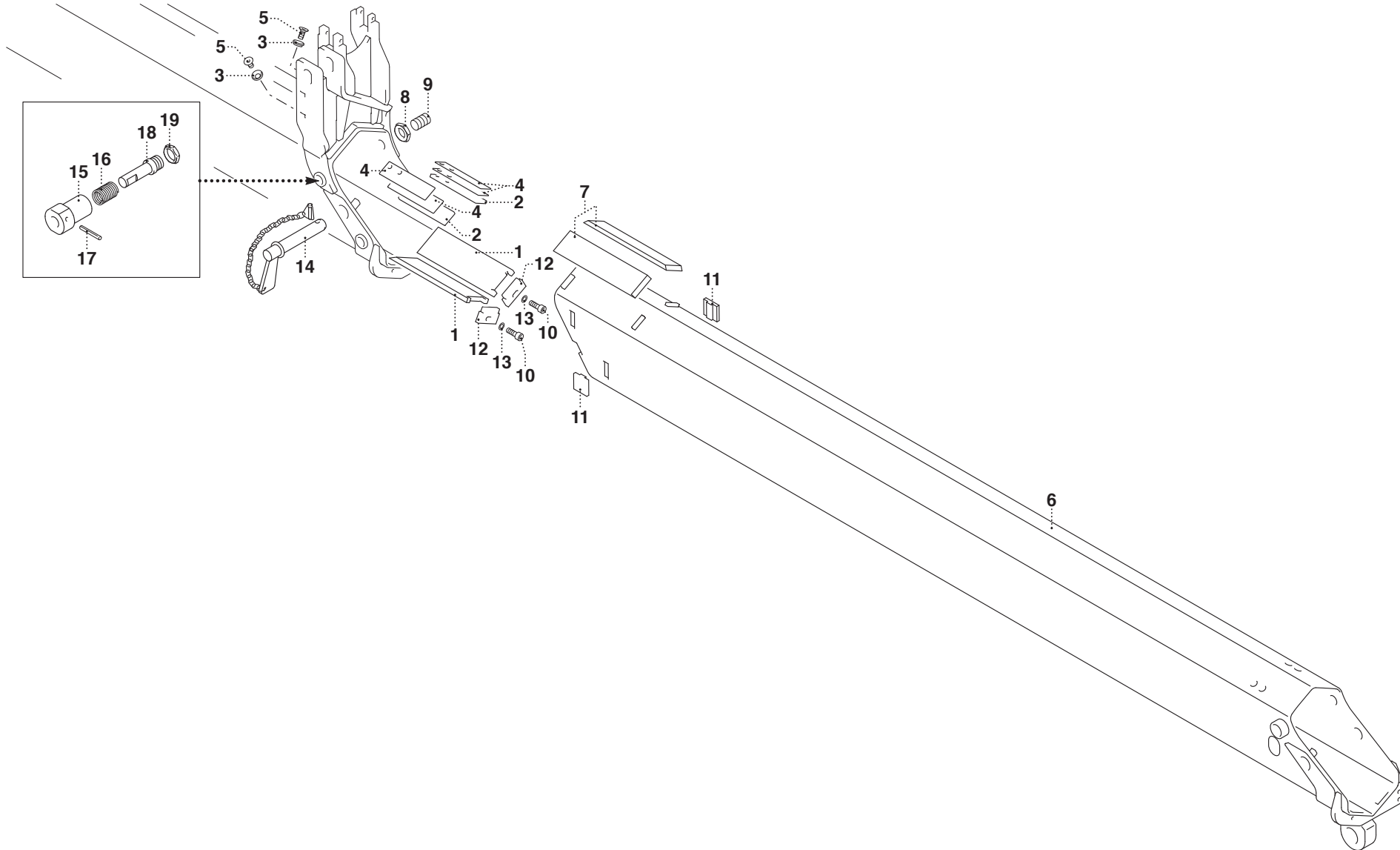

PM 21023 - PM 23023 P**matr. G107.0005****TAV. ST.01.01**

POS.	N° CODICE	Q.	DESCRIZIONE	DESIGNATION	BENENNUNG	DESCRIPTION	DENOMINACIONES
1	373992	2	PATTINO	PATIN	GLEITBLOCK	SLIDING BLOCK	PATIN
2	373927	2	PATTINO	PATIN	GLEITBLOCK	SLIDING BLOCK	PATIN
3	140026	4	BORCHIA	BOSSETTE	WARZE	STUD	BULLON
4	308992	4	SPESSORE	EPAISSEUR	DICKE	THICKNESS	ESPEJOR
5	497909	4	VITE	VIS	SCHRAUBE	SCREW	TORNILLO
6	142615	1	BRACCIO	BRAS	ARM	ARM	BRAZO
7	373993	2	PATTINO	PATIN	GLEITBLOCK	SLIDING BLOCK	PATIN
8	191213	3	DADO	ECROU	MUTTER	NUT	TUERCA
9	498156	3	VITE	VIS	SCHRAUBE	SCREW	TORNILLO
10	497383	2	VITE	VIS	SCHRAUBE	SCREW	TORNILLO
11	373924	4	PATTINO	PATIN	GLEITBLOCK	SLIDING BLOCK	PATIN
12	208281	2	FERMO	ARRET	VERSTELLVORRICHTUNG	LOCK	TOPE
13	417004	2	RONDELLA	RONDELLE	SCHEIBE	WASHER	ARANDELA
14	379348	1	PERNO	AXE	BOLZEN	PIN	PERNO
15	136903	1	BOCCOLA	DOUILLE	BUCHSE	BUSHING	CASQUILLO
16	349110	1	MOLLA	RESSORT	FEDER	SPRING	MUELLE
17	455200	1	SPINA	GOUPILLE	STIFT	PIN	PASADOR
18	380597	1	PERNO	AXE	BOLZEN	PIN	PERNO
19	191085	1	DADO	ECROU	MUTTER	NUT	TUERCA



1° PROLUNGA MECCANICA (21024 - 23024 P) - 2° PROLUNGA MECCANICA (21023 - 23023 P)

- * 1ère rallonge mécanique - 2ème rallonge mécanique
- * 1. mechanische Verlängerung - 2. mechanische Verlängerung
- * 1st mechanical extension - 2nd mechanical extension
- * 1era prolonga mecánica - 2da prolonga mecánica

TAV. ST.02.01

matr. G107.0005

21
23 P

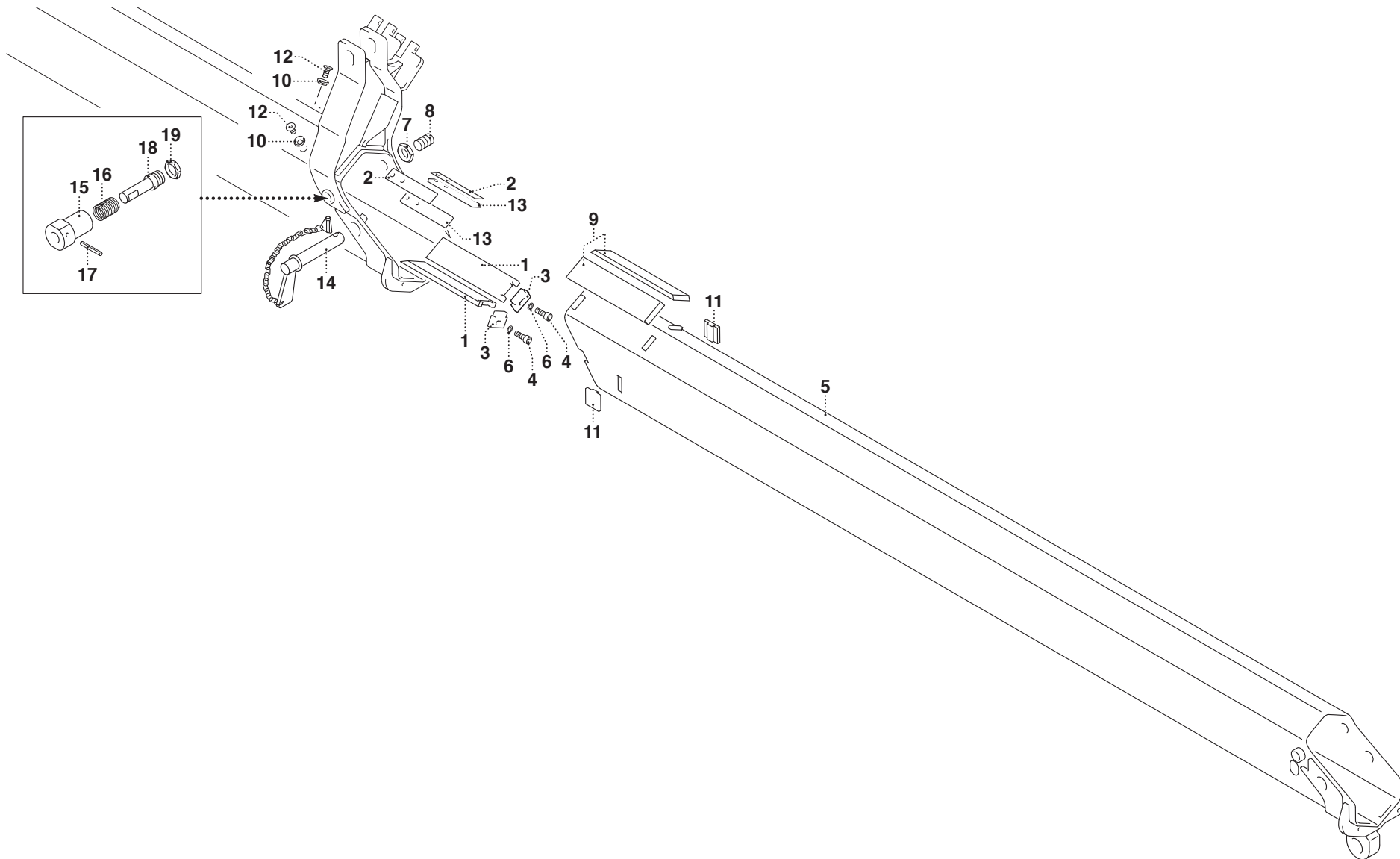

PM 21023-24 - PM 23023-24 P**matr. G107.0005****TAV. ST.02.01**

POS.	N° CODICE	Q.	DESCRIZIONE	DESIGNATION	BENENNUNG	DESCRIPTION	DENOMINACIONES
1	373994	2	PATTINO	PATIN	GLEITBLOCK	SLIDING BLOCK	PATIN
2	304384	2	SPESSORE	EPAISSEUR	DICKE	THICKNESS	ESPEJOR
3	208282	2	FERMO	ARRET	VERSTELLVORRICHTUNG	LOCK	TOPE
4	497383	2	VITE	VIS	SCHRAUBE	SCREW	TORNILLO
5	142616	1	BRACCIO	BRAS	ARM	ARM	BRAZO
6	417004	2	RONDELLA	RONDELLE	SCHEIBE	WASHER	ARANDELA
7	191213	1	DADO	ECROU	MUTTER	NUT	TUERCA
8	498156	1	VITE	VIS	SCHRAUBE	SCREW	TORNILLO
9	373993	2	PATTINO	PATIN	GLEITBLOCK	SLIDING BLOCK	PATIN
10	140026	4	BORCHIA	BOSSETTE	WARZE	STUD	BULLON
11	373924	2	PATTINO	PATIN	GLEITBLOCK	SLIDING BLOCK	PATIN
12	497909	4	VITE	VIS	SCHRAUBE	SCREW	TORNILLO
13	373837	2	PATTINO	PATIN	GLEITBLOCK	SLIDING BLOCK	PATIN
14	379324	1	PERNO	AXE	BOLZEN	PIN	PERNO
15	136903	1	BOCCOLA	DOUILLE	BUCHSE	BUSHING	CASQUILLO
16	349110	1	MOLLA	RESSORT	FEDER	SPRING	MUELLE
17	455200	1	SPINA	GOUPILLE	STIFT	PIN	PASADOR
18	380597	1	PERNO	AXE	BOLZEN	PIN	PERNO
19	191085	1	DADO	ECROU	MUTTER	NUT	TUERCA



1° PROLUNGA MECCANICA (21025 - 23025 P) - 2° PROLUNGA MECCANICA (21024 - 23024 P) - 3° PROLUNGA MECCANICA (21023 - 23023 P)

- * 1ère rallonge mécanique - 2ème rallonge mécanique - 3ème rallonge mécanique
- * 1. mechanische Verlängerung - 2. mechanische Verlängerung - 3. mechanische Verlängerung
- * 1st mechanical extension - 2nd mechanical extension - 3rd mechanical extension
- * 1era prolonga mecánica - 2da prolonga mecánica - 3era prolonga mecánica

TAV. ST.03.01

matr. G107.0005

21
23 P

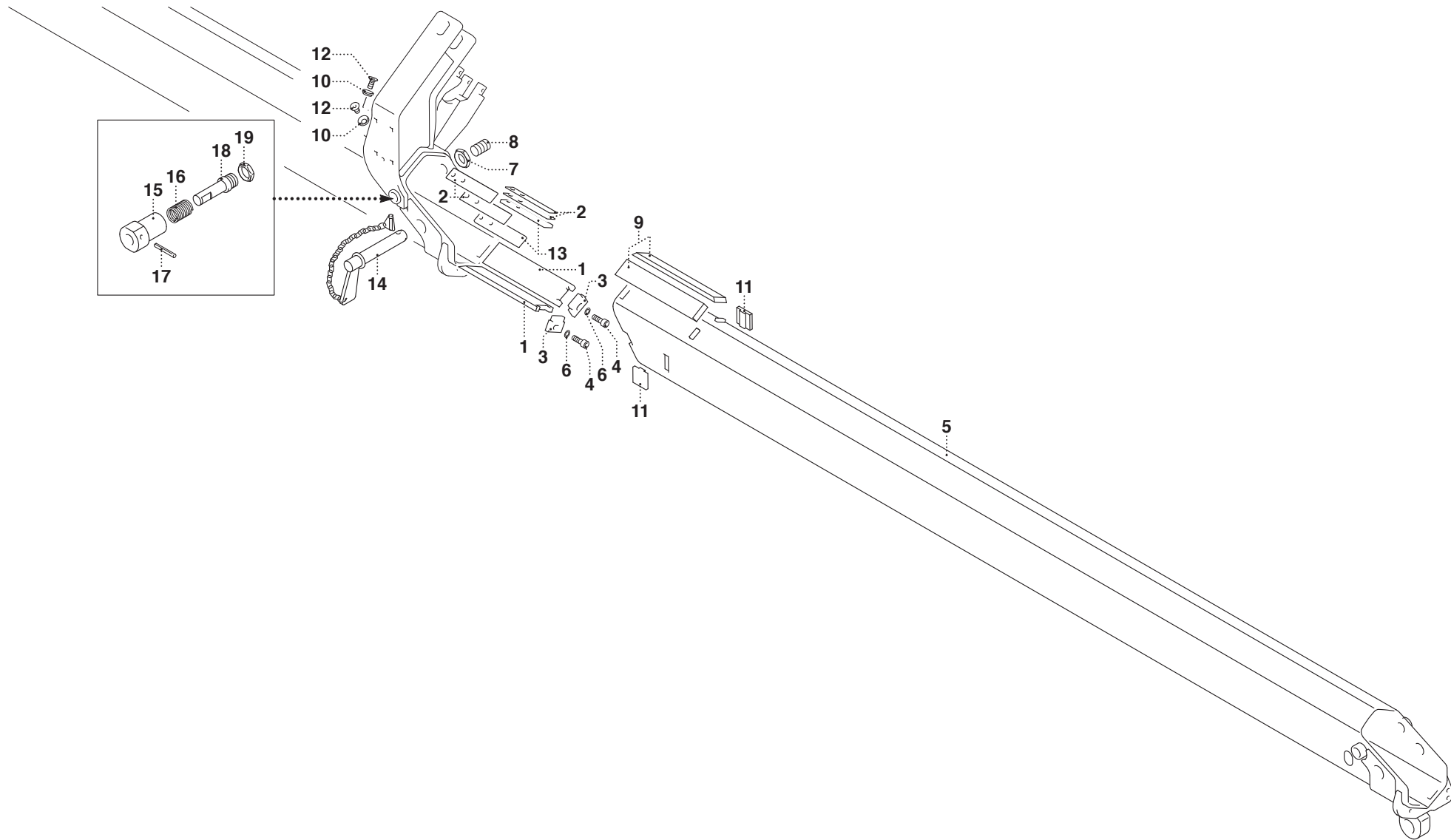

PM 21023-24-25 - PM 23023-24-25 P**matr. G107.0005****TAV. ST.03.01**

POS.	N° CODICE	Q.	DESCRIZIONE	DESIGNATION	BENENNUNG	DESCRIPTION	DENOMINACIONES
1	373994	2	PATTINO	PATIN	GLEITBLOCK	SLIDING BLOCK	PATIN
2	304384	4	SPESSORE	EPAISSEUR	DICKE	THICKNESS	ESPEJOR
3	208282	2	FERMO	ARRET	VERSTELLVORRICHTUNG	LOCK	TOPE
4	497383	2	VITE	VIS	SCHRAUBE	SCREW	TORNILLO
5	142617	1	BRACCIO	BRAS	ARM	ARM	BRAZO
6	417004	2	RONDELLA	RONDELLE	SCHEIBE	WASHER	ARANDELA
7	191213	1	DADO	ECROU	MUTTER	NUT	TUERCA
8	498156	1	VITE	VIS	SCHRAUBE	SCREW	TORNILLO
9	373995	2	PATTINO	PATIN	GLEITBLOCK	SLIDING BLOCK	PATIN
10	140026	4	BORCHIA	BOSSETTE	WARZE	STUD	BULLON
11	373924	2	PATTINO	PATIN	GLEITBLOCK	SLIDING BLOCK	PATIN
12	497909	4	VITE	VIS	SCHRAUBE	SCREW	TORNILLO
13	373837	2	PATTINO	PATIN	GLEITBLOCK	SLIDING BLOCK	PATIN
14	379325	1	PERNO	AXE	BOLZEN	PIN	PERNO
15	136903	1	BOCCOLA	DOUILLE	BUCHSE	BUSHING	CASQUILLO
16	349110	1	MOLLA	RESSORT	FEDER	SPRING	MUELLE
17	455200	1	SPINA	GOUPILLE	STIFT	PIN	PASADOR
18	380597	1	PERNO	AXE	BOLZEN	PIN	PERNO
19	191085	1	DADO	ECROU	MUTTER	NUT	TUERCA



1° PROLUNGA MECCANICA (21026 - 23026 P) - 2° PROLUNGA MECCANICA (21025 - 23025 P)

- * 1ère rallonge mécanique - 2ème rallonge mécanique
- * 1. mechanische Verlängerung - 2. mechanische Verlängerung
- * 1st mechanical extension - 2nd mechanical extension
- * 1era prolonga mecánica - 2da prolonga mecánica

TAV. ST.04.01

matr. G107.0005

21
23 P

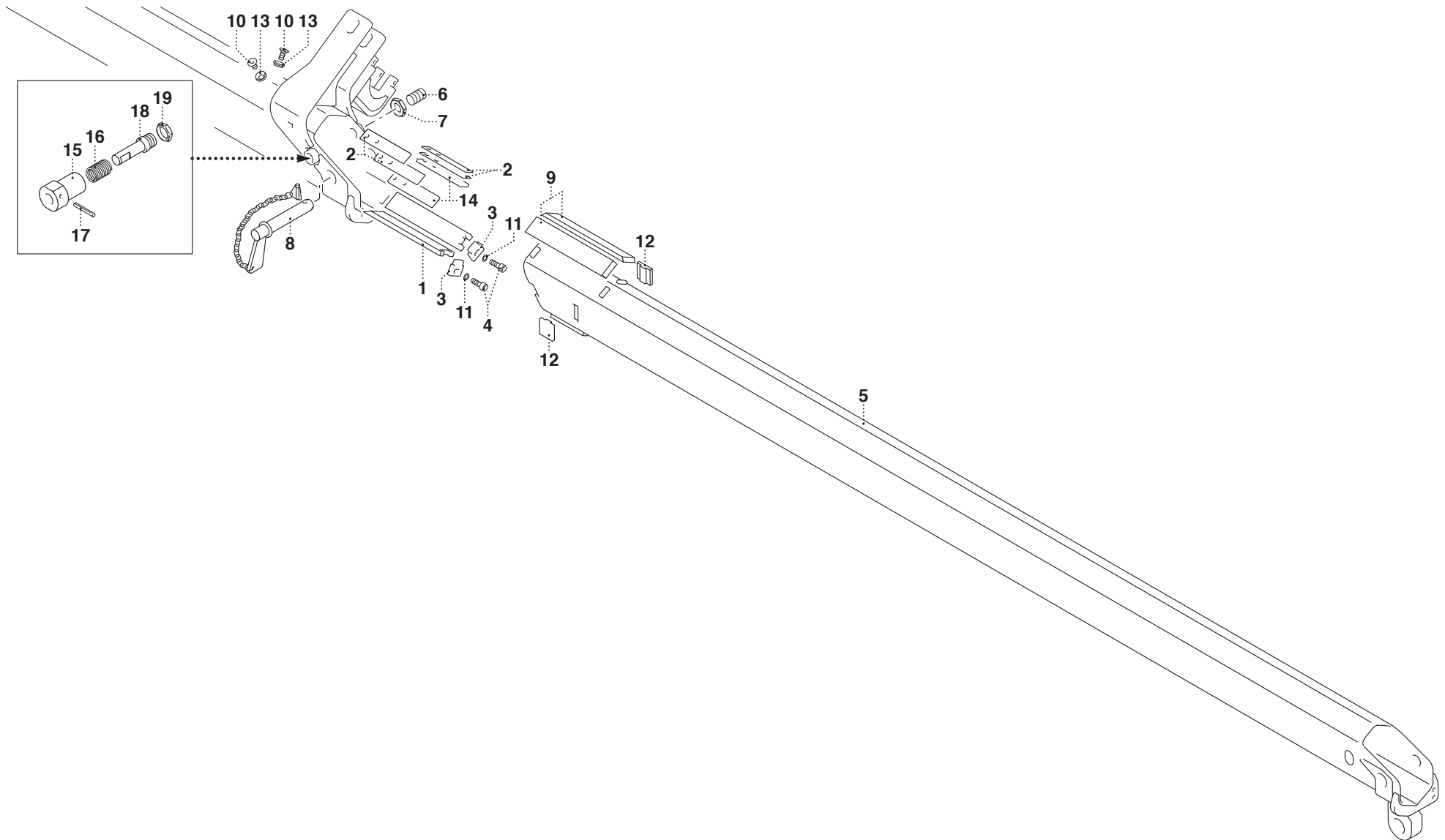

PM 21025-26 - PM 23025-26 P

matr. G107.0005

TAV. ST.04.01

POS.	N° CODICE	Q.	DESCRIZIONE	DESIGNATION	BENENNUNG	DESCRIPTION	DENOMINACIONES
1	373996	2	PATTINO	PATIN	GLEITBLOCK	SLIDING BLOCK	PATIN
2	304384	4	SPESSORE	EPAISSEUR	DICKE	THICKNESS	ESPEJOR
3	208283	2	FERMO	ARRET	VERSTELLVORRICHTUNG	LOCK	TOPE
4	497383	2	VITE	VIS	SCHRAUBE	SCREW	TORNILLO
5	142618	1	BRACCIO	BRAS	ARM	ARM	BRAZO
6	498156	1	VITE	VIS	SCHRAUBE	SCREW	TORNILLO
7	191213	1	DADO	ECROU	MUTTER	NUT	TUERCA
8	379202	1	PERNO	AXE	BOLZEN	PIN	PERNO
9	373995	2	PATTINO	PATIN	GLEITBLOCK	SLIDING BLOCK	PATIN
10	497909	4	VITE	VIS	SCHRAUBE	SCREW	TORNILLO
11	417004	2	RONDELLA	RONDELLE	SCHEIBE	WASHER	ARANDELA
12	373924	2	PATTINO	PATIN	GLEITBLOCK	SLIDING BLOCK	PATIN
13	140026	4	BORCHIA	BOSSETTE	WARZE	STUD	BULLON
14	373837	2	PATTINO	PATIN	GLEITBLOCK	SLIDING BLOCK	PATIN
15	136903	1	BOCCOLA	DOUILLE	BUCHSE	BUSHING	CASQUILLO
16	349110	1	MOLLA	RESSORT	FEDER	SPRING	MUELLE
17	455200	1	SPINA	GOUPILLE	STIFT	PIN	PASADOR
18	380597	1	PERNO	AXE	BOLZEN	PIN	PERNO
19	191085	1	DADO	ECROU	MUTTER	NUT	TUERCA



LIMITATORE DI MOMENTO - HYDROCONTROL (21)

* Limiteur de moment - HYDROCONTROL
* Momentbegrenzer - HYDROCONTROL
* Moment control device - HYDROCONTROL
* Sistema limitador de momento - HYDROCONTROL

TAV. SU.01.01 1/2

matr. G107.0005

21
23 P

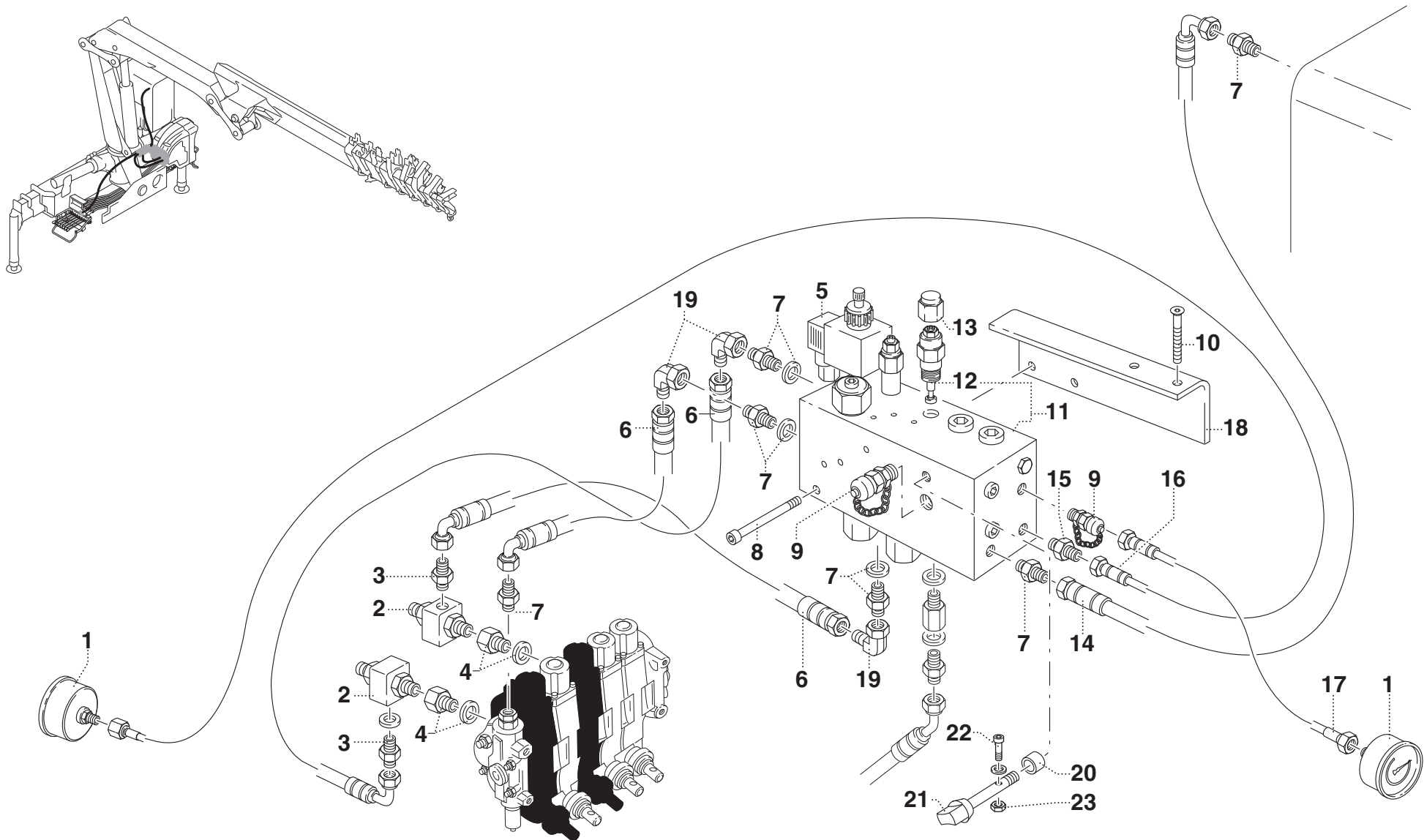

PM 21**matr. G107.0005****TAV. SU.01.01 1/2**

POS.	N° CODICE	Q.	DESCRIZIONE	DESIGNATION	BENENNUNG	DESCRIPTION	DENOMINACIONES
1	335008	2	MANOMETRO	MANOMETRE	DRUCKMESSER	GAUGE	MANOMETRO
2	239010	2	RACCORDO	RACCORD	ANSCHLUSS	FITTING	RACOR
3	409665	2	RACCORDO	RACCORD	ANSCHLUSS	FITTING	RACOR
4	164115	2	COLONNETTA	COLONNETTE	SCHRAUBBOLZEN	STUD BOLT	PERNO FILETEADO
5	204072	1	ELETTROVALVOLA	ELECTROVANNE	ELEKTROVENTIL	ELECTROVALVE	ELECTRO-VALVULA
6	485964	3	TUBO FLESSIBILE	TUYAU FLEXIBLE	SCHLAUCH	FLEXIBLE HOSE	TUBO FLEXIBLE
7	409664	6	RACCORDO	RACCORD	ANSCHLUSS	FITTING	RACOR
8	498084	2	VITE	VIS	SCHRAUBE	SCREW	TORNILLO
9	124009	1	INNESTO RAPIDO	CONNECTION RAPIDE	SCHNELLKUPPLUNG	FAST COUPLING	CONEXION RAPIDA
10	497908	2	VITE	VIS	SCHRAUBE	SCREW	TORNILLO
11	495532	1	VALVOLA	SOUPAPE	VENTIL	VALVE	VALVULA
12	495163	1	VALVOLA	SOUPAPE	VENTIL	VALVE	VALVULA
13	471277	1	TAPPO	BOUCHON	VERSCHLUSSDECKEL	PLUG	TAPON
14	486781	1	TUBO FLESSIBILE	TUYAU FLEXIBLE	SCHLAUCH	FLEXIBLE HOSE	TUBO FLEXIBLE
15	409675	2	RACCORDO	RACCORD	ANSCHLUSS	FITTING	RACOR
16	486629	1	TUBO FLESSIBILE	TUYAU FLEXIBLE	SCHLAUCH	FLEXIBLE HOSE	TUBO FLEXIBLE
17	486697	1	TUBO FLESSIBILE	TUYAU FLEXIBLE	SCHLAUCH	FLEXIBLE HOSE	TUBO FLEXIBLE
18	466512	1	SUPPORTO	SUPPORT	TRÄGER	SUPPORT	SOPORTE
19	410080	3	RACCORDO	RACCORD	ANSCHLUSS	FITTING	RACOR
20	395588	1	BOCCOLA	DOUILLE	BUCHSE	BUSHING	CASQUILLO
21	120749	1	LEVA	LEVIER	HEBEL	LEVER	PALANCA
22	497405	1	VITE	VIS	SCHRAUBE	SCREW	TORNILLO
23	191178	1	DADO	ECROU	MUTTER	NUT	TUERCA



LIMITATORE DI MOMENTO - HYDROCONTROL (21)

* Limiteur de moment - HYDROCONTROL
* Momentbegrenzer - HYDROCONTROL
* Moment control device - HYDROCONTROL
* Sistema limitador de momento - HYDROCONTROL

TAV. SU.01.01 2/2

matr. G107.0005

21
23 P

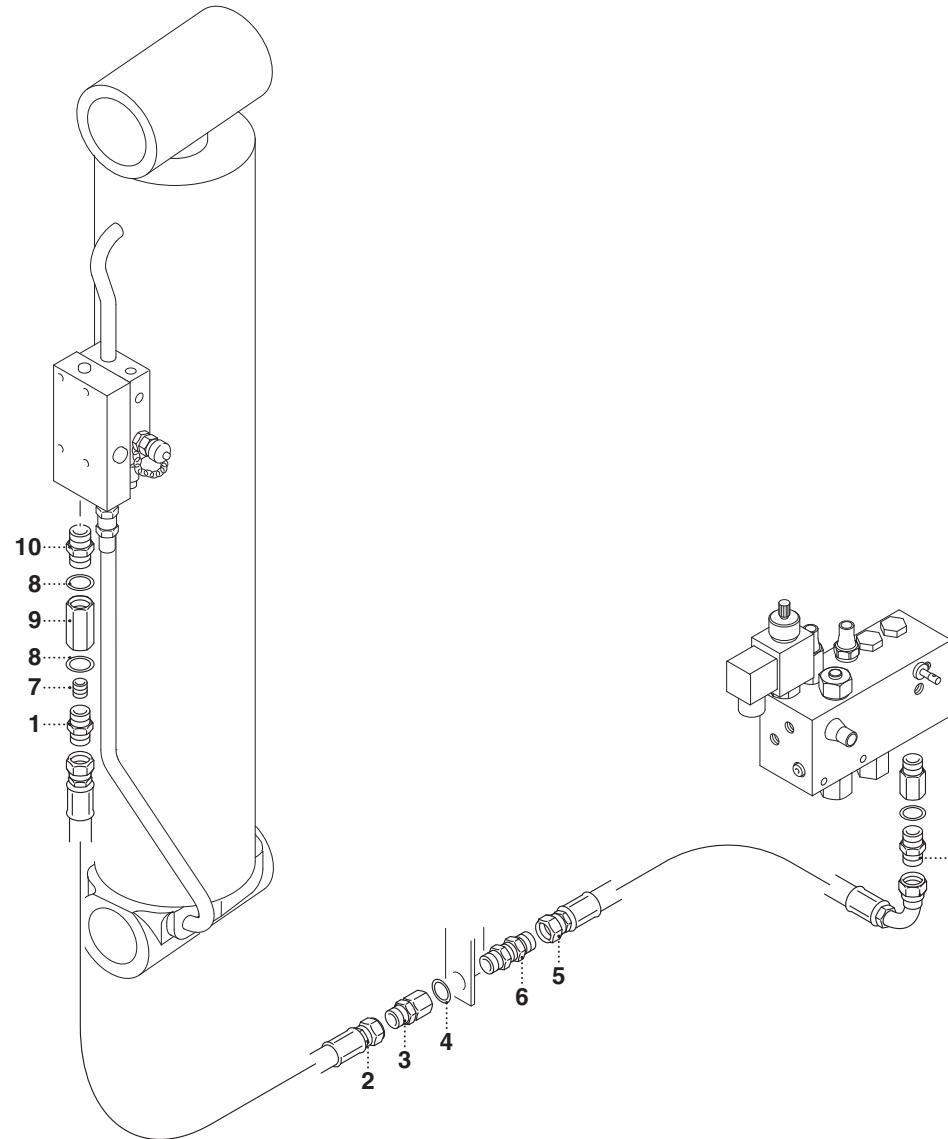
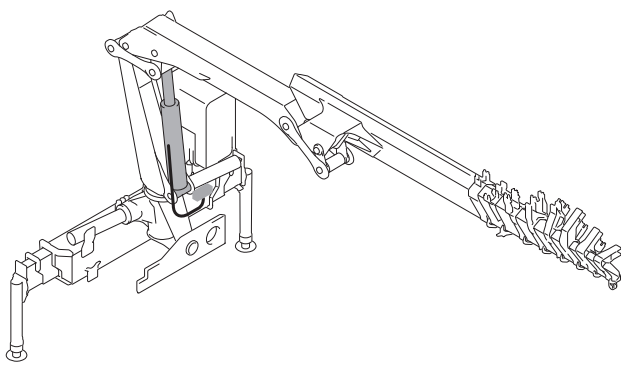



LIMITATORE DI MOMENTO - DANFOSS (21)

* Limiteur de moment - DANFOSS
* Momentbegrenzer - DANFOSS
* Moment control device - DANFOSS
* Sistema limitador de momento - DANFOSS

TAV. SU.01.02 1/2

matr. G107.0005

21
23 P

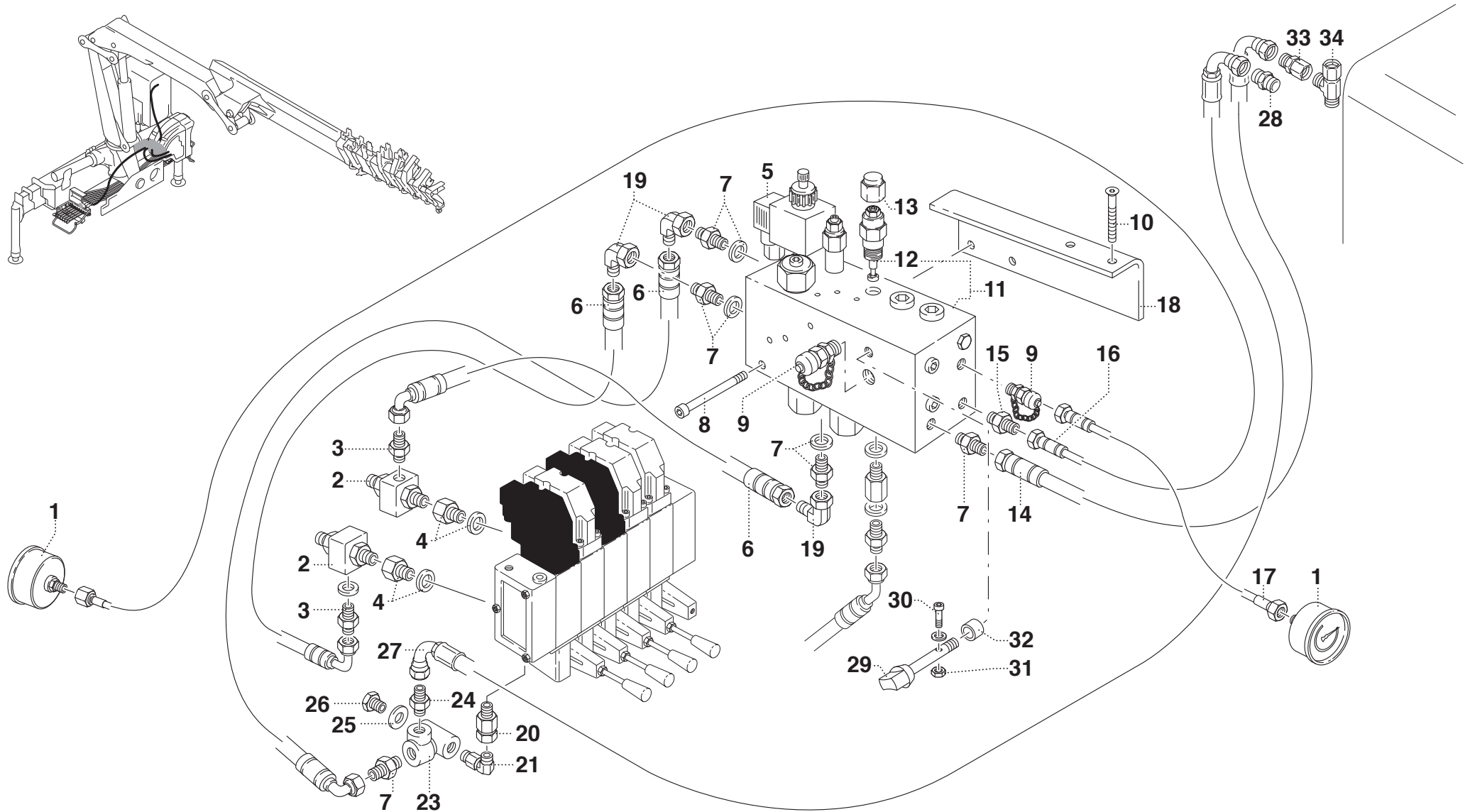

PM 21**matr. G107.0005****TAV. SU.01.02 1/2**

POS.	N° CODICE	Q.	DESCRIZIONE	DESIGNATION	BENENNUNG	DESCRIPTION	DENOMINACIONES
1	335008	2	MANOMETRO	MANOMETRE	DRUCKMESSER	GAUGE	MANOMETRO
2	239010	2	RACCORDO	RACCORD	ANSCHLUSS	FITTING	RACOR
3	409665	2	RACCORDO	RACCORD	ANSCHLUSS	FITTING	RACOR
4	164115	2	COLONNETTA	COLONNETTE	SCHRAUBBOLZEN	STUD BOLT	PERNO FILETEADO
5	204072	1	ELETTROVALVOLA	ELECTROVANNE	ELEKTROVENTIL	ELECTROVALVE	ELECTRO-VALVULA
6	485964	3	TUBO FLESSIBILE	TUYAU FLEXIBLE	SCHLAUCH	FLEXIBLE HOSE	TUBO FLEXIBLE
7	409664	5	RACCORDO	RACCORD	ANSCHLUSS	FITTING	RACOR
8	498084	2	VITE	VIS	SCHRAUBE	SCREW	TORNILLO
9	124009	1	INNESTO RAPIDO	CONNECTION RAPIDE	SCHNELLKUPPLUNG	FAST COUPLING	CONEXION RAPIDA
10	497908	2	VITE	VIS	SCHRAUBE	SCREW	TORNILLO
11	495532	1	VALVOLA	SOUPAPE	VENTIL	VALVE	VALVULA
12	495163	1	VALVOLA	SOUPAPE	VENTIL	VALVE	VALVULA
13	471277	1	TAPPO	BOUCHON	VERSCHLUSSDECKEL	PLUG	TAPON
14	486781	1	TUBO FLESSIBILE	TUYAU FLEXIBLE	SCHLAUCH	FLEXIBLE HOSE	TUBO FLEXIBLE
15	409675	2	RACCORDO	RACCORD	ANSCHLUSS	FITTING	RACOR
16	486629	1	TUBO FLESSIBILE	TUYAU FLEXIBLE	SCHLAUCH	FLEXIBLE HOSE	TUBO FLEXIBLE
17	486697	1	TUBO FLESSIBILE	TUYAU FLEXIBLE	SCHLAUCH	FLEXIBLE HOSE	TUBO FLEXIBLE
18	466512	1	SUPPORTO	SUPPORT	TRÄGER	SUPPORT	SOPORTE
19	410080	3	RACCORDO	RACCORD	ANSCHLUSS	FITTING	RACOR
20	409057	1	RACCORDO	RACCORD	ANSCHLUSS	FITTING	RACOR
21	409601	1	RACCORDO	RACCORD	ANSCHLUSS	FITTING	RACOR
22	494343	1	CARCASSA	CARCASSE	GEHÄUSE	CASING	ARMAZON
23	494095	1	VALVOLA	SOUPAPE	VENTIL	VALVE	VALVULA
24	409866	1	RACCORDO	RACCORD	ANSCHLUSS	FITTING	RACOR
25	417094	1	RONDELLA	RONDELLE	SCHEIBE	WASHER	ARANDELA
26	417024	1	TAPPO	BOUCHON	VERSCHLUSSDECKEL	PLUG	TAPON



LIMITATORE DI MOMENTO - DANFOSS (21)

* Limiteur de moment - DANFOSS
* Momentbegrenzer - DANFOSS
* Moment control device - DANFOSS
* Sistema limitador de momento - DANFOSS

TAV. SU.01.02 1/2

matr. G107.0005

21
23 P

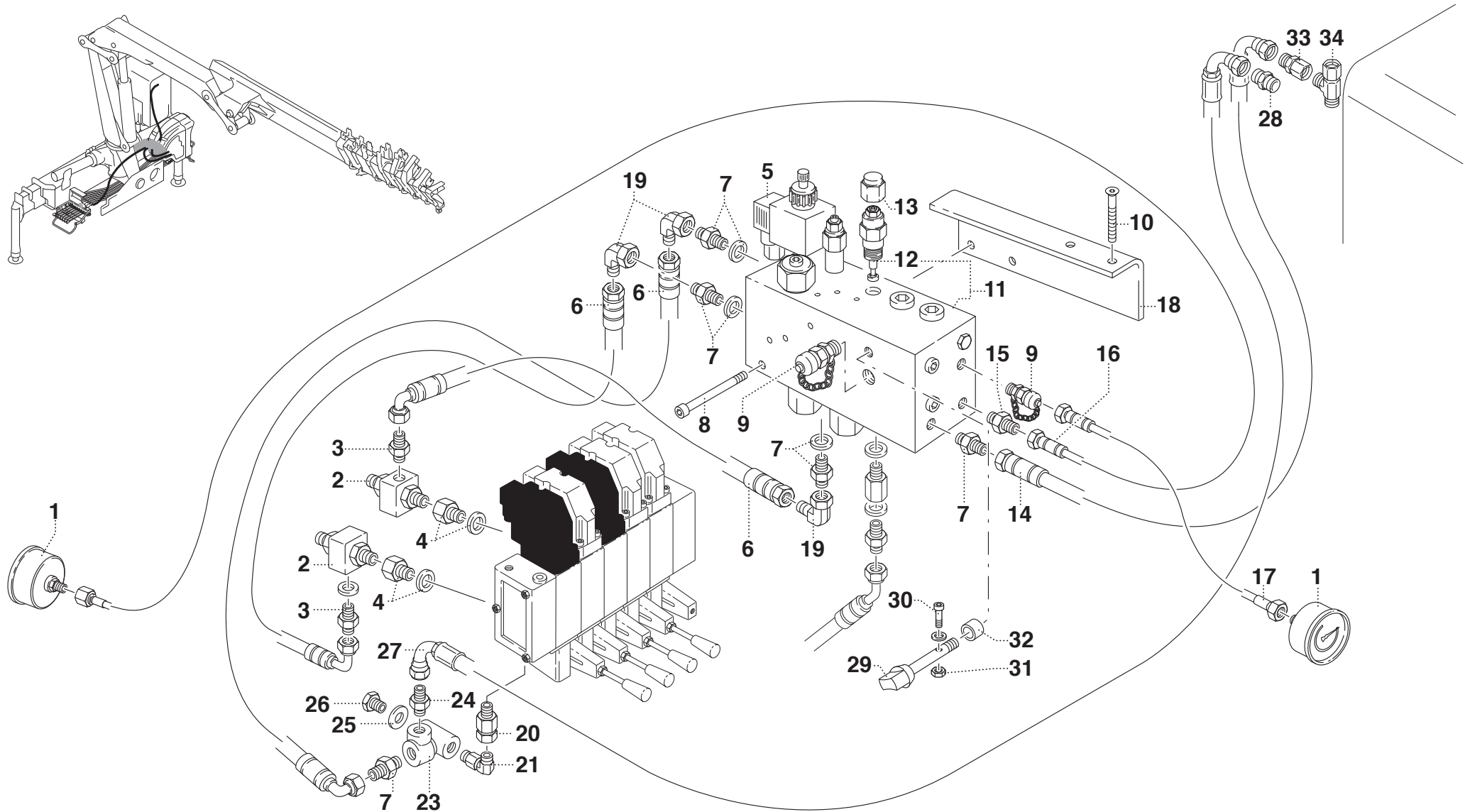



LIMITATORE DI MOMENTO - DANFOSS (21)

- * Limiteur de moment - DANFOSS
- * Momentbegrenzer - DANFOSS
- * Moment control device - DANFOSS
- * Sistema limitador de momento - DANFOSS

TAV. SU.01.02 2/2

matr. G107.0005

21
23 P

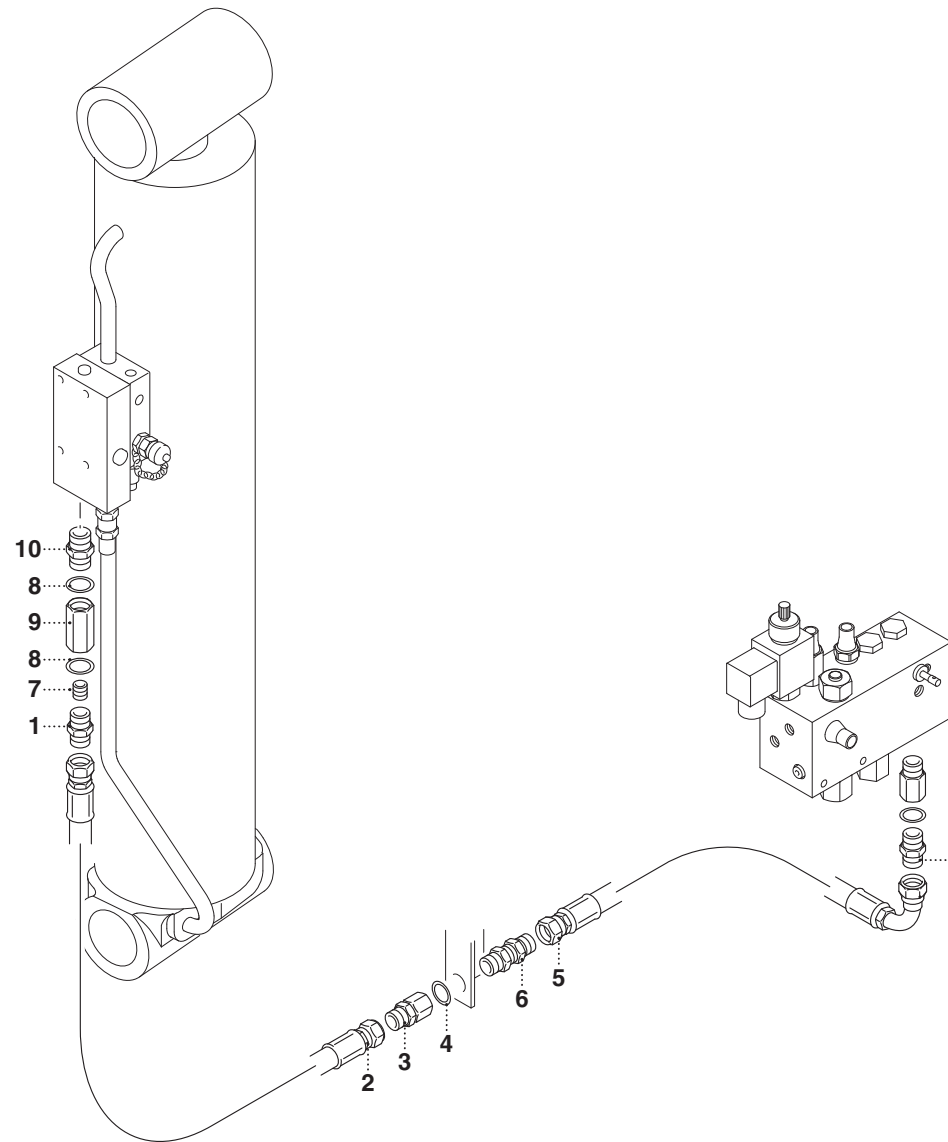
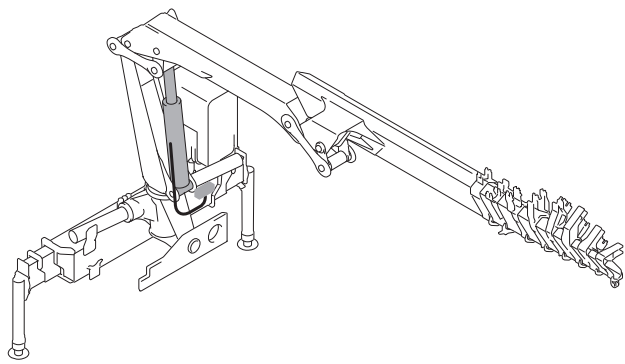



COMPL. IMPIANTO SENZA LIMITATORE (HYDROCONTROL - RADIOCOMANDO) (21)

- * Compl. installation sans limiteur (HYDROCONTROL - Radiocommande)
- * Anlagebetätigung ohne Begrenzer (HYDROCONTROL - Fernsteuerung)
- * System completion without limiting device (HYDROCONTROL - Radio control)
- * Complet. instalación sin limitador (HYDROCONTROL - Radiomando)

TAV. SU.02.01

matr. G107.0005

21
23 P

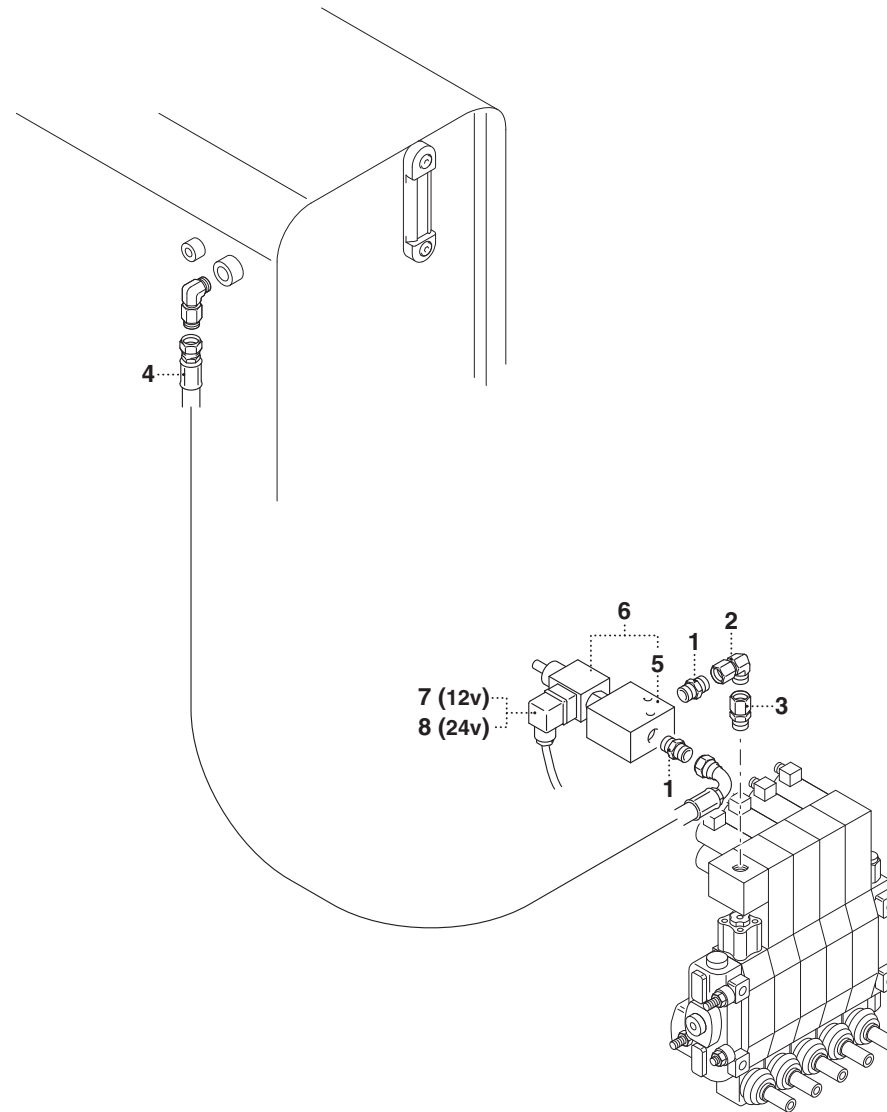



COMANDO 1° ATTIVAZIONE - AVVOLGITUBO

- * *Commande 1ère activation - enrouleur*
- * *1. Betätigungssteuerung - Schlauchwickler*
- * *1st activation control - hose reel*
- * *Mando 1era activación con enrollador*

TAV. SV.01.01 1/2

matr. G107.0005

21
23 P

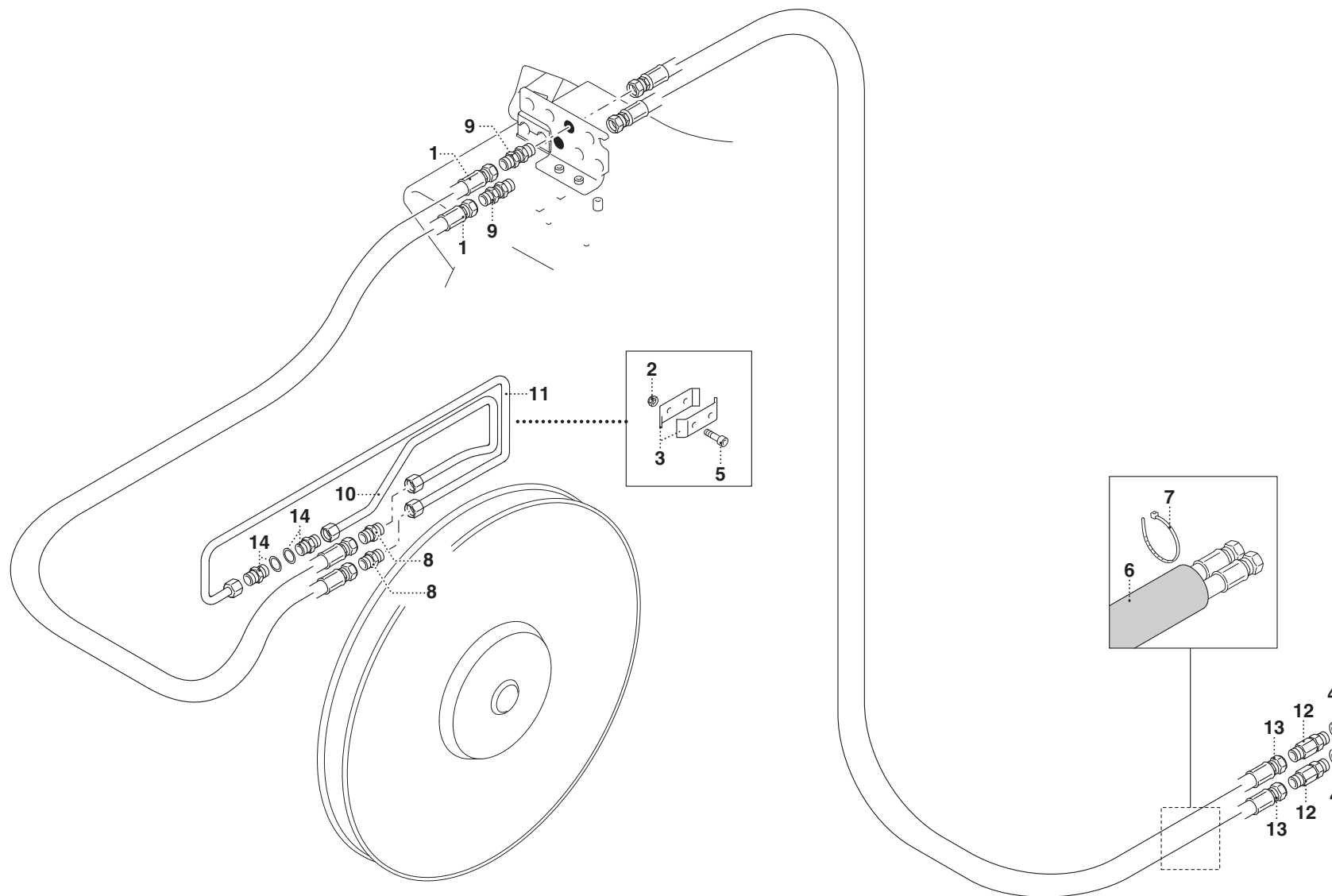

PM 21 - PM 23 P

matr. G107.0005

TAV. SV.01.01 1/2

POS.	N° CODICE	Q.	DESCRIZIONE	DESIGNATION	BENENNUNG	DESCRIPTION	DENOMINACIONES
1	485847	2	TUBO FLESSIBILE	TUYAU FLEXIBLE	SCHLAUCH	FLEXIBLE HOSE	TUBO FLEXIBLE
2	191162	2	DADO	ECROU	MUTTER	NUT	TUERCA
3	466518	2	SUPPORTO	SUPPORT	TRÄGER	SUPPORT	SOPORTE
4	417092	2	RONDELLA	RONDELLE	SCHEIBE	WASHER	ARANDELA
5	497123	2	VITE	VIS	SCHRAUBE	SCREW	TORNILLO
6	276081	1	GUAINA	GAINÉ	MANTEL	SHEATH	VAINA
7	207064	2	FASCETTA	COLLIER	HALTEBAND	CLAMP	ABRAZADERA
8	409930	2	RACCORDO	RACCORD	ANSCHLUSS	FITTING	RACOR
9	410164	2	RACCORDO	RACCORD	ANSCHLUSS	FITTING	RACOR
10	460217	1	TUBO RIGIDO	TUYAU RIGIDE	ROHR	PIPE	TUBO RIGIDO
11	460216	1	TUBO RIGIDO	TUYAU RIGIDE	ROHR	PIPE	TUBO RIGIDO
12	239268	2	RACCORDO	RACCORD	ANSCHLUSS	FITTING	RACOR
13	482535	2	TUBO FLESSIBILE	TUYAU FLEXIBLE	SCHLAUCH	FLEXIBLE HOSE	TUBO FLEXIBLE
14	409610	2	RACCORDO	RACCORD	ANSCHLUSS	FITTING	RACOR



COMPL. COMANDO 1° ATTIVAZIONE - AVVOLGITUBO

* Compl. commande 1ère activation - enrouleur
* Steuerung 1. Aktivierung - Ergänzung - Schlauchwickler
* 1st activation control compl. - hose reel
* Complet. mando 1° activación - enrollador

TAV. SV.01.01 2/2

matr. G107.0005

21
23 P

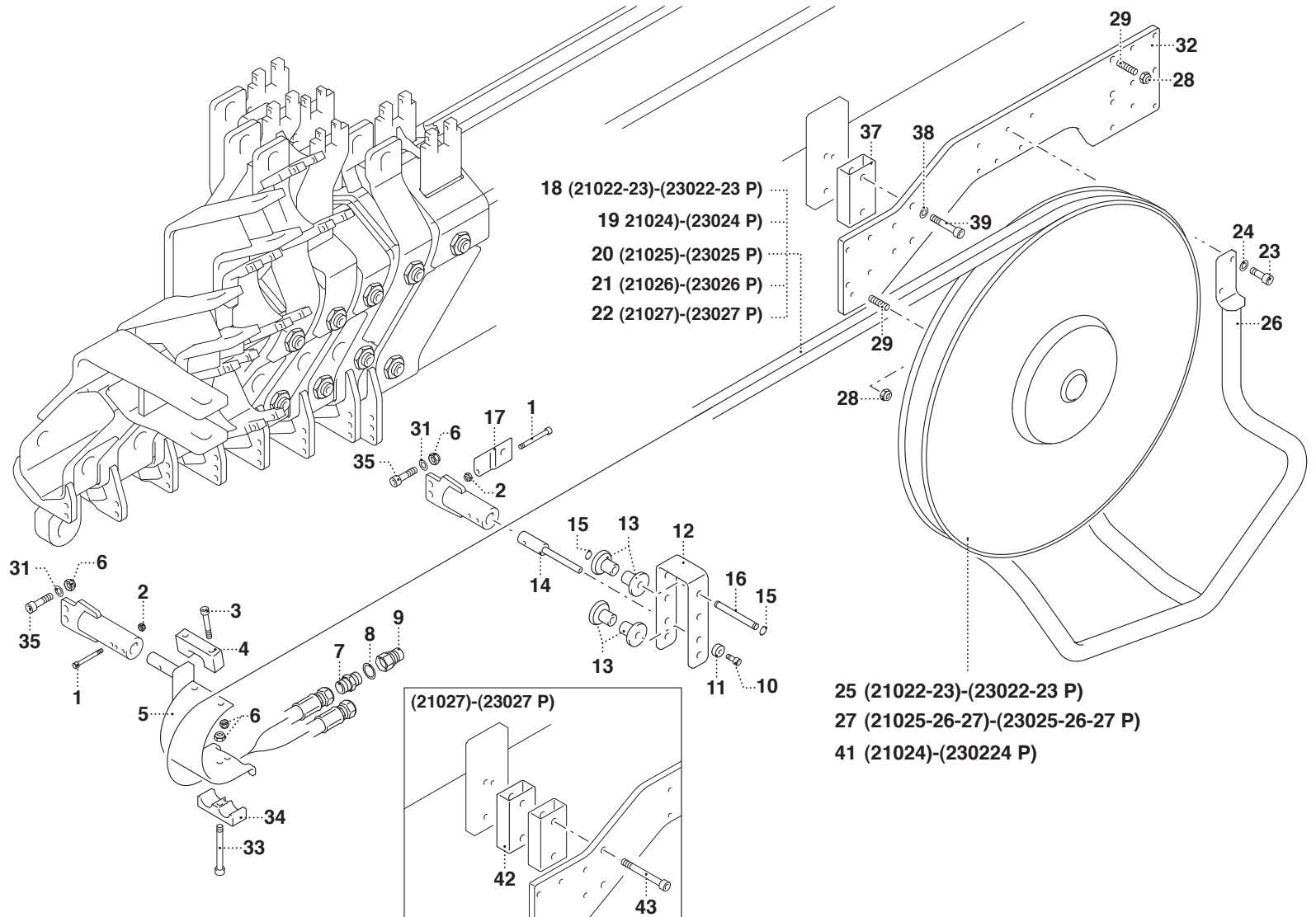
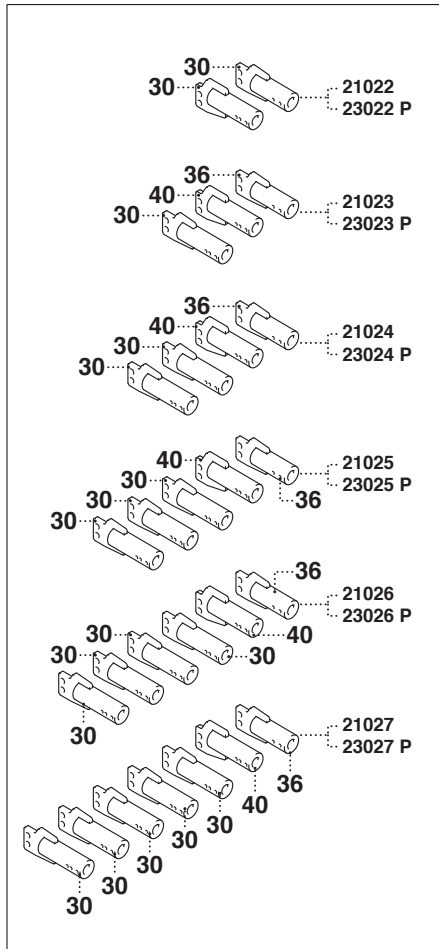

PM 21 - PM 23 P

matr. G107.0005

TAV. SV.01.01 2/2

POS.	N° CODICE	Q.	DESCRIZIONE	DESIGNATION	BENENNUNG	DESCRIPTION	DENOMINACIONES
1	497391	2	VITE	VIS	SCHRAUBE	SCREW	TORNILLO
2	191046	2	DADO	ECROU	MUTTER	NUT	TUERCA
3	497138	2	VITE	VIS	SCHRAUBE	SCREW	TORNILLO
4	208191	1	FERMO	ARRET	VERSTELLVORRICHTUNG	LOCK	TOPE
5	466461	1	SUPPORTO	SUPPORT	TRÄGER	SUPPORT	SOPORTE
6	191168	7	DADO	ECROU	MUTTER	NUT	TUERCA
7	409678	2	RACCORDO	RACCORD	ANSCHLUSS	FITTING	RACOR
8	417092	2	RONDELLA	RONDELLE	SCHEIBE	WASHER	ARANDELA
9	124001	2	INNESTO RAPIDO	CONNECTION RAPIDE	SCHNELLKUPPLUNG	FAST COUPLING	CONEXION RAPIDA
10	498072	1	VITE	VIS	SCHRAUBE	SCREW	TORNILLO
11	136516	1	DISTANZIALE	ENTRETOISE	DISTANZSTÜCK	SPACER	DISTANCIADOR
12	466460	5	SUPPORTO	SUPPORT	TRÄGER	SUPPORT	SOPORTE
13	429054	6	RULLO	GALET	ROLLE	ROLLER	RODILLO
14	380183	1	PERNO	AXE	BOLZEN	PIN	PERNO
15	109001	2	ANELLO ELASTICO	JOINT D'ARRET	SPRENGRING	SPRING RING	ANILLO ELASTICO
16	380157	1	PERNO	AXE	BOLZEN	PIN	PERNO
17	208194	1	FERMO	ARRET	VERSTELLVORRICHTUNG	LOCK	TOPE
18	486447	1	TUBO FLESSIBILE	TUYAU FLEXIBLE	SCHLAUCH	FLEXIBLE HOSE	TUBO FLEXIBLE
19	486446	1	TUBO FLESSIBILE	TUYAU FLEXIBLE	SCHLAUCH	FLEXIBLE HOSE	TUBO FLEXIBLE
20	486746	1	TUBO FLESSIBILE	TUYAU FLEXIBLE	SCHLAUCH	FLEXIBLE HOSE	TUBO FLEXIBLE
21	486807	1	TUBO FLESSIBILE	TUYAU FLEXIBLE	SCHLAUCH	FLEXIBLE HOSE	TUBO FLEXIBLE
22	486862	1	TUBO FLESSIBILE	TUYAU FLEXIBLE	SCHLAUCH	FLEXIBLE HOSE	TUBO FLEXIBLE
23	497131	4	VITE	VIS	SCHRAUBE	SCREW	TORNILLO
24	417025	4	RONDELLA	RONDELLE	SCHEIBE	WASHER	ARANDELA
25	469041	1	AVVOLGITUBO	ENROULEUR	SCHLAUCHWICKLER	HOSE REEL	ENROLLADOR
26	403240	1	PROTEZIONE	PROTECTION	SCHUTZ	GUARD	PROTECCION



COMPL. COMANDO 1° ATTIVAZIONE - AVVOLGITUBO

* Compl. commande 1ère activation - enrouleur
* Steuerung 1. Aktivierung - Ergänzung - Schlauchwickler
* 1st activation control compl. - hose reel
* Complet. mando 1° activación - enrollador

TAV. SV.01.01 2/2

matr. G107.0005

21
23 P

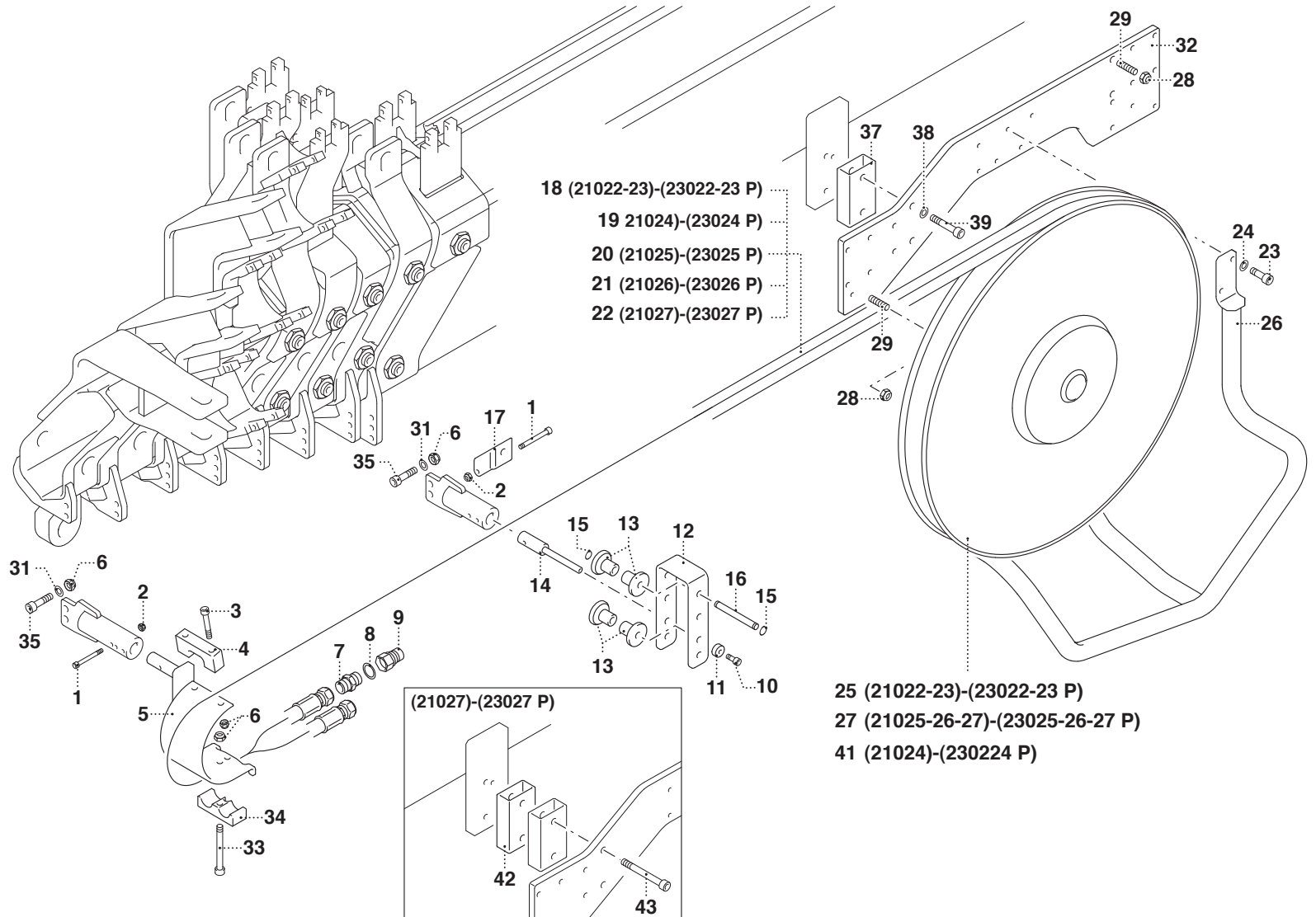
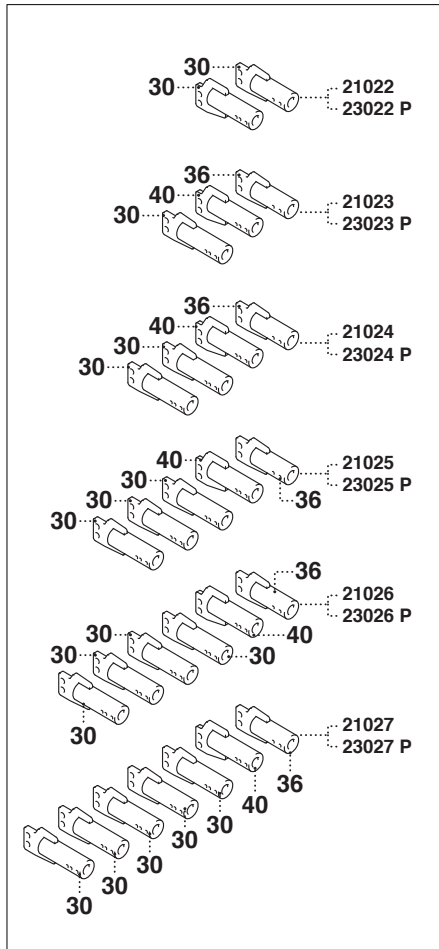

PM 21 - PM 23 P

matr. G107.0005

TAV. SV.01.01 2/2

POS.	N° CODICE	Q.	DESCRIZIONE	DESIGNATION	BENENNUNG	DESCRIPTION	DENOMINACIONES
27	469058	1	AVVOLGITUBO	ENROULEUR	SCHLAUCHWICKLER	HOSE REEL	ENROLLADOR
28	191045	4	DADO	ECROU	MUTTER	NUT	TUERCA
29	497353	4	VITE	VIS	SCHRAUBE	SCREW	TORNILLO
30	466698	1	SUPPORTO	SUPPORT	TRÄGER	SUPPORT	SOPORTE
31	417004	7	RONDELLA	RONDELLE	SCHEIBE	WASHER	ARANDELA
32	466474	1	SUPPORTO	SUPPORT	TRÄGER	SUPPORT	SOPORTE
33	497136	1	VITE	VIS	SCHRAUBE	SCREW	TORNILLO
34	353113	1	MORSETTO	ETAU	KLEMME	CLAMP	PRENSOR
35	497134	4	VITE	VIS	SCHRAUBE	SCREW	TORNILLO
36	466699	1	SUPPORTO	SUPPORT	TRÄGER	SUPPORT	SOPORTE
37	313178	2	SUPPORTO	SUPPORT	TRÄGER	SUPPORT	SOPORTE
38	417026	4	RONDELLA	RONDELLE	SCHEIBE	WASHER	ARANDELA
39	497151	4	VITE	VIS	SCHRAUBE	SCREW	TORNILLO
40	466697	1	SUPPORTO	SUPPORT	TRÄGER	SUPPORT	SOPORTE
41	469044	1	AVVOLGITUBO	ENROULEUR	SCHLAUCHWICKLER	HOSE REEL	ENROLLADOR
42	313178	2	SUPPORTO	SUPPORT	TRÄGER	SUPPORT	SOPORTE
43	497154	4	VITE	VIS	SCHRAUBE	SCREW	TORNILLO



COMANDO 2° ATTIVAZIONE - AVVOLGITUBO

- * *Commande 1ère activation - enrouleur*
- * *1. Betätigungssteuerung - Schlauchwickler*
- * *1st activation control - hose reel*
- * *Mando 1era activación con enrollador*

TAV. SV.02.01 1/2

matr. G107.0005

21
23 P

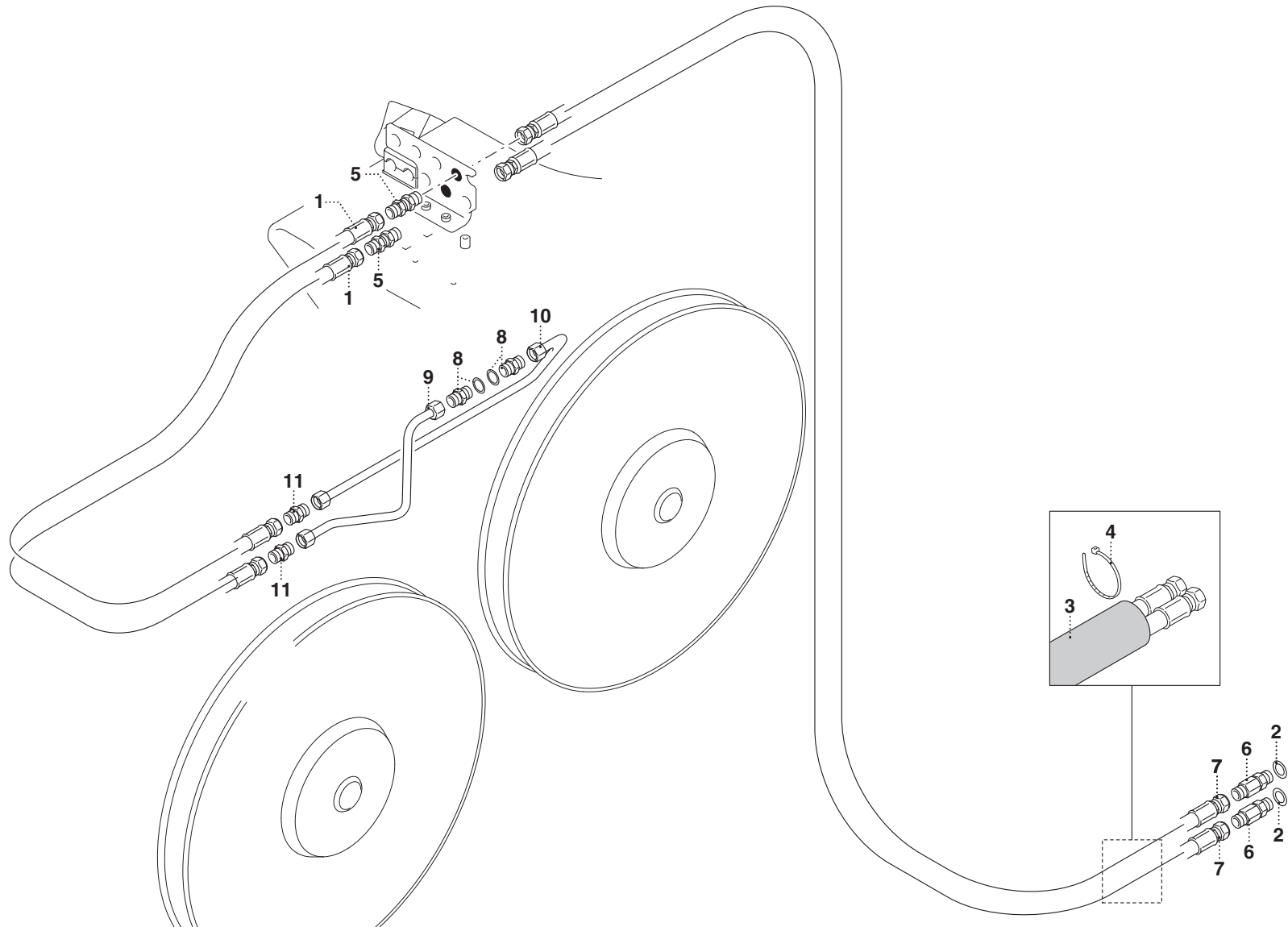



COMPL. COMANDO 2° ATTIVAZIONE - AVVOLGITUBO

* Compl. commande 2ème activation - enrouleur
* Steuerung 2. Aktivierung - Ergänzung - Schlauchwickler
* 2nd activation control compl. - hose reel
* Complet. mando 2° activación - enrollador

TAV. SV.02.01 2/2

matr. G107.0005

21
23 P

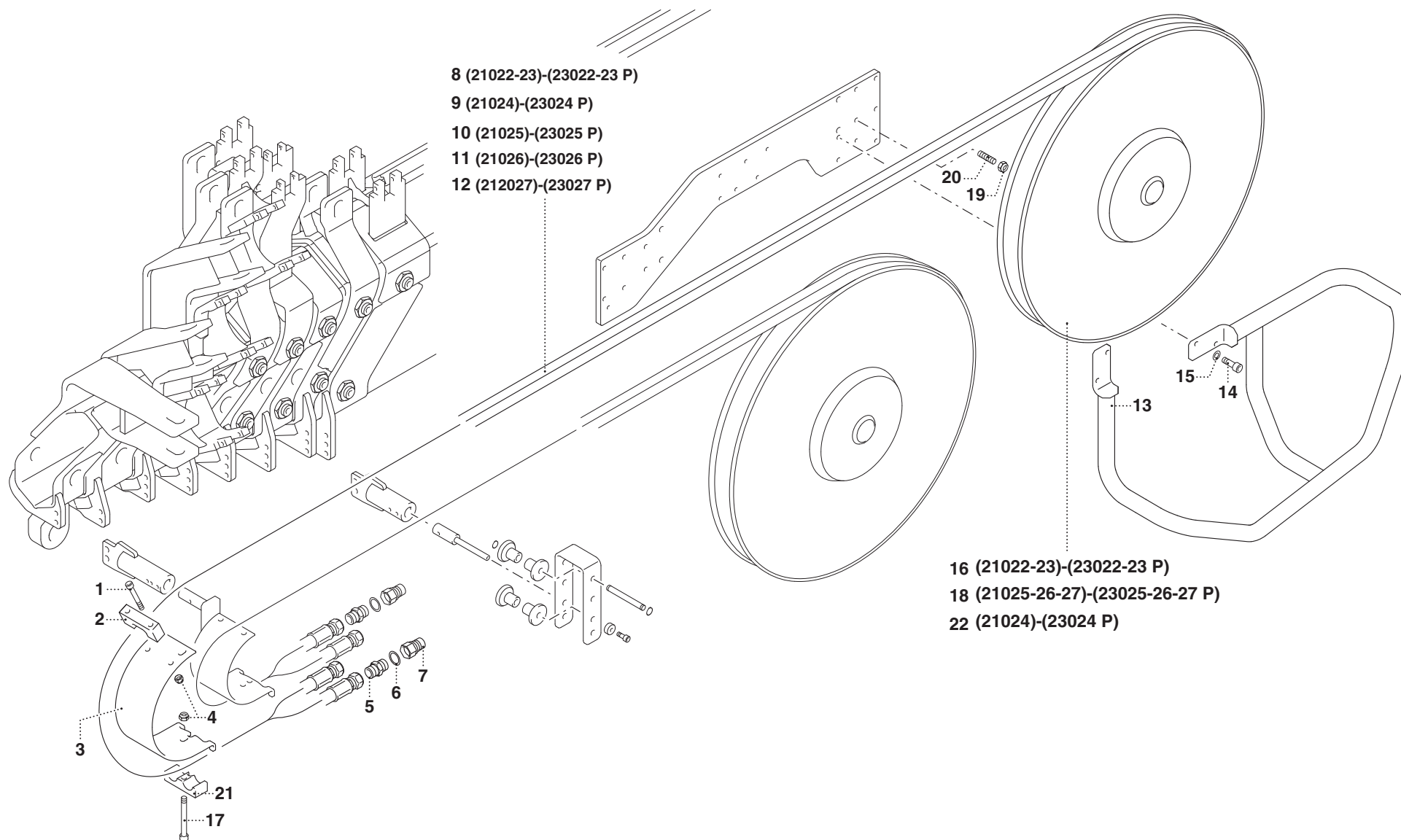

PM 21 - PM 23 P**matr. G107.0005****TAV. SV.02.01 2/2**

POS.	N° CODICE	Q.	DESCRIZIONE	DESIGNATION	BENENNUNG	DESCRIPTION	DENOMINACIONES
1	497138	4	VITE	VIS	SCHRAUBE	SCREW	TORNILLO
2	208191	2	FERMO	ARRET	VERSTELLVORRICHTUNG	LOCK	TOPE
3	208192	1	FERMO	ARRET	VERSTELLVORRICHTUNG	LOCK	TOPE
4	191090	4	DADO	ECROU	MUTTER	NUT	TUERCA
5	409678	2	RACCORDO	RACCORD	ANSCHLUSS	FITTING	RACOR
6	417092	2	RONDELLA	RONDELLE	SCHEIBE	WASHER	ARANDELA
7	124001	2	INNESTO RAPIDO	CONNECTION RAPIDE	SCHNELLKUPPLUNG	FAST COUPLING	CONEXION RAPIDA
8	486447	1	TUBO FLESSIBILE	TUYAU FLEXIBLE	SCHLAUCH	FLEXIBLE HOSE	TUBO FLEXIBLE
9	486446	1	TUBO FLESSIBILE	TUYAU FLEXIBLE	SCHLAUCH	FLEXIBLE HOSE	TUBO FLEXIBLE
10	486746	1	TUBO FLESSIBILE	TUYAU FLEXIBLE	SCHLAUCH	FLEXIBLE HOSE	TUBO FLEXIBLE
11	486807	1	TUBO FLESSIBILE	TUYAU FLEXIBLE	SCHLAUCH	FLEXIBLE HOSE	TUBO FLEXIBLE
12	486862	1	TUBO FLESSIBILE	TUYAU FLEXIBLE	SCHLAUCH	FLEXIBLE HOSE	TUBO FLEXIBLE
13	403239	1	PROTEZIONE	PROTECTION	SCHUTZ	GUARD	PROTECCION
14	497131	4	VITE	VIS	SCHRAUBE	SCREW	TORNILLO
15	417025	4	RONDELLA	RONDELLE	SCHEIBE	WASHER	ARANDELA
16	469041	1	AVVOLGITUBO	ENROULEUR	SCHLAUCHWICKLER	HOSE REEL	ENROLLADOR
17	498084	1	VITE	VIS	SCHRAUBE	SCREW	TORNILLO
18	469058	1	AVVOLGITUBO	ENROULEUR	SCHLAUCHWICKLER	HOSE REEL	ENROLLADOR
19	191092	4	DADO	ECROU	MUTTER	NUT	TUERCA
20	497353	4	VITE	VIS	SCHRAUBE	SCREW	TORNILLO
21	353113	1	MORSETTO	ETAU	KLEMME	CLAMP	PRENSOR
22	469044	1	AVVOLGITUBO	ENROULEUR	SCHLAUCHWICKLER	HOSE REEL	ENROLLADOR



COMPL. ATTIVAZIONE - RACCOGLITUBO (21023 - 23023 P)

* Compl. activation - serre-tubes
* Aktivierung - Ergänzung - Schlauchaufnahme
* Activation compl. - pipe holder
* Complet. activación - recogetubo

TAV. SV.03.01

matr. G107.0005

21
23 P

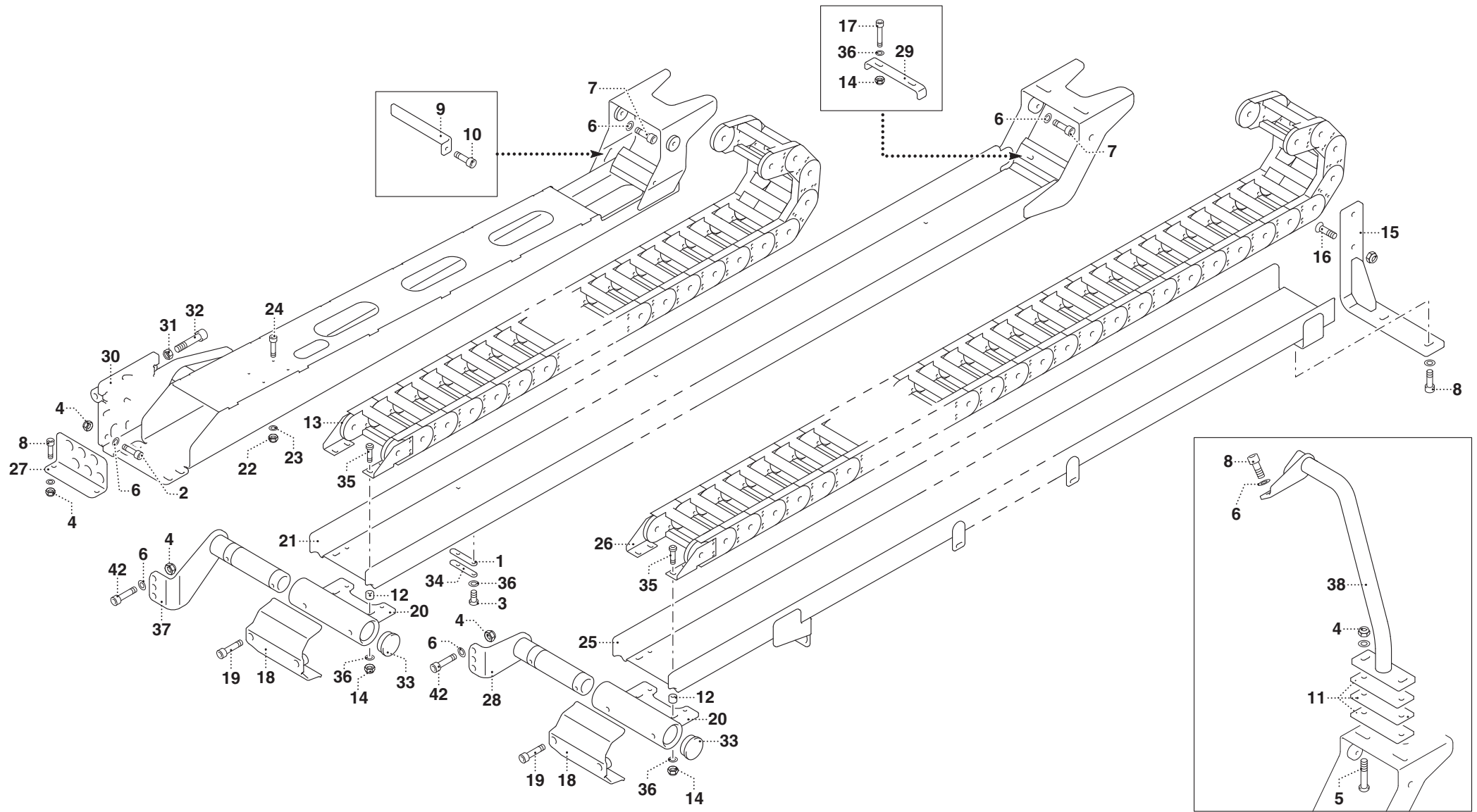

PM 21023 - PM 23023 P**matr. G107.0005****TAV. SV.03.01**

POS.	N° CODICE	Q.	DESCRIZIONE	DESIGNATION	BENENNUNG	DESCRIPTION	DENOMINACIONES
1	467566	6	SUPPORTO	SUPPORT	TRÄGER	SUPPORT	SOPORTE
2	497134	10	VITE	VIS	SCHRAUBE	SCREW	TORNILLO
3	497436	12	VITE	VIS	SCHRAUBE	SCREW	TORNILLO
4	191168	6	DADO	ECROU	MUTTER	NUT	TUERCA
5	497440	2	VITE	VIS	SCHRAUBE	SCREW	TORNILLO
6	417004	15	RONDELLA	RONDELLE	SCHEIBE	WASHER	ARANDELA
7	497383	4	VITE	VIS	SCHRAUBE	SCREW	TORNILLO
8	497131	7	VITE	VIS	SCHRAUBE	SCREW	TORNILLO
9	467565	1	SUPPORTO	SUPPORT	TRÄGER	SUPPORT	SOPORTE
10	497117	1	VITE	VIS	SCHRAUBE	SCREW	TORNILLO
11	314601	3	SUPPORTO	SUPPORT	TRÄGER	SUPPORT	SOPORTE
12	137392	8	BOCCOLA	DOUILLE	BUCHSE	BUSHING	CASQUILLO
13	151055	1	CATENA	CHAINE	KETTE	CHAIN	CADENA
14	191125	10	DADO	ECROU	MUTTER	NUT	TUERCA
15	467558	1	SUPPORTO	SUPPORT	TRÄGER	SUPPORT	SOPORTE
16	497208	2	VITE	VIS	SCHRAUBE	SCREW	TORNILLO
17	497123	2	VITE	VIS	SCHRAUBE	SCREW	TORNILLO
18	403254	2	PROTEZIONE	PROTECTION	SCHUTZ	GUARD	PROTECCION
19	497135	4	VITE	VIS	SCHRAUBE	SCREW	TORNILLO
20	120986	2	SUPPORTO	SUPPORT	TRÄGER	SUPPORT	SOPORTE
21	467552	1	SUPPORTO	SUPPORT	TRÄGER	SUPPORT	SOPORTE
22	191155	4	DADO	ECROU	MUTTER	NUT	TUERCA
23	417001	4	RONDELLA	RONDELLE	SCHEIBE	WASHER	ARANDELA
24	497835	4	VITE	VIS	SCHRAUBE	SCREW	TORNILLO
25	467554	1	SUPPORTO	SUPPORT	TRÄGER	SUPPORT	SOPORTE
26	151054	1	CATENA	CHAINE	KETTE	CHAIN	CADENA



COMPL. ATTIVAZIONE - RACCOGLITUBO (21023 - 23023 P)

* Compl. activation - serre-tubes
* Aktivierung - Ergänzung - Schlauchaufnahme
* Activation compl. - pipe holder
* Complet. activación - recogetubo

TAV. SV.03.01

matr. G107.0005

21
23 P

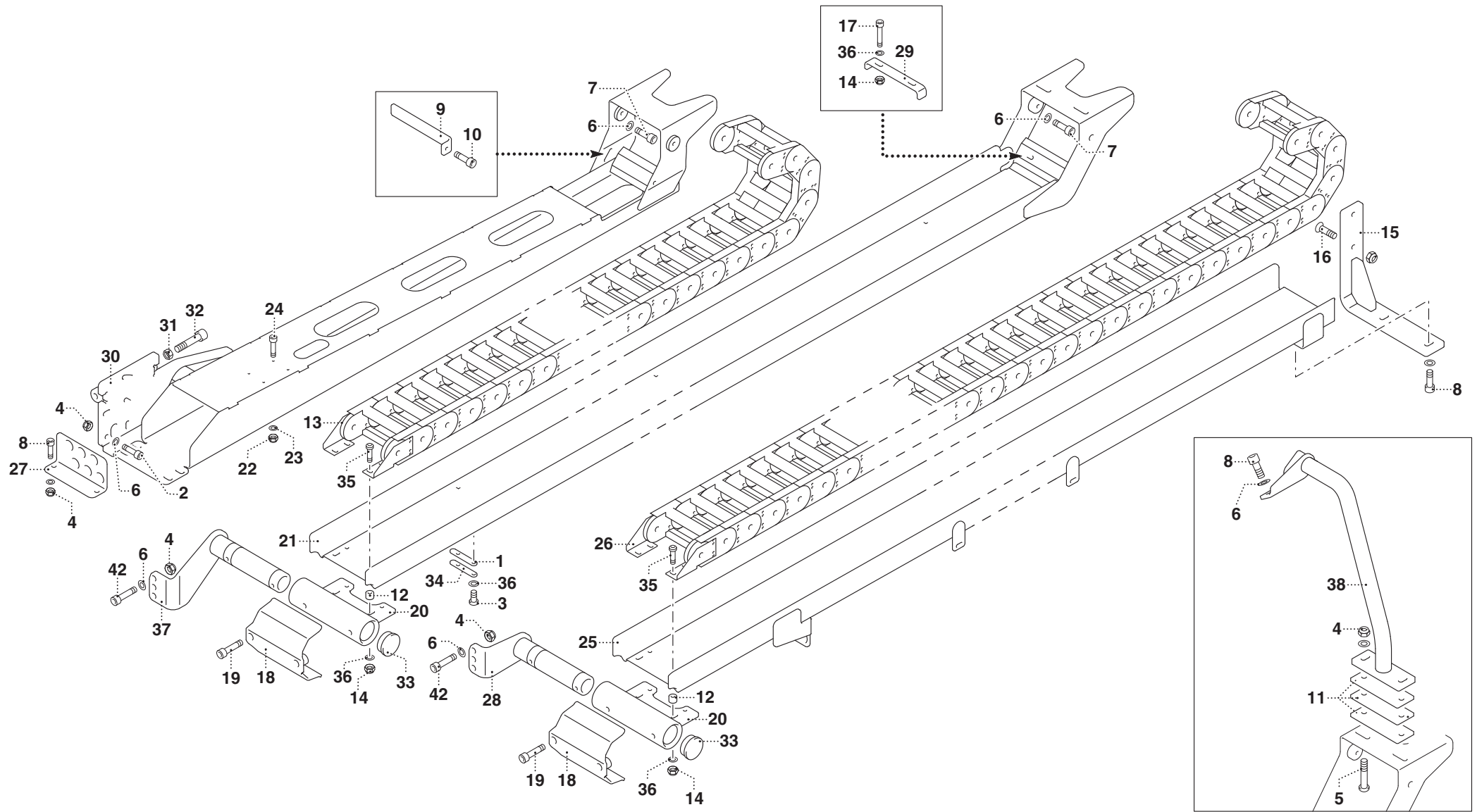

PM 21023 - PM 23023 P

matr. G107.0005

TAV. SV.03.01

POS.	N° CODICE	Q.	DESCRIZIONE	DESIGNATION	BENENNUNG	DESCRIPTION	DENOMINACIONES
27	467567	1	SUPPORTO	SUPPORT	TRÄGER	SUPPORT	SOPORTE
28	467555	1	SUPPORTO	SUPPORT	TRÄGER	SUPPORT	SOPORTE
29	467245	1	SUPPORTO	SUPPORT	TRÄGER	SUPPORT	SOPORTE
30	467551	1	SUPPORTO	SUPPORT	TRÄGER	SUPPORT	SOPORTE
31	191037	2	DADO	ECROU	MUTTER	NUT	TUERCA
32	497167	2	VITE	VIS	SCHRAUBE	SCREW	TORNILLO
33	471290	3	TAPPO	BOUCHON	VERSCHLUSSDECKEL	PLUG	TAPON
34	403270	6	PROTEZIONE	PROTECTION	SCHUTZ	GUARD	PROTECCION
35	498164	8	VITE	VIS	SCHRAUBE	SCREW	TORNILLO
36	417003	22	RONDELLA	RONDELLE	SCHEIBE	WASHER	ARANDELA
37	467564	1	SUPPORTO	SUPPORT	TRÄGER	SUPPORT	SOPORTE
38	467561	1	SUPPORTO	SUPPORT	TRÄGER	SUPPORT	SOPORTE



COMPL. ATTIVAZIONE - RACCOGLITUBO (21024 - 23024 P)

* Compl. activation - serre-tubes
* Aktivierung - Ergänzung - Schlauchaufnahme
* Activation compl. - pipe holder
* Complet. activación - recogetubo

TAV. SV.03.02

matr. G107.0005

21
23 P

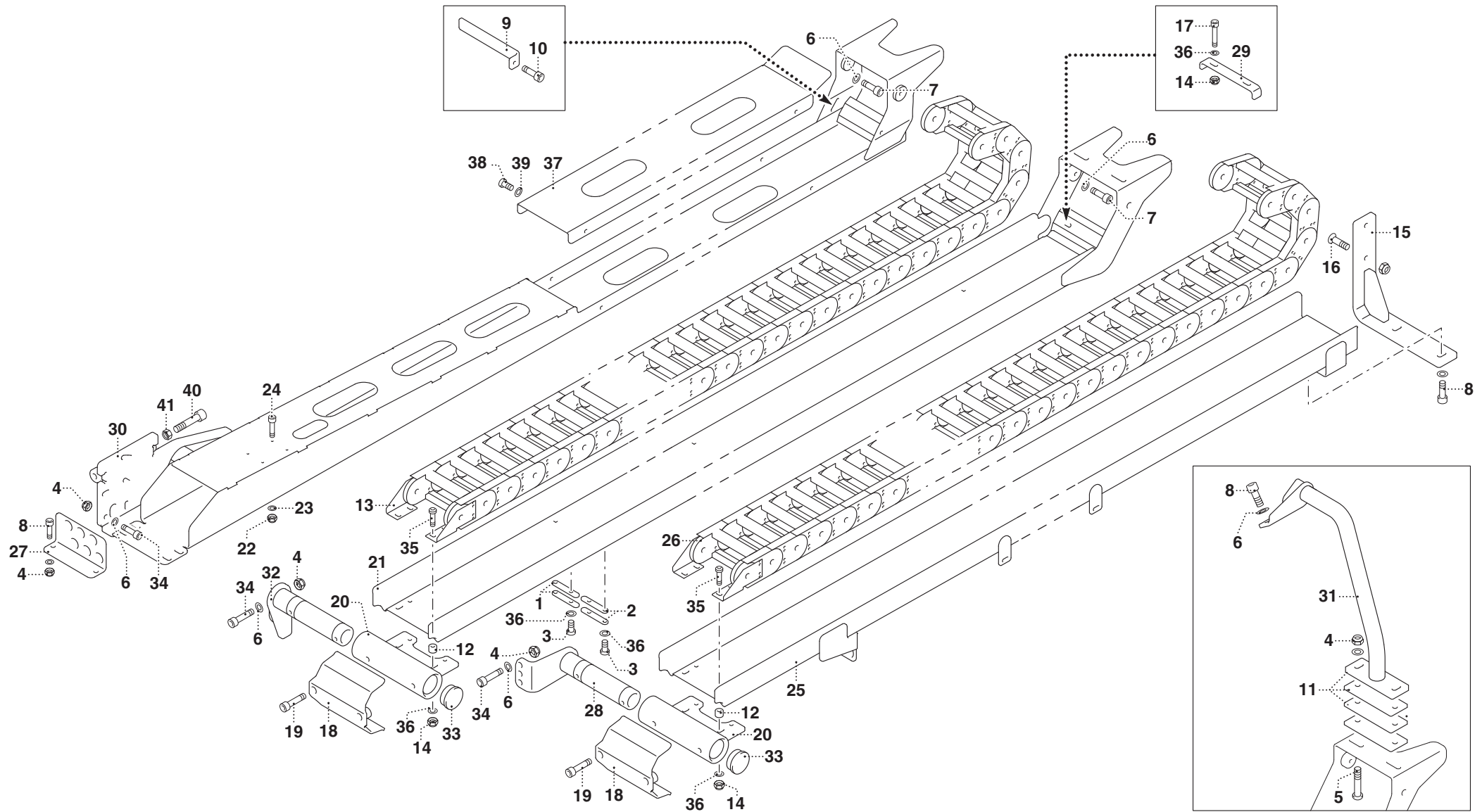

PM 21024 - PM 23024 P

matr. G107.0005

TAV. SV.03.02

POS.	N° CODICE	Q.	DESCRIZIONE	DESIGNATION	BENENNUNG	DESCRIPTION	DENOMINACIONES
1	467566	6	SUPPORTO	SUPPORT	TRÄGER	SUPPORT	SOPORTE
2	403270	6	PROTEZIONE	PROTECTION	SCHUTZ	GUARD	PROTECCION
3	497436	12	VITE	VIS	SCHRAUBE	SCREW	TORNILLO
4	191168	14	DADO	ECROU	MUTTER	NUT	TUERCA
5	497440	4	VITE	VIS	SCHRAUBE	SCREW	TORNILLO
6	417004	24	RONDELLA	RONDELLE	SCHEIBE	WASHER	ARANDELA
7	497383	4	VITE	VIS	SCHRAUBE	SCREW	TORNILLO
8	497131	7	VITE	VIS	SCHRAUBE	SCREW	TORNILLO
9	467565	1	SUPPORTO	SUPPORT	TRÄGER	SUPPORT	SOPORTE
10	497117	1	VITE	VIS	SCHRAUBE	SCREW	TORNILLO
11	314601	3	SUPPORTO	SUPPORT	TRÄGER	SUPPORT	SOPORTE
12	137392	8	BOCCOLA	DOUILLE	BUCHSE	BUSHING	CASQUILLO
13	151056	1	CATENA	CHAINE	KETTE	CHAIN	CADENA
14	191125	10	DADO	ECROU	MUTTER	NUT	TUERCA
15	467558	1	SUPPORTO	SUPPORT	TRÄGER	SUPPORT	SOPORTE
16	497208	2	VITE	VIS	SCHRAUBE	SCREW	TORNILLO
17	497123	2	VITE	VIS	SCHRAUBE	SCREW	TORNILLO
18	403254	2	PROTEZIONE	PROTECTION	SCHUTZ	GUARD	PROTECCION
19	497135	4	VITE	VIS	SCHRAUBE	SCREW	TORNILLO
20	120986	2	SUPPORTO	SUPPORT	TRÄGER	SUPPORT	SOPORTE
21	467553	1	SUPPORTO	SUPPORT	TRÄGER	SUPPORT	SOPORTE
22	191155	4	DADO	ECROU	MUTTER	NUT	TUERCA
23	417001	4	RONDELLA	RONDELLE	SCHEIBE	WASHER	ARANDELA
24	497835	4	VITE	VIS	SCHRAUBE	SCREW	TORNILLO
25	467554	1	SUPPORTO	SUPPORT	TRÄGER	SUPPORT	SOPORTE
26	151054	1	CATENA	CHAINE	KETTE	CHAIN	CADENA



COMPL. ATTIVAZIONE - RACCOGLITUBO (21024 - 23024 P)

* Compl. activation - serre-tubes
* Aktivierung - Ergänzung - Schlauchaufnahme
* Activation compl. - pipe holder
* Complet. activación - recogetubo

TAV. SV.03.02

matr. G107.0005

21
23 P

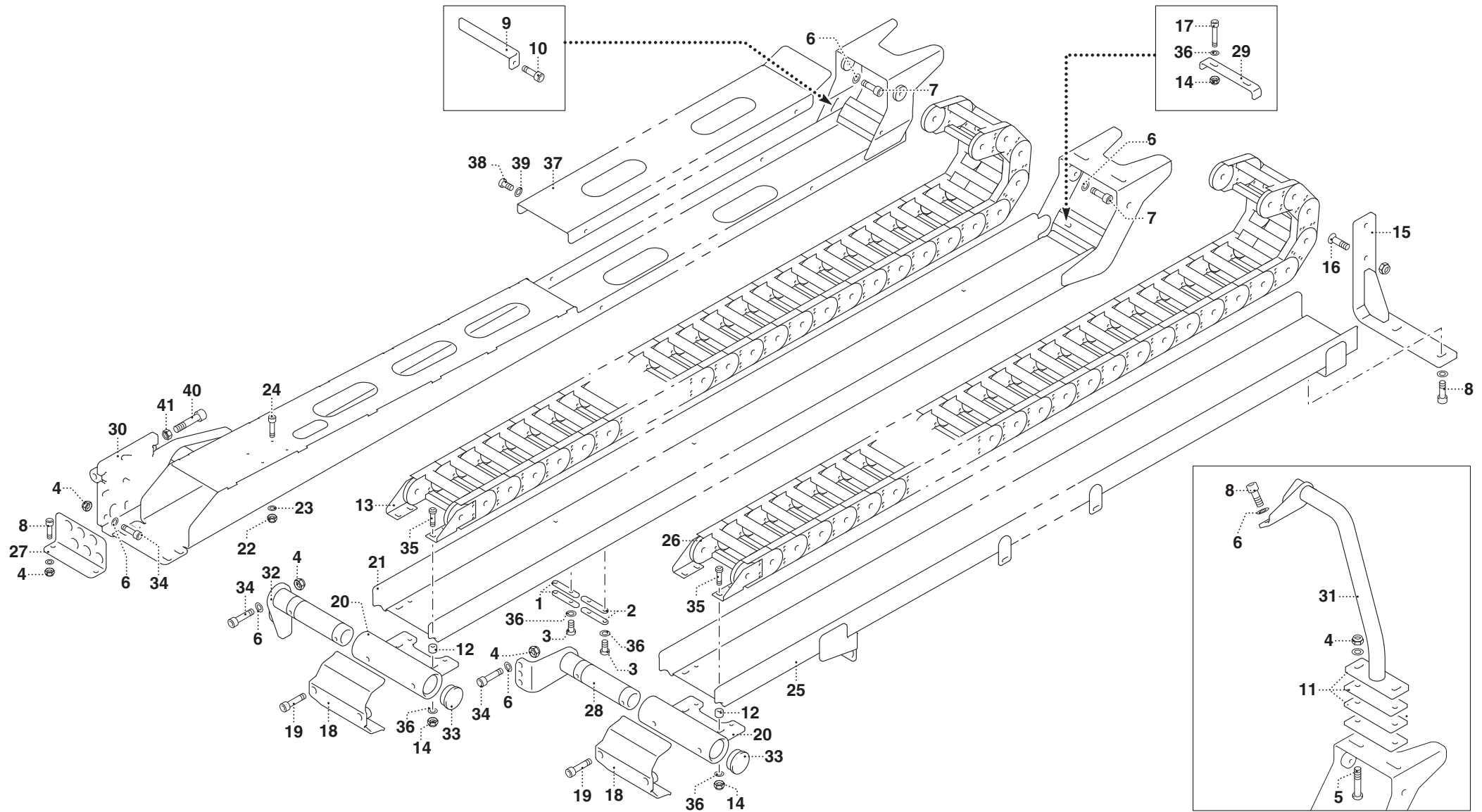

PM 21024 - PM 23024 P

matr. G107.0005

TAV. SV.03.02

POS.	N° CODICE	Q.	DESCRIZIONE	DESIGNATION	BENENNUNG	DESCRIPTION	DENOMINACIONES
27	467567	1	SUPPORTO	SUPPORT	TRÄGER	SUPPORT	SOPORTE
28	467555	1	SUPPORTO	SUPPORT	TRÄGER	SUPPORT	SOPORTE
29	467245	1	SUPPORTO	SUPPORT	TRÄGER	SUPPORT	SOPORTE
30	467562	1	SUPPORTO	SUPPORT	TRÄGER	SUPPORT	SOPORTE
31	467561	1	SUPPORTO	SUPPORT	TRÄGER	SUPPORT	SOPORTE
32	467556	1	SUPPORTO	SUPPORT	TRÄGER	SUPPORT	SOPORTE
33	471290	2	TAPPO	BOUCHON	VERSCHLUSSDECKEL	PLUG	TAPON
34	497134	11	VITE	VIS	SCHRAUBE	SCREW	TORNILLO
35	498164	8	VITE	VIS	SCHRAUBE	SCREW	TORNILLO
36	417003	22	RONDELLA	RONDELLE	SCHEIBE	WASHER	ARANDELA
37	176408	1	CARTER	CARTER	GEHAUSE	CASING	CARTER
38	497436	6	VITE	VIS	SCHRAUBE	SCREW	TORNILLO
39	417024	6	RONDELLA	RONDELLE	SCHEIBE	WASHER	ARANDELA
40	497167	2	VITE	VIS	SCHRAUBE	SCREW	TORNILLO
41	191037	2	DADO	ECROU	MUTTER	NUT	TUERCA



COMPL. ATTIVAZIONE - RACCOGLITUBO (21025 - 23025 P)

* Compl. activation - serre-tubes
* Aktivierung - Ergänzung - Schlauchaufnahme
* Activation compl. - pipe holder
* Complet. activación - recogetubo

TAV. SV.03.03 1/2

matr. G107.0005

21
23 P

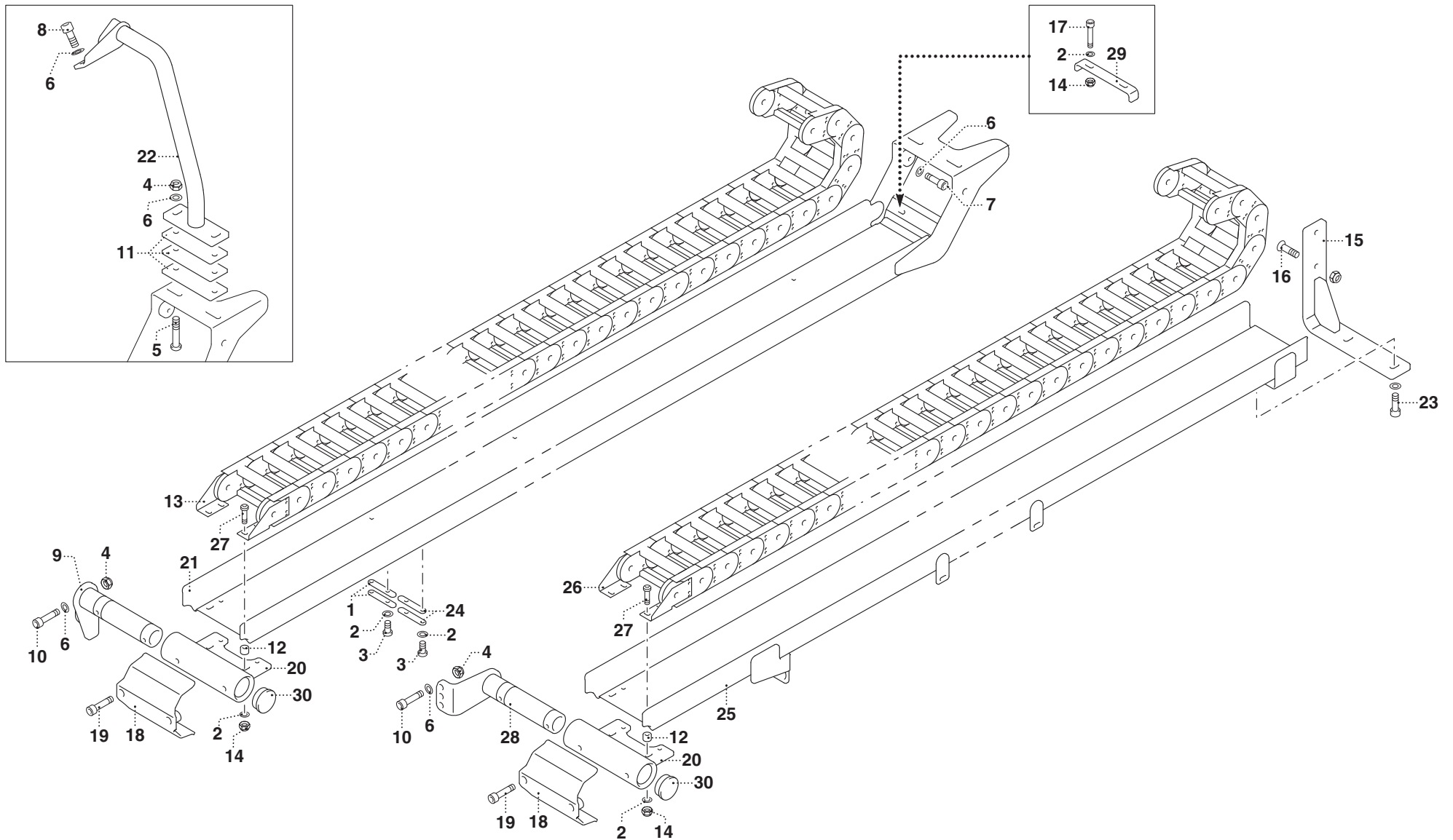

PM 21025 - PM 23025 P

matr. G107.0005

TAV. SV.03.03 1/2

POS.	N° CODICE	Q.	DESCRIZIONE	DESIGNATION	BENENNUNG	DESCRIPTION	DENOMINACIONES
1	467566	6	SUPPORTO	SUPPORT	TRÄGER	SUPPORT	SOPORTE
2	417003	6	RONDELLA	RONDELLE	SCHEIBE	WASHER	ARANDELA
3	497436	12	VITE	VIS	SCHRAUBE	SCREW	TORNILLO
4	191168	10	DADO	ECROU	MUTTER	NUT	TUERCA
5	497440	2	VITE	VIS	SCHRAUBE	SCREW	TORNILLO
6	417004	20	RONDELLA	RONDELLE	SCHEIBE	WASHER	ARANDELA
7	497383	2	VITE	VIS	SCHRAUBE	SCREW	TORNILLO
8	497131	5	VITE	VIS	SCHRAUBE	SCREW	TORNILLO
9	467556	1	SUPPORTO	SUPPORT	TRÄGER	SUPPORT	SOPORTE
10	497134	6	VITE	VIS	SCHRAUBE	SCREW	TORNILLO
11	314601	1	SUPPORTO	SUPPORT	TRÄGER	SUPPORT	SOPORTE
12	137392	8	BOCCOLA	DOUILLE	BUCHSE	BUSHING	CASQUILLO
13	151056	1	CATENA	CHAINE	KETTE	CHAIN	CADENA
14	191125	10	DADO	ECROU	MUTTER	NUT	TUERCA
15	467558	1	SUPPORTO	SUPPORT	TRÄGER	SUPPORT	SOPORTE
16	497208	2	VITE	VIS	SCHRAUBE	SCREW	TORNILLO
17	497123	2	VITE	VIS	SCHRAUBE	SCREW	TORNILLO
18	403254	2	PROTEZIONE	PROTECTION	SCHUTZ	GUARD	PROTECCION
19	497135	4	VITE	VIS	SCHRAUBE	SCREW	TORNILLO
20	120986	2	SUPPORTO	SUPPORT	TRÄGER	SUPPORT	SOPORTE
21	467553	1	SUPPORTO	SUPPORT	TRÄGER	SUPPORT	SOPORTE
22	467561	1	SUPPORTO	SUPPORT	TRÄGER	SUPPORT	SOPORTE
23	497132	2	VITE	VIS	SCHRAUBE	SCREW	TORNILLO
24	403270	3	PROTEZIONE	PROTECTION	SCHUTZ	GUARD	PROTECCION
25	467554	1	SUPPORTO	SUPPORT	TRÄGER	SUPPORT	SOPORTE
26	151054	1	CATENA	CHAINE	KETTE	CHAIN	CADENA



COMPL. ATTIVAZIONE - RACCOGLITUBO (21025 - 23025 P)

- * Compl. activation - serre-tubes
- * Aktivierung - Ergänzung - Schlauchaufnahme
- * Activation compl. - pipe holder
- * Complet. activación - recogetubo

TAV. SV.03.03 2/2

matr. G107.0005

21
23 P

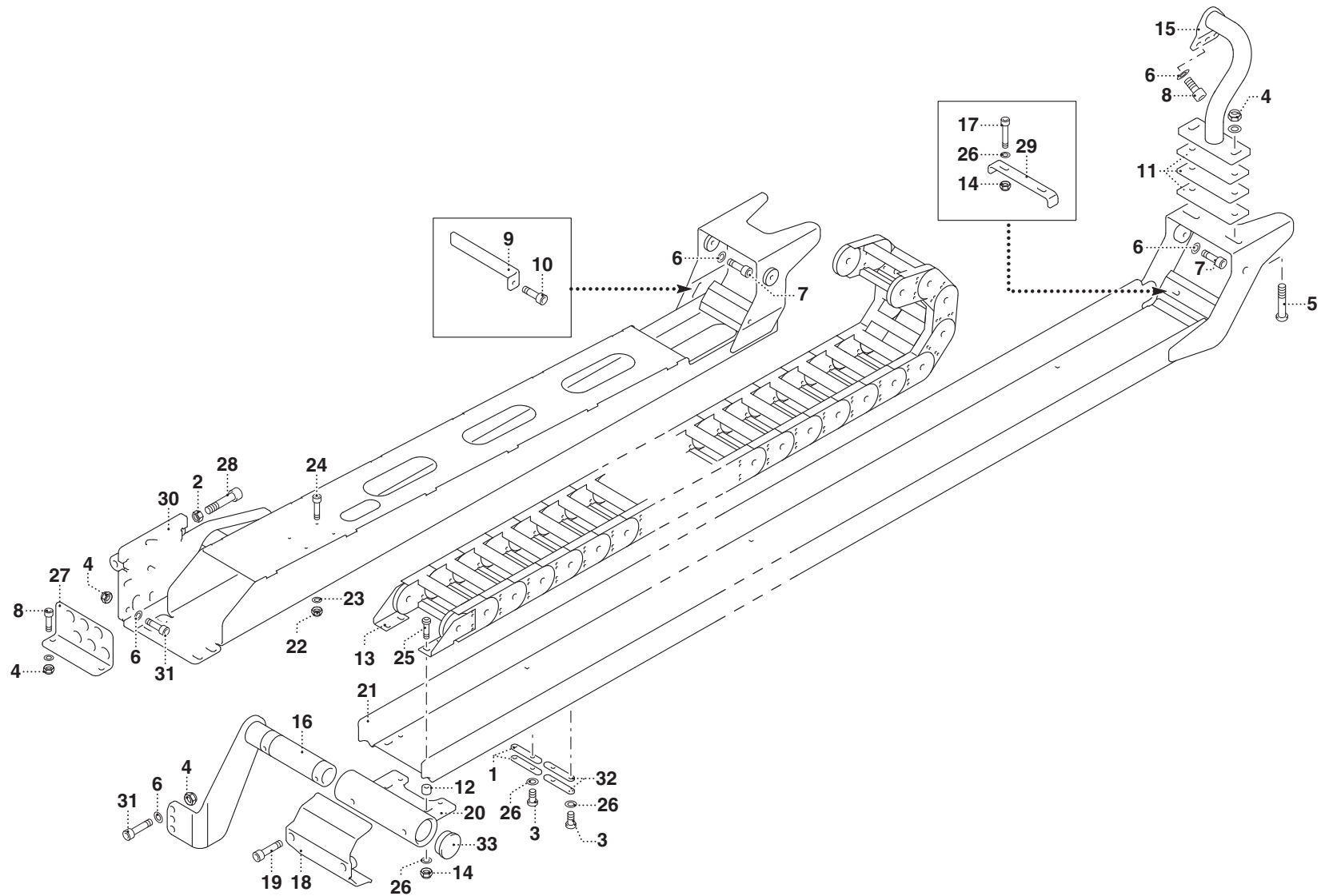

PM 21025 - PM 23025 P

matr. G107.0005

TAV. SV.03.03 2/2

POS.	N° CODICE	Q.	DESCRIZIONE	DESIGNATION	BENENNUNG	DESCRIPTION	DENOMINACIONES
1	467566	6	SUPPORTO	SUPPORT	TRÄGER	SUPPORT	SOPORTE
2	191037	2	DADO	ECROU	MUTTER	NUT	TUERCA
3	497436	12	VITE	VIS	SCHRAUBE	SCREW	TORNILLO
4	191168	13	DADO	ECROU	MUTTER	NUT	TUERCA
5	497440	2	VITE	VIS	SCHRAUBE	SCREW	TORNILLO
6	417004	16	RONDELLA	RONDELLE	SCHEIBE	WASHER	ARANDELA
7	497383	4	VITE	VIS	SCHRAUBE	SCREW	TORNILLO
8	497131	5	VITE	VIS	SCHRAUBE	SCREW	TORNILLO
9	467565	1	SUPPORTO	SUPPORT	TRÄGER	SUPPORT	SOPORTE
10	497117	1	VITE	VIS	SCHRAUBE	SCREW	TORNILLO
11	314601	1	SUPPORTO	SUPPORT	TRÄGER	SUPPORT	SOPORTE
12	137392	4	BOCCOLA	DOUILLE	BUCHSE	BUSHING	CASQUILLO
13	151055	1	CATENA	CHAINE	KETTE	CHAIN	CADENA
14	191125	6	DADO	ECROU	MUTTER	NUT	TUERCA
15	467560	1	SUPPORTO	SUPPORT	TRÄGER	SUPPORT	SOPORTE
16	467557	1	SUPPORTO	SUPPORT	TRÄGER	SUPPORT	SOPORTE
17	497123	2	VITE	VIS	SCHRAUBE	SCREW	TORNILLO
18	403254	1	PROTEZIONE	PROTECTION	SCHUTZ	GUARD	PROTECCION
19	497135	2	VITE	VIS	SCHRAUBE	SCREW	TORNILLO
20	120986	1	SUPPORTO	SUPPORT	TRÄGER	SUPPORT	SOPORTE
21	467552	1	SUPPORTO	SUPPORT	TRÄGER	SUPPORT	SOPORTE
22	191155	4	DADO	ECROU	MUTTER	NUT	TUERCA
23	417001	4	RONDELLA	RONDELLE	SCHEIBE	WASHER	ARANDELA
24	497835	4	VITE	VIS	SCHRAUBE	SCREW	TORNILLO
25	498164	4	VITE	VIS	SCHRAUBE	SCREW	TORNILLO
26	417003	18	RONDELLA	RONDELLE	SCHEIBE	WASHER	ARANDELA



COMPL. ATTIVAZIONE - RACCOGLITUBO (21025 - 23025 P)

* Compl. activation - serre-tubes
* Aktivierung - Ergänzung - Schlauchaufnahme
* Activation compl. - pipe holder
* Complet. activación - recogetubo

TAV. SV.03.03 2/2

matr. G107.0005

21
23 P

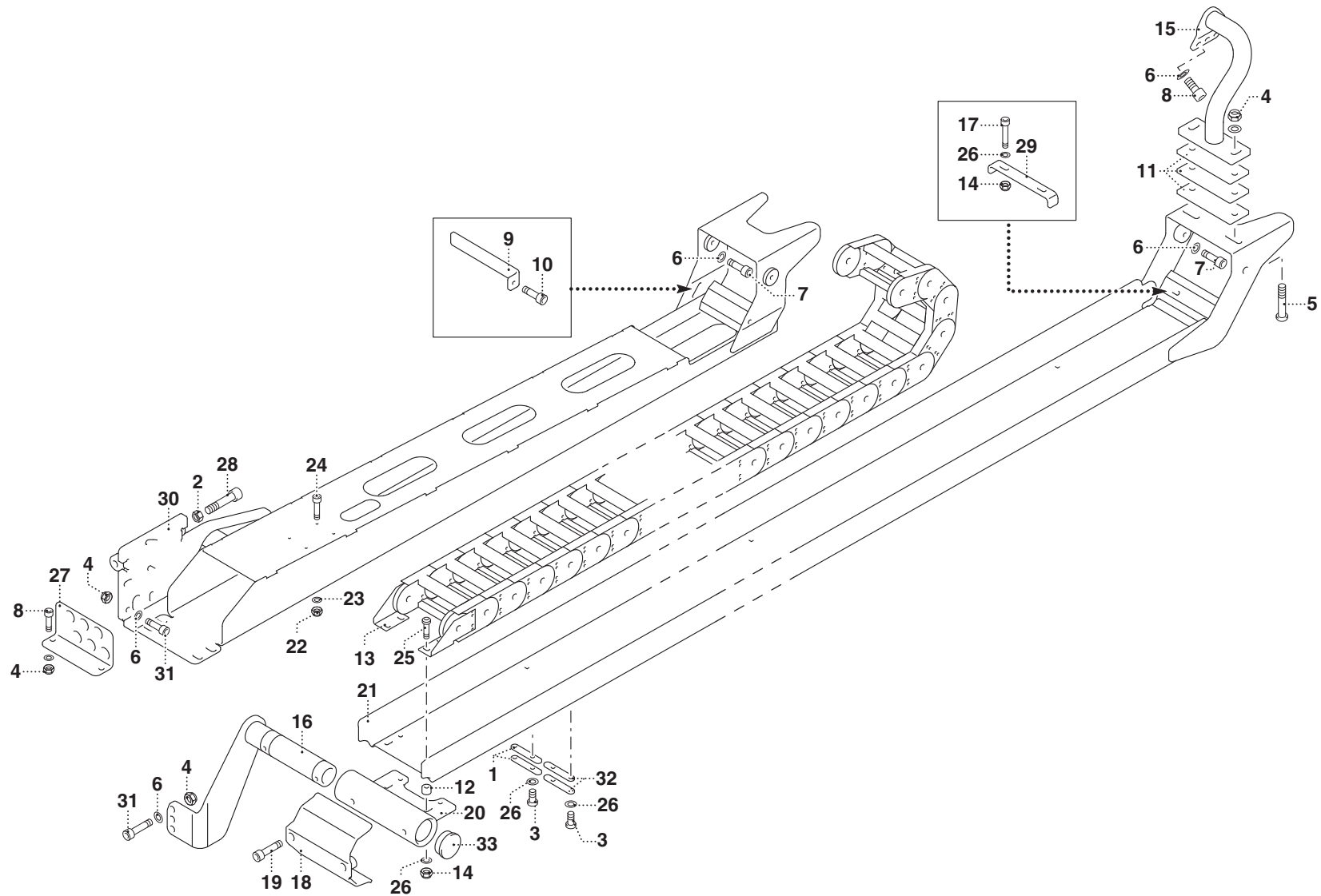

PM 21025 - PM 23025 P

matr. G107.0005

TAV. SV.03.03 2/2

POS.	N° CODICE	Q.	DESCRIZIONE	DESIGNATION	BENENNUNG	DESCRIPTION	DENOMINACIONES
27	467567	1	SUPPORTO	SUPPORT	TRÄGER	SUPPORT	SOPORTE
28	497167	2	VITE	VIS	SCHRAUBE	SCREW	TORNILLO
29	467245	1	SUPPORTO	SUPPORT	TRÄGER	SUPPORT	SOPORTE
30	467551	1	SUPPORTO	SUPPORT	TRÄGER	SUPPORT	SOPORTE
31	497134	7	VITE	VIS	SCHRAUBE	SCREW	TORNILLO
32	403270	3	PROTEZIONE	PROTECTION	SCHUTZ	GUARD	PROTECCION
33	471290	1	TAPPO	BOUCHON	VERSCHLUSSDECKEL	PLUG	TAPON



COMPL. COMANDO 1° ATTIVAZIONE - RACCOGLITUBO (21023 - 23023 P)

- * Compl. commande 1ère activation - serre-tubes
- * 1. Aktivierung Steuerung - Ergänzung - Schlauchaufnahme
- * 1st activation control compl. - pipe holder
- * Complet. mando 1° activación - recogetubo

TAV. SV.04.01

matr. G107.0005

21
23 P

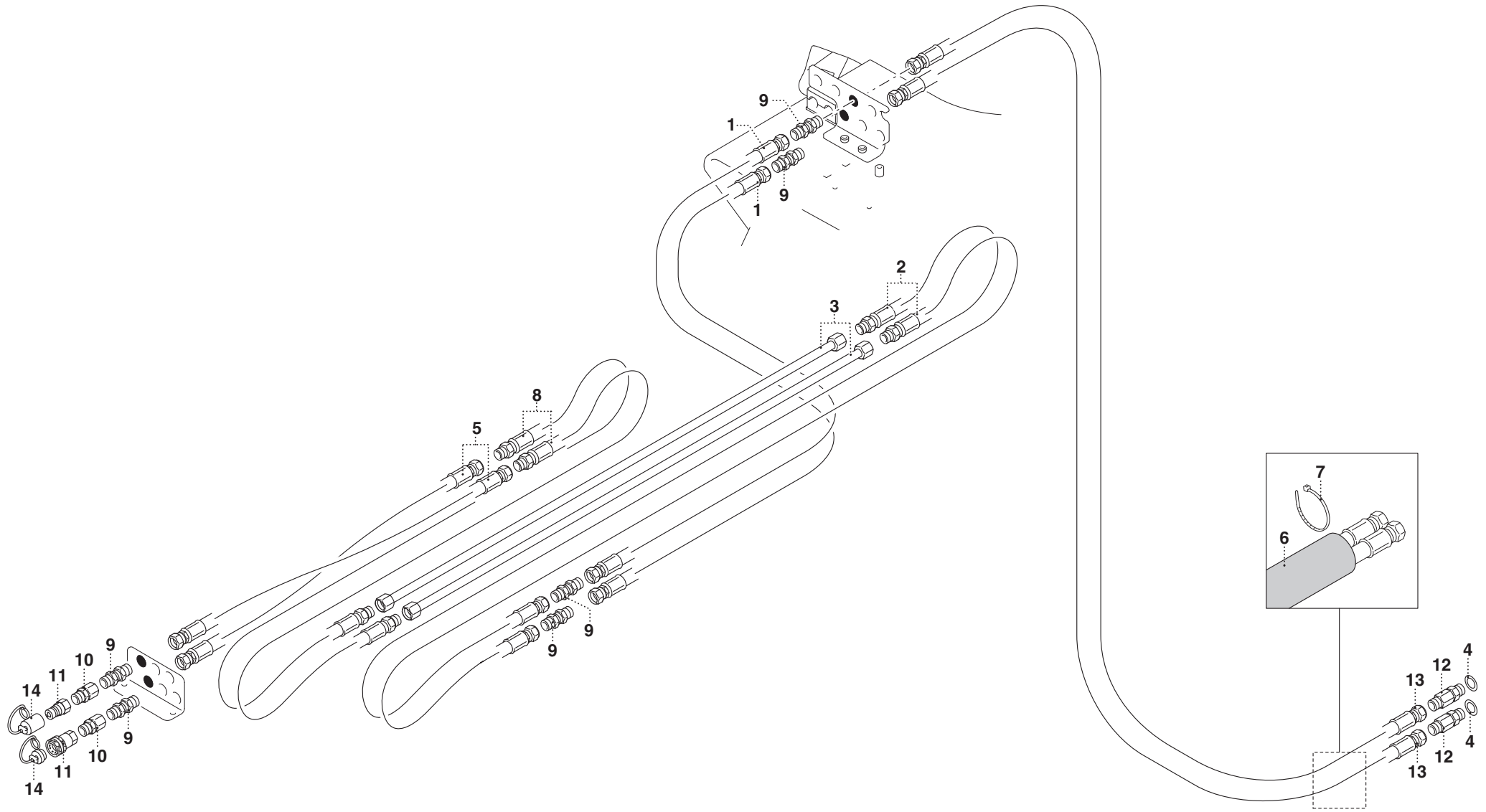

PM 21023 - PM 23023 P**matr. G107.0005****TAV. SV.04.01**

POS.	N° CODICE	Q.	DESCRIZIONE	DESIGNATION	BENENNUNG	DESCRIPTION	DENOMINACIONES
1	485847	2	TUBO FLESSIBILE	TUYAU FLEXIBLE	SCHLAUCH	FLEXIBLE HOSE	TUBO FLEXIBLE
2	482528	2	TUBO FLESSIBILE	TUYAU FLEXIBLE	SCHLAUCH	FLEXIBLE HOSE	TUBO FLEXIBLE
3	460180	2	TUBO RIGIDO	TUYAU RIGIDE	ROHR	PIPE	TUBO RIGIDO
4	417092	2	RONDELLA	RONDELLE	SCHEIBE	WASHER	ARANDELA
5	485281	2	TUBO FLESSIBILE	TUYAU FLEXIBLE	SCHLAUCH	FLEXIBLE HOSE	TUBO FLEXIBLE
6	276081	1	GUAINA	GAINÉ	MANTEL	SHEATH	VAINA
7	207064	2	FASCETTA	COLLIER	HALTEBAND	CLAMP	ABRAZADERA
8	482530	2	TUBO FLESSIBILE	TUYAU FLEXIBLE	SCHLAUCH	FLEXIBLE HOSE	TUBO FLEXIBLE
9	410164	6	RACCORDO	RACCORD	ANSCHLUSS	FITTING	RACOR
10	409630	2	RACCORDO	RACCORD	ANSCHLUSS	FITTING	RACOR
11	124006	2	INNESTO RAPIDO	CONNECTION RAPIDE	SCHNELLKUPPLUNG	FAST COUPLING	CONEXION RAPIDA
12	239268	2	RACCORDO	RACCORD	ANSCHLUSS	FITTING	RACOR
13	482535	2	TUBO FLESSIBILE	TUYAU FLEXIBLE	SCHLAUCH	FLEXIBLE HOSE	TUBO FLEXIBLE
14	288909	1	KIT TAPPO	KIT BOUCHON	VERSCHLUSSDECKELSATZ	PLUG KIT	KIT TAPON



COMPL. COMANDO 1° ATTIVAZIONE - RACCOGLITUBO (21024 - 23024 P)

- * Compl. commande 1ère activation - serre-tubes
- * 1. Aktivierung Steuerung - Ergänzung - Schlauchaufnahme
- * 1st activation control compl. - pipe holder
- * Complet. mando 1° activación - recogetubo

TAV. SV.04.02

matr. G107.0005

21
23 P

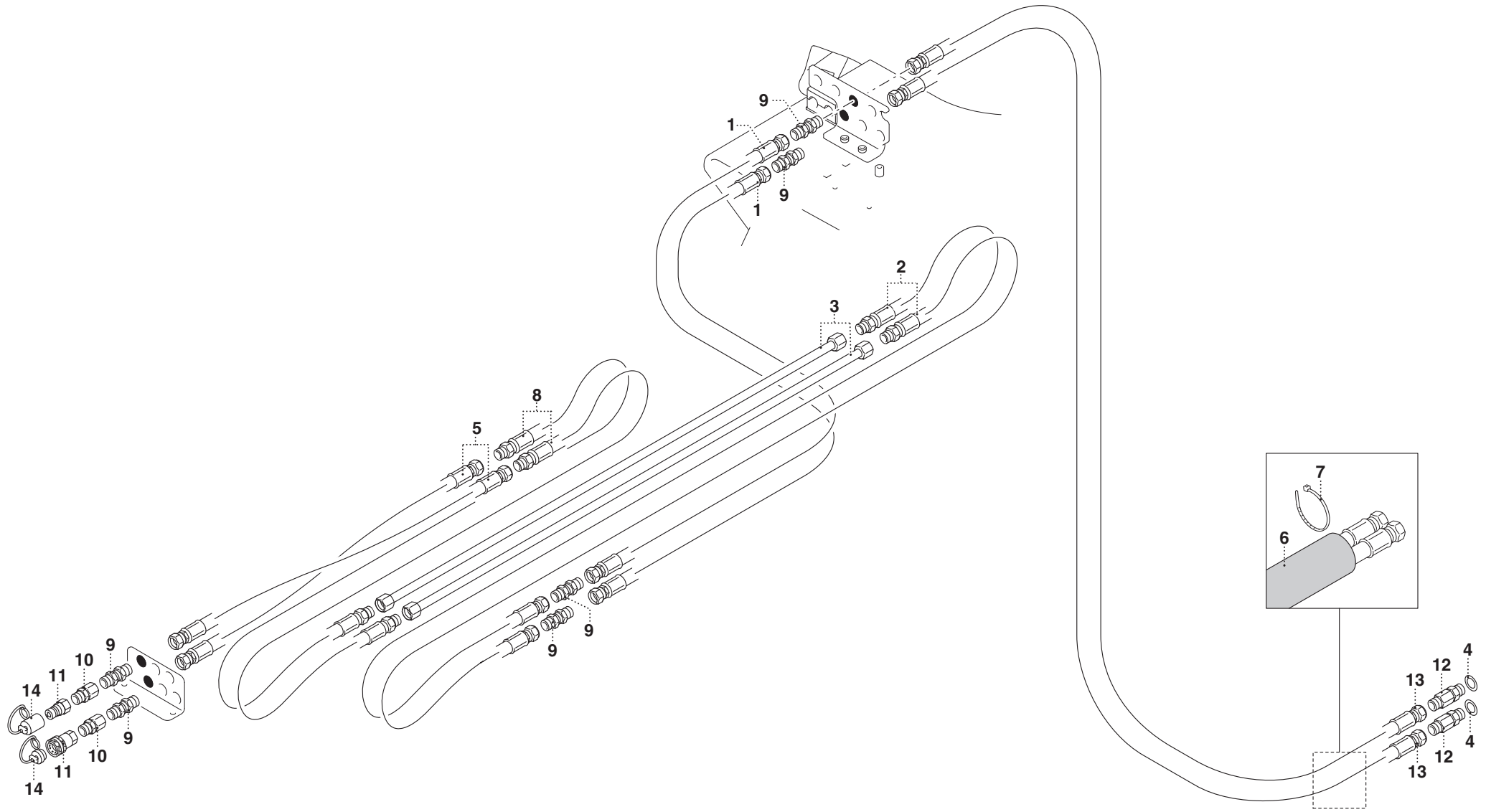

PM 21024 - PM 23024 P**matr. G107.0005****TAV. SV.04.02**

POS.	N° CODICE	Q.	DESCRIZIONE	DESIGNATION	BENENNUNG	DESCRIPTION	DENOMINACIONES
1	485847	2	TUBO FLESSIBILE	TUYAU FLEXIBLE	SCHLAUCH	FLEXIBLE HOSE	TUBO FLEXIBLE
2	482528	2	TUBO FLESSIBILE	TUYAU FLEXIBLE	SCHLAUCH	FLEXIBLE HOSE	TUBO FLEXIBLE
3	460181	2	TUBO RIGIDO	TUYAU RIGIDE	ROHR	PIPE	TUBO RIGIDO
4	417092	2	RONDELLA	RONDELLE	SCHEIBE	WASHER	ARANDELA
5	486138	2	TUBO FLESSIBILE	TUYAU FLEXIBLE	SCHLAUCH	FLEXIBLE HOSE	TUBO FLEXIBLE
6	276081	1	GUAINA	GAINÉ	MANTEL	SHEATH	VAINA
7	207064	2	FASCETTA	COLLIER	HALTEBAND	CLAMP	ABRAZADERA
8	482532	2	TUBO FLESSIBILE	TUYAU FLEXIBLE	SCHLAUCH	FLEXIBLE HOSE	TUBO FLEXIBLE
9	410164	6	RACCORDO	RACCORD	ANSCHLUSS	FITTING	RACOR
10	409630	2	RACCORDO	RACCORD	ANSCHLUSS	FITTING	RACOR
11	124006	2	INNESTO RAPIDO	CONNECTION RAPIDE	SCHNELLKUPPLUNG	FAST COUPLING	CONEXION RAPIDA
12	239268	2	RACCORDO	RACCORD	ANSCHLUSS	FITTING	RACOR
13	482535	2	TUBO FLESSIBILE	TUYAU FLEXIBLE	SCHLAUCH	FLEXIBLE HOSE	TUBO FLEXIBLE
14	288909	1	KIT TAPPO	KIT BOUCHON	VERSCHLUSSDECKELSATZ	PLUG KIT	KIT TAPON



COMPL. COMANDO 1° ATTIVAZIONE - RACCOGLITUBO (21025 - 23025 P)

- * Compl. commande 1ère activation - serre-tubes
- * 1. Aktivierung Steuerung - Ergänzung - Schlauchaufnahme
- * 1st activation control compl. - pipe holder
- * Complet. mando 1° activación - recogetubo

TAV. SV.04.03

matr. G107.0005

21
23 P

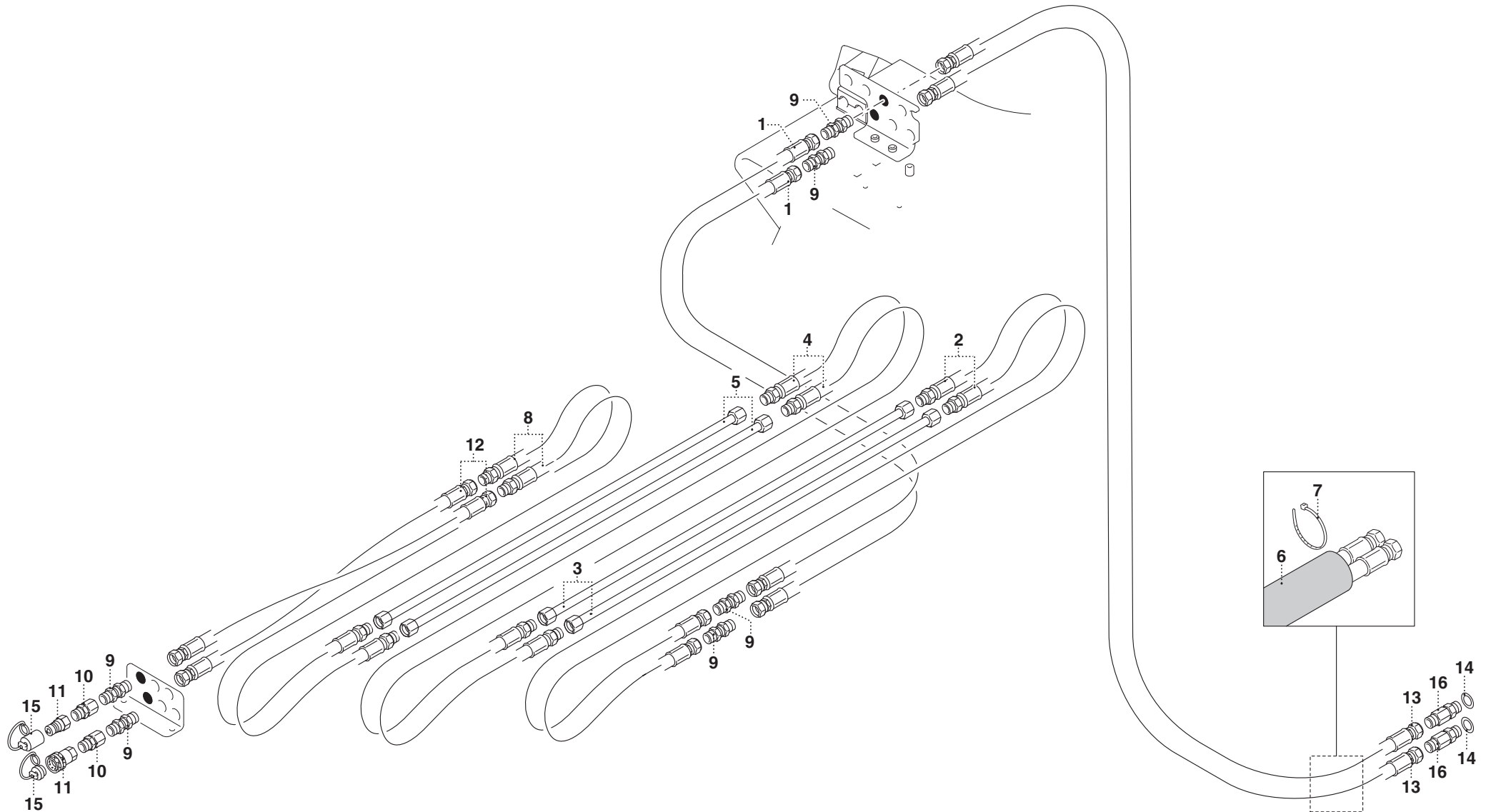

PM 21025 - PM 23025 P**matr. G107.0005****TAV. SV.04.03**

POS.	N° CODICE	Q.	DESCRIZIONE	DESIGNATION	BENENNUNG	DESCRIPTION	DENOMINACIONES
1	485847	2	TUBO FLESSIBILE	TUYAU FLEXIBLE	SCHLAUCH	FLEXIBLE HOSE	TUBO FLEXIBLE
2	482528	2	TUBO FLESSIBILE	TUYAU FLEXIBLE	SCHLAUCH	FLEXIBLE HOSE	TUBO FLEXIBLE
3	460180	2	TUBO RIGIDO	TUYAU RIGIDE	ROHR	PIPE	TUBO RIGIDO
4	482532	2	TUBO FLESSIBILE	TUYAU FLEXIBLE	SCHLAUCH	FLEXIBLE HOSE	TUBO FLEXIBLE
5	460181	2	TUBO RIGIDO	TUYAU RIGIDE	ROHR	PIPE	TUBO RIGIDO
6	276081	1	GUAINA	GAINÉ	MANTEL	SHEATH	VAINA
7	207064	2	FASCETTA	COLLIER	HALTEBAND	CLAMP	ABRAZADERA
8	482530	2	TUBO FLESSIBILE	TUYAU FLEXIBLE	SCHLAUCH	FLEXIBLE HOSE	TUBO FLEXIBLE
9	410164	6	RACCORDO	RACCORD	ANSCHLUSS	FITTING	RACOR
10	409630	2	RACCORDO	RACCORD	ANSCHLUSS	FITTING	RACOR
11	124006	2	INNESTO RAPIDO	CONNECTION RAPIDE	SCHNELLKUPPLUNG	FAST COUPLING	CONEXION RAPIDA
12	485281	2	TUBO FLESSIBILE	TUYAU FLEXIBLE	SCHLAUCH	FLEXIBLE HOSE	TUBO FLEXIBLE
13	482535	2	TUBO FLESSIBILE	TUYAU FLEXIBLE	SCHLAUCH	FLEXIBLE HOSE	TUBO FLEXIBLE
14	417092	2	RONDELLA	RONDELLE	SCHEIBE	WASHER	ARANDELA
15	288909	1	KIT TAPPO	KIT BOUCHON	VERSCHLUSSDECKELSATZ	PLUG KIT	KIT TAPON
16	239268	2	RACCORDO	RACCORD	ANSCHLUSS	FITTING	RACOR



COMPL. COMANDO 1° ATTIVAZIONE - RACCOGLITUBO - 3° PUNTO DI MANOVRA (21023 - 23023 P)

- * Compl. commande 1ère activation - serre-tubes - 3ème point de manœuvre
- * 1. Aktivierung Steuerung - Ergänzung - Schlauchaufnahme - 3. Manöverplatz
- * 1st activation control compl. - pipe holder - 3rd manoeuvre position
- * Complet. mando 1° activación - recogetubo - 3er punto de maniobra

TAV. SV.04.04

matr. G107.0005

21
23 P

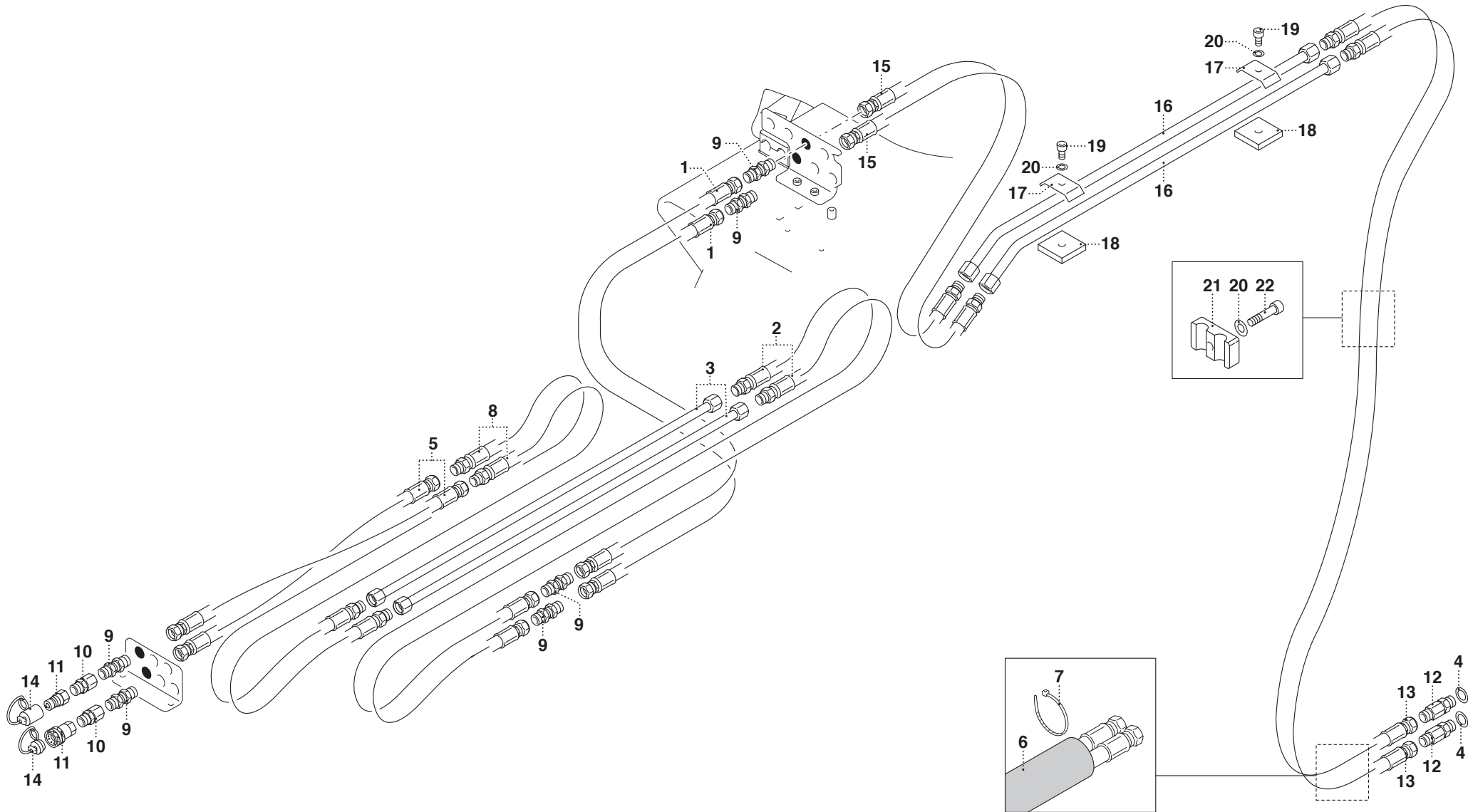

PM 21023 - PM 23023 P**matr. G107.0005****TAV. SV.04.04**

POS.	N° CODICE	Q.	DESCRIZIONE	DESIGNATION	BENENNUNG	DESCRIPTION	DENOMINACIONES
1	485847	2	TUBO FLESSIBILE	TUYAU FLEXIBLE	SCHLAUCH	FLEXIBLE HOSE	TUBO FLEXIBLE
2	482528	2	TUBO FLESSIBILE	TUYAU FLEXIBLE	SCHLAUCH	FLEXIBLE HOSE	TUBO FLEXIBLE
3	460180	2	TUBO RIGIDO	TUYAU RIGIDE	ROHR	PIPE	TUBO RIGIDO
4	417092	2	RONDELLA	RONDELLE	SCHEIBE	WASHER	ARANDELA
5	485281	2	TUBO FLESSIBILE	TUYAU FLEXIBLE	SCHLAUCH	FLEXIBLE HOSE	TUBO FLEXIBLE
6	276081	1	GUAINA	GAINE	MANTEL	SHEATH	VAINA
7	207064	2	FASCETTA	COLLIER	HALTEBAND	CLAMP	ABRAZADERA
8	482530	2	TUBO FLESSIBILE	TUYAU FLEXIBLE	SCHLAUCH	FLEXIBLE HOSE	TUBO FLEXIBLE
9	410164	6	RACCORDO	RACCORD	ANSCHLUSS	FITTING	RACOR
10	409630	2	RACCORDO	RACCORD	ANSCHLUSS	FITTING	RACOR
11	124006	2	INNESTO RAPIDO	CONNECTION RAPIDE	SCHNELLKUPPLUNG	FAST COUPLING	CONEXION RAPIDA
12	239268	2	RACCORDO	RACCORD	ANSCHLUSS	FITTING	RACOR
13	482603	2	TUBO FLESSIBILE	TUYAU FLEXIBLE	SCHLAUCH	FLEXIBLE HOSE	TUBO FLEXIBLE
14	288909	1	KIT TAPPO	KIT BOUCHON	VERSCHLUSSDECKELSATZ	PLUG KIT	KIT TAPON
15	482605	2	TUBO FLESSIBILE	TUYAU FLEXIBLE	SCHLAUCH	FLEXIBLE HOSE	TUBO FLEXIBLE
16	460339	2	TUBO RIGIDO	TUYAU RIGIDE	ROHR	PIPE	TUBO RIGIDO
17	353099	2	MORSETTO	ETAU	KLEMME	CLAMP	PRENSOR
18	292170	2	SPESSORE	EPAISSEUR	DICKE	THICKNESS	ESPEJOR
19	497132	2	VITE	VIS	SCHRAUBE	SCREW	TORNILLO
20	417025	3	RONDELLA	RONDELLE	SCHEIBE	WASHER	ARANDELA
21	353073	1	MORSETTO	ETAU	KLEMME	CLAMP	PRENSOR
22	497134	1	VITE	VIS	SCHRAUBE	SCREW	TORNILLO



COMPL. COMANDO 1° ATTIVAZIONE - RACCOGLITUBO - 3° PUNTO DI MANOVRA (21024 - 23024 P)

- * Compl. commande 1ère activation - serre-tubes - 3ème point de manœuvre
- * 1. Aktivierung Steuerung - Ergänzung - Schlauchaufnahme - 3. Manöverplatz
- * 1st activation control compl. - pipe holder - 3rd manoeuvre position
- * Complet. mando 1° activación - recogetubo - 3er punto de maniobra

TAV. SV.04.05

matr. G107.0005

21
23 P

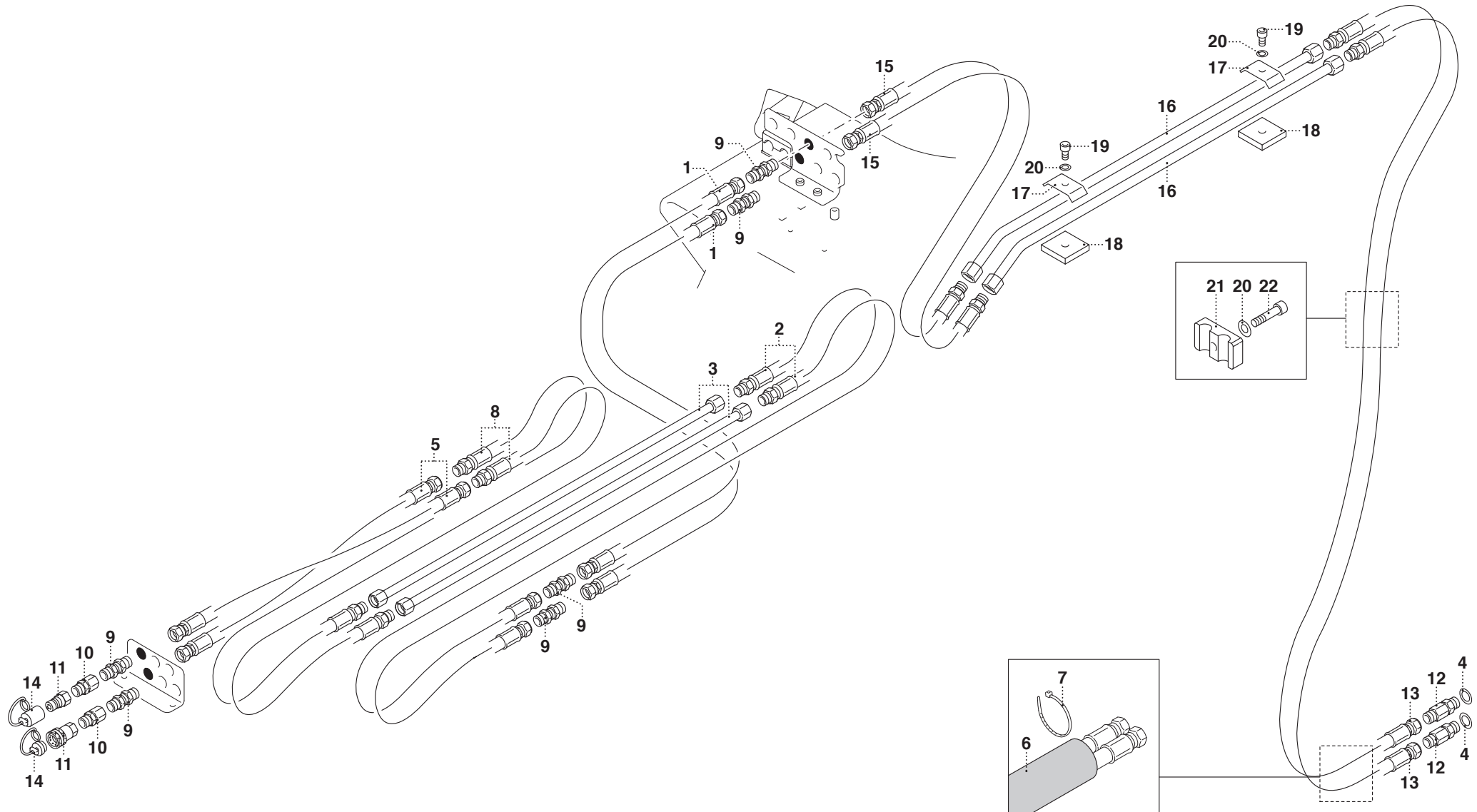

PM 21024 - PM 23024 P**matr. G107.0005****TAV. SV.04.05**

POS.	N° CODICE	Q.	DESCRIZIONE	DESIGNATION	BENENNUNG	DESCRIPTION	DENOMINACIONES
1	485847	2	TUBO FLESSIBILE	TUYAU FLEXIBLE	SCHLAUCH	FLEXIBLE HOSE	TUBO FLEXIBLE
2	482528	2	TUBO FLESSIBILE	TUYAU FLEXIBLE	SCHLAUCH	FLEXIBLE HOSE	TUBO FLEXIBLE
3	460180	2	TUBO RIGIDO	TUYAU RIGIDE	ROHR	PIPE	TUBO RIGIDO
4	417092	2	RONDELLA	RONDELLE	SCHEIBE	WASHER	ARANDELA
5	485281	2	TUBO FLESSIBILE	TUYAU FLEXIBLE	SCHLAUCH	FLEXIBLE HOSE	TUBO FLEXIBLE
6	276081	1	GUAINA	GAINÉ	MANTEL	SHEATH	VAINA
7	207064	2	FASCETTA	COLLIER	HALTEBAND	CLAMP	ABRAZADERA
8	482530	2	TUBO FLESSIBILE	TUYAU FLEXIBLE	SCHLAUCH	FLEXIBLE HOSE	TUBO FLEXIBLE
9	410164	6	RACCORDO	RACCORD	ANSCHLUSS	FITTING	RACOR
10	409630	2	RACCORDO	RACCORD	ANSCHLUSS	FITTING	RACOR
11	124006	2	INNESTO RAPIDO	CONNECTION RAPIDE	SCHNELLKUPPLUNG	FAST COUPLING	CONEXION RAPIDA
12	239268	2	RACCORDO	RACCORD	ANSCHLUSS	FITTING	RACOR
13	482603	2	TUBO FLESSIBILE	TUYAU FLEXIBLE	SCHLAUCH	FLEXIBLE HOSE	TUBO FLEXIBLE
14	288909	1	KIT TAPPO	KIT BOUCHON	VERSCHLUSSDECKELSATZ	PLUG KIT	KIT TAPON
15	482605	2	TUBO FLESSIBILE	TUYAU FLEXIBLE	SCHLAUCH	FLEXIBLE HOSE	TUBO FLEXIBLE
16	460339	2	TUBO RIGIDO	TUYAU RIGIDE	ROHR	PIPE	TUBO RIGIDO
17	353099	2	MORSETTO	ETAU	KLEMME	CLAMP	PRENSOR
18	292170	2	SPESSORE	EPAISSEUR	DICKE	THICKNESS	ESPEJOR
19	497132	2	VITE	VIS	SCHRAUBE	SCREW	TORNILLO
20	417025	3	RONDELLA	RONDELLE	SCHEIBE	WASHER	ARANDELA
21	353073	1	MORSETTO	ETAU	KLEMME	CLAMP	PRENSOR
22	497134	1	VITE	VIS	SCHRAUBE	SCREW	TORNILLO



COMPL. COMANDO 1° ATTIVAZIONE - RACCOGLITUBO - 3° PUNTO DI MANOVRA (21025 - 23025 P)

- * Compl. commande 1ère activation - serre-tubes - 3ème point de manœuvre
- * 1. Aktivierung Steuerung - Ergänzung - Schlauchaufnahme - 3. Manöverplatz
- * 1st activation control compl. - pipe holder - 3rd manoeuvre position
- * Complet. mando 1° activación - recogetubo - 3er punto de maniobra

TAV. SV.04.06

matr. G107.0005

21
23 P

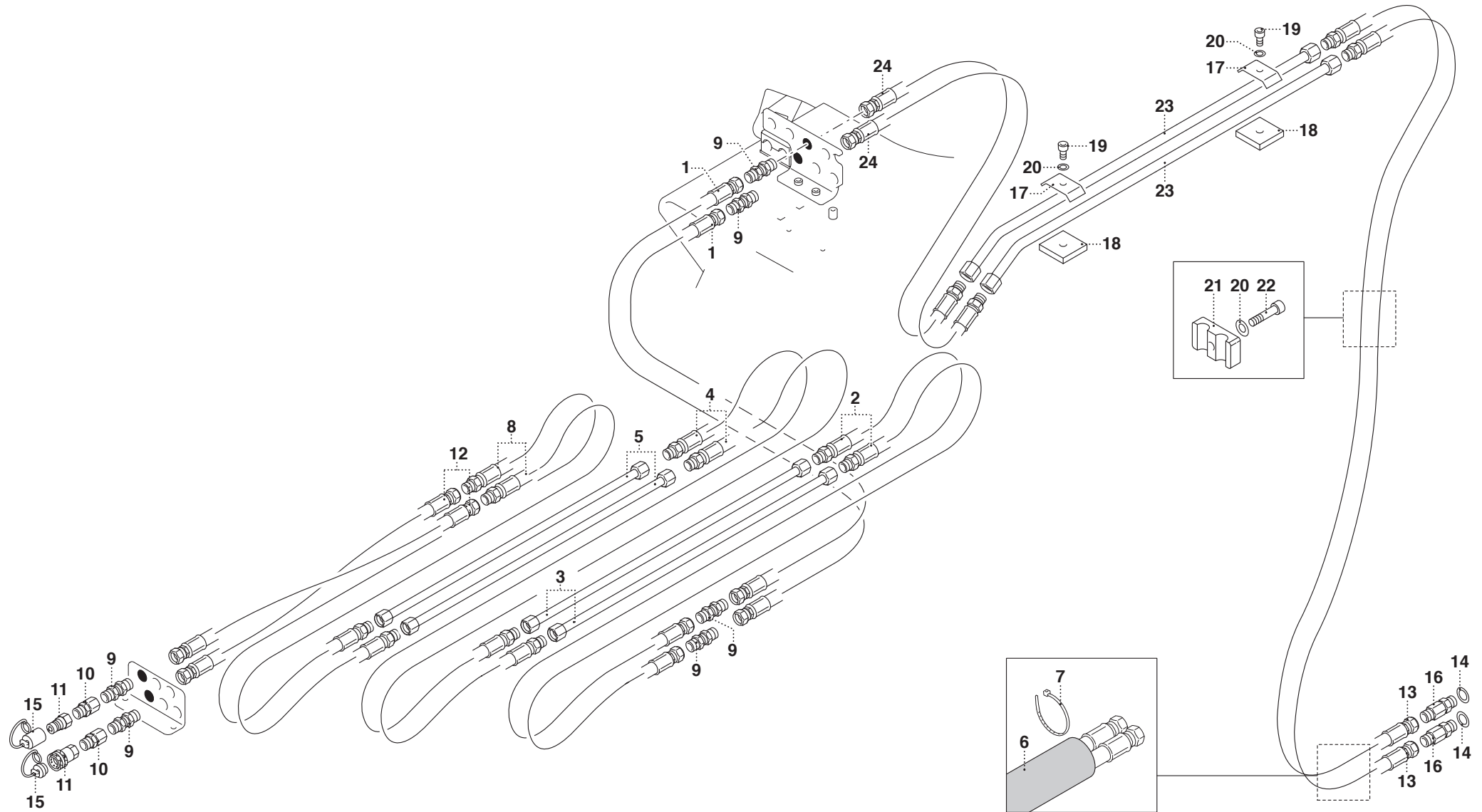

PM 21025 - PM 23025 P**matr. G107.0005****TAV. SV.04.06**

POS.	N° CODICE	Q.	DESCRIZIONE	DESIGNATION	BENENNUNG	DESCRIPTION	DENOMINACIONES
1	485847	2	TUBO FLESSIBILE	TUYAU FLEXIBLE	SCHLAUCH	FLEXIBLE HOSE	TUBO FLEXIBLE
2	482528	2	TUBO FLESSIBILE	TUYAU FLEXIBLE	SCHLAUCH	FLEXIBLE HOSE	TUBO FLEXIBLE
3	460180	2	TUBO RIGIDO	TUYAU RIGIDE	ROHR	PIPE	TUBO RIGIDO
4	482532	2	TUBO FLESSIBILE	TUYAU FLEXIBLE	SCHLAUCH	FLEXIBLE HOSE	TUBO FLEXIBLE
5	460181	2	TUBO RIGIDO	TUYAU RIGIDE	ROHR	PIPE	TUBO RIGIDO
6	276081	1	GUAINA	GAINÉ	MANTEL	SHEATH	VAINA
7	207064	2	FASCETTA	COLLIER	HALTEBAND	CLAMP	ABRAZADERA
8	482530	2	TUBO FLESSIBILE	TUYAU FLEXIBLE	SCHLAUCH	FLEXIBLE HOSE	TUBO FLEXIBLE
9	410164	6	RACCORDO	RACCORD	ANSCHLUSS	FITTING	RACOR
10	409630	2	RACCORDO	RACCORD	ANSCHLUSS	FITTING	RACOR
11	124006	2	INNESTO RAPIDO	CONNECTION RAPIDE	SCHNELLKUPPLUNG	FAST COUPLING	CONEXION RAPIDA
12	485281	2	TUBO FLESSIBILE	TUYAU FLEXIBLE	SCHLAUCH	FLEXIBLE HOSE	TUBO FLEXIBLE
13	482603	2	TUBO FLESSIBILE	TUYAU FLEXIBLE	SCHLAUCH	FLEXIBLE HOSE	TUBO FLEXIBLE
14	417092	2	RONDELLA	RONDELLE	SCHEIBE	WASHER	ARANDELA
15	288909	1	KIT TAPPO	KIT BOUCHON	VERSCHLUSSDECKELSATZ	PLUG KIT	KIT TAPON
16	239268	2	RACCORDO	RACCORD	ANSCHLUSS	FITTING	RACOR
17	353099	2	MORSETTO	ETAU	KLEMME	CLAMP	PRENSOR
18	292170	2	SPESSORE	EPAISSEUR	DICKE	THICKNESS	ESPEJOR
19	497132	2	VITE	VIS	SCHRAUBE	SCREW	TORNILLO
20	417025	3	RONDELLA	RONDELLE	SCHEIBE	WASHER	ARANDELA
21	353073	1	MORSETTO	ETAU	KLEMME	CLAMP	PRENSOR
22	497134	1	VITE	VIS	SCHRAUBE	SCREW	TORNILLO
23	460339	2	TUBO RIGIDO	TUYAU RIGIDE	ROHR	PIPE	TUBO RIGIDO
24	482605	2	TUBO FLESSIBILE	TUYAU FLEXIBLE	SCHLAUCH	FLEXIBLE HOSE	TUBO FLEXIBLE



COMPL. COMANDO 2° ATTIVAZIONE - RACCOGLITUBO (21023 - 23023 P)

- * Compl. commande 2ème activation - serre-tubes
- * 2. Aktivierung Steuerung - Ergänzung - Schlauchaufnahme
- * 2nd activation control compl. - pipe holder
- * Complet. mando 2º activación - recogetubo

TAV. SV.05.01

matr. G107.0005

21
23 P

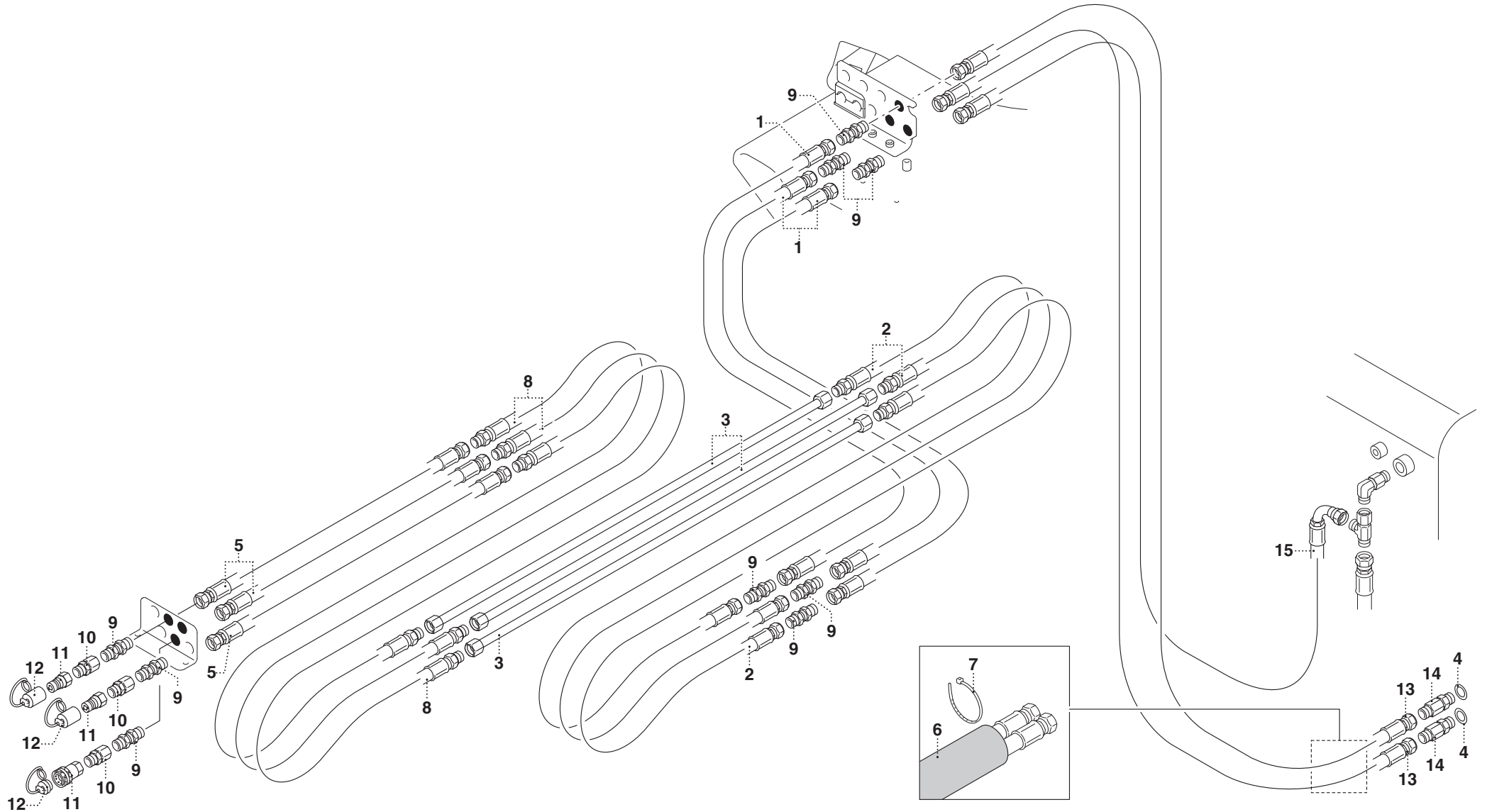

UN01-R-1694-MG

PM 21023 - PM 23023 P**matr. G107.0005****TAV. SV.05.01**

POS.	N° CODICE	Q.	DESCRIZIONE	DESIGNATION	BENENNUNG	DESCRIPTION	DENOMINACIONES
1	485847	3	TUBO FLESSIBILE	TUYAU FLEXIBLE	SCHLAUCH	FLEXIBLE HOSE	TUBO FLEXIBLE
2	482529	3	TUBO FLESSIBILE	TUYAU FLEXIBLE	SCHLAUCH	FLEXIBLE HOSE	TUBO FLEXIBLE
3	460180	3	TUBO RIGIDO	TUYAU RIGIDE	ROHR	PIPE	TUBO RIGIDO
4	417092	2	RONDELLA	RONDELLE	SCHEIBE	WASHER	ARANDELA
5	485281	3	TUBO FLESSIBILE	TUYAU FLEXIBLE	SCHLAUCH	FLEXIBLE HOSE	TUBO FLEXIBLE
6	276081	2	GUAINA	GAINÉ	MANTEL	SHEATH	VAINA
7	207064	4	FASCETTA	COLLIER	HALTEBAND	CLAMP	ABRAZADERA
8	482148	3	TUBO FLESSIBILE	TUYAU FLEXIBLE	SCHLAUCH	FLEXIBLE HOSE	TUBO FLEXIBLE
9	410164	9	RACCORDO	RACCORD	ANSCHLUSS	FITTING	RACOR
10	409630	3	RACCORDO	RACCORD	ANSCHLUSS	FITTING	RACOR
11	124006	3	INNESTO RAPIDO	CONNECTION RAPIDE	SCHNELLKUPPLUNG	FAST COUPLING	CONEXION RAPIDA
12	288908	1	KIT TAPPO	KIT BOUCHON	VERSCHLUSSDECKELSATZ	PLUG KIT	KIT TAPON
13	482535	2	TUBO FLESSIBILE	TUYAU FLEXIBLE	SCHLAUCH	FLEXIBLE HOSE	TUBO FLEXIBLE
14	239268	2	RACCORDO	RACCORD	ANSCHLUSS	FITTING	RACOR
15	482538	1	TUBO FLESSIBILE	TUYAU FLEXIBLE	SCHLAUCH	FLEXIBLE HOSE	TUBO FLEXIBLE



COMPL. COMANDO 2° ATTIVAZIONE - RACCOGLITUBO (21024 - 23024 P)

* Compl. commande 2ème activation - serre-tubes
* 2. Aktivierung Steuerung - Ergänzung - Schlauchaufnahme
* 2nd activation control compl. - pipe holder
* Complet. mando 2º activación - recogetubo

TAV. SV.05.02

matr. G107.0005

21
23 P

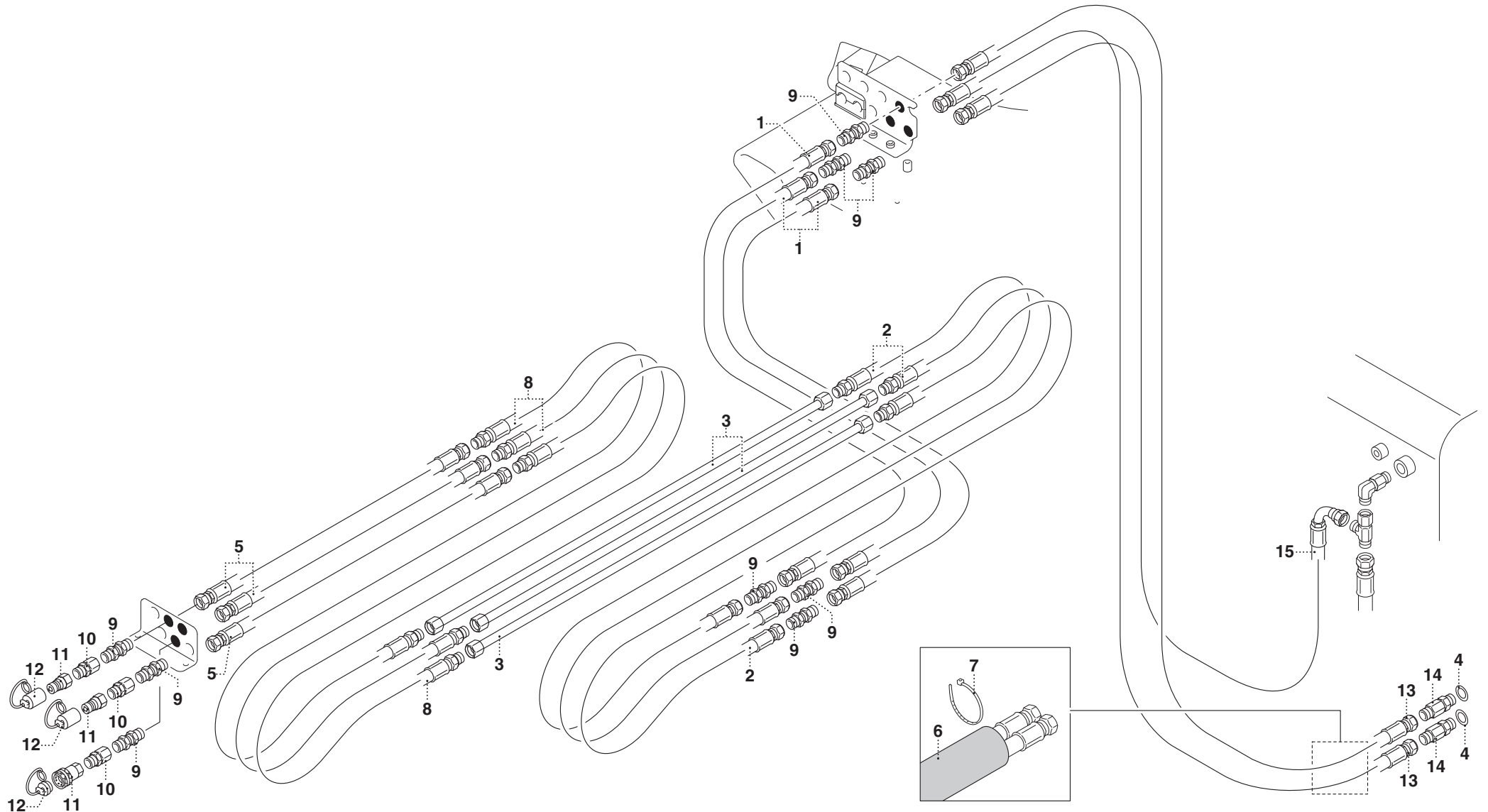

UN01-R-1694-MG

PM 21024 - PM 23024 P**matr. G107.0005****TAV. SV.05.02**

POS.	N° CODICE	Q.	DESCRIZIONE	DESIGNATION	BENENNUNG	DESCRIPTION	DENOMINACIONES
1	485847	3	TUBO FLESSIBILE	TUYAU FLEXIBLE	SCHLAUCH	FLEXIBLE HOSE	TUBO FLEXIBLE
2	482529	3	TUBO FLESSIBILE	TUYAU FLEXIBLE	SCHLAUCH	FLEXIBLE HOSE	TUBO FLEXIBLE
3	460181	3	TUBO RIGIDO	TUYAU RIGIDE	ROHR	PIPE	TUBO RIGIDO
4	417092	2	RONDELLA	RONDELLE	SCHEIBE	WASHER	ARANDELA
5	486138	3	TUBO FLESSIBILE	TUYAU FLEXIBLE	SCHLAUCH	FLEXIBLE HOSE	TUBO FLEXIBLE
6	276081	2	GUAINA	GAINÉ	MANTEL	SHEATH	VAINA
7	207064	4	FASCETTA	COLLIER	HALTEBAND	CLAMP	ABRAZADERA
8	482532	3	TUBO FLESSIBILE	TUYAU FLEXIBLE	SCHLAUCH	FLEXIBLE HOSE	TUBO FLEXIBLE
9	410164	9	RACCORDO	RACCORD	ANSCHLUSS	FITTING	RACOR
10	409630	3	RACCORDO	RACCORD	ANSCHLUSS	FITTING	RACOR
11	124006	3	INNESTO RAPIDO	CONNECTION RAPIDE	SCHNELLKUPPLUNG	FAST COUPLING	CONEXION RAPIDA
12	288908	1	KIT TAPPO	KIT BOUCHON	VERSCHLUSSDECKELSATZ	PLUG KIT	KIT TAPON
13	482535	2	TUBO FLESSIBILE	TUYAU FLEXIBLE	SCHLAUCH	FLEXIBLE HOSE	TUBO FLEXIBLE
14	239268	2	RACCORDO	RACCORD	ANSCHLUSS	FITTING	RACOR
15	482538	1	TUBO FLESSIBILE	TUYAU FLEXIBLE	SCHLAUCH	FLEXIBLE HOSE	TUBO FLEXIBLE



COMPL. COMANDO 2° ATTIVAZIONE - RACCOGLITUBO (21025 - 23025 P)

- * Compl. commande 2ème activation - serre-tubes
- * 2. Aktivierung Steuerung - Ergänzung - Schlauchaufnahme
- * 2nd activation control compl. - pipe holder
- * Complet. mando 2º activación - recogetubo

TAV. SV.05.03 1/2

matr. G107.0005

21
23 P

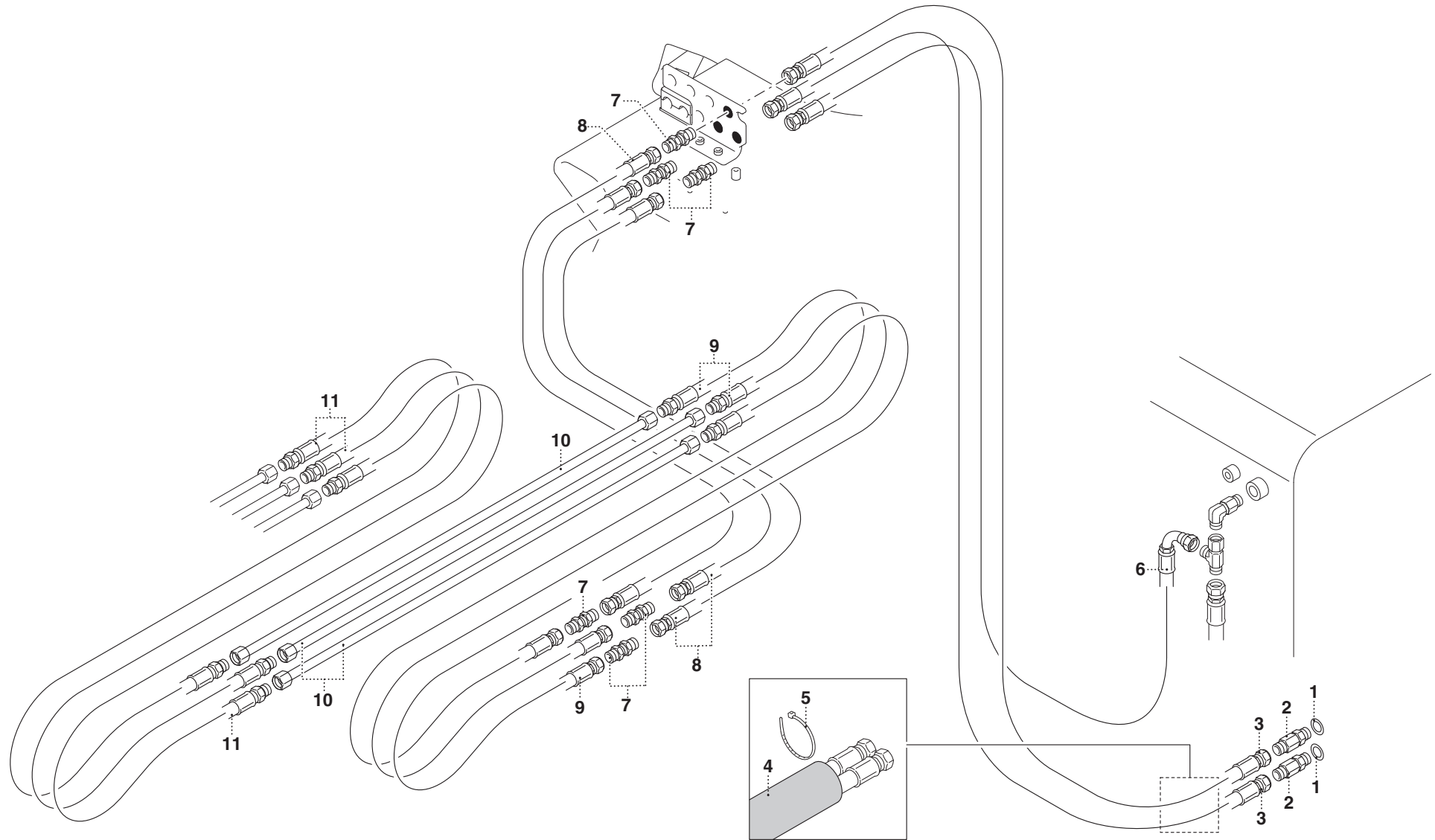



COMPL. COMANDO 2° ATTIVAZIONE - RACCOGLITUBO (21025 - 23025 P)

- * Compl. commande 2ème activation - serre-tubes
- * 2. Aktivierung Steuerung - Ergänzung - Schlauchaufnahme
- * 2nd activation control compl. - pipe holder
- * Complet. mando 2º activación - recogetubo

TAV. SV.05.03 2/2

matr. G107.0005

21
23 P

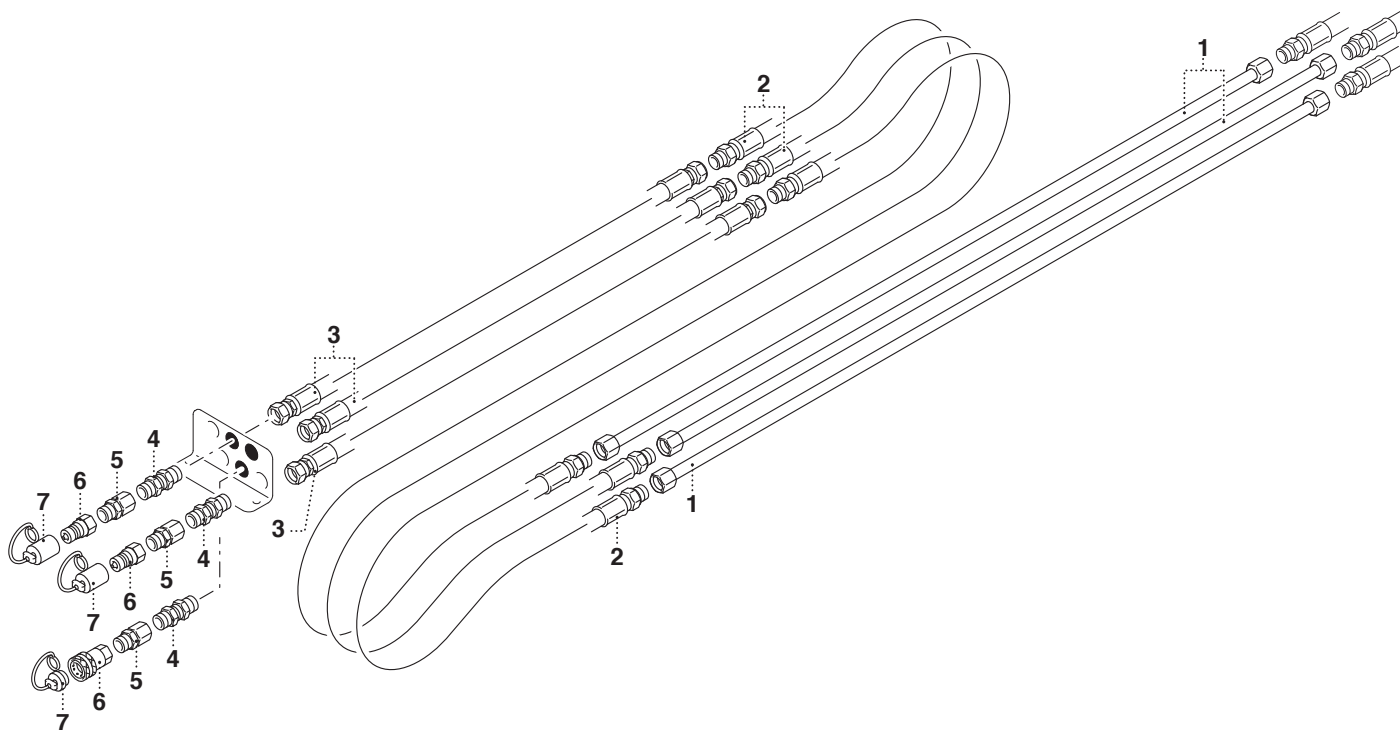

PM 21025 - PM 23025 P

matr. G107.0005

TAV. SV.05.03 2/2

POS.	N° CODICE	Q.	DESCRIZIONE	DESIGNATION	BENENNUNG	DESCRIPTION	DENOMINACIONES
1	460181	3	TUBO RIGIDO	TUYAU RIGIDE	ROHR	PIPE	TUBO RIGIDO
2	482148	3	TUBO FLESSIBILE	TUYAU FLEXIBLE	SCHLAUCH	FLEXIBLE HOSE	TUBO FLEXIBLE
3	485281	3	TUBO FLESSIBILE	TUYAU FLEXIBLE	SCHLAUCH	FLEXIBLE HOSE	TUBO FLEXIBLE
4	410164	3	RACCORDO	RACCORD	ANSCHLUSS	FITTING	RACOR
5	409630	3	RACCORDO	RACCORD	ANSCHLUSS	FITTING	RACOR
6	124006	3	INNESTO RAPIDO	CONNECTION RAPIDE	SCHNELLKUPPLUNG	FAST COUPLING	CONEXION RAPIDA
7	288908	3	KIT TAPPO	KIT BOUCHON	VERSCHLUSSDECKELSATZ	PLUG KIT	KIT TAPON



COMPL. COMANDO 2° ATTIVAZIONE - RACCOGLITUBO - 3° PUNTO DI MANOVRA (21023 - 23023 P)

- * Compl. commande 2ème activation - serre-tubes - 3ème point de manœuvre
- * 2. Aktivierung Steuerung - Ergänzung - Schlauchaufnahme - 3. Manöverplatz
- * 2nd activation control compl. - pipe holder - 3rd manoeuvre position
- * Complet. mando 2º activación - recogetubo - 3er punto de maniobra

TAV. SV.05.04

matr. G107.0005

21
23 P

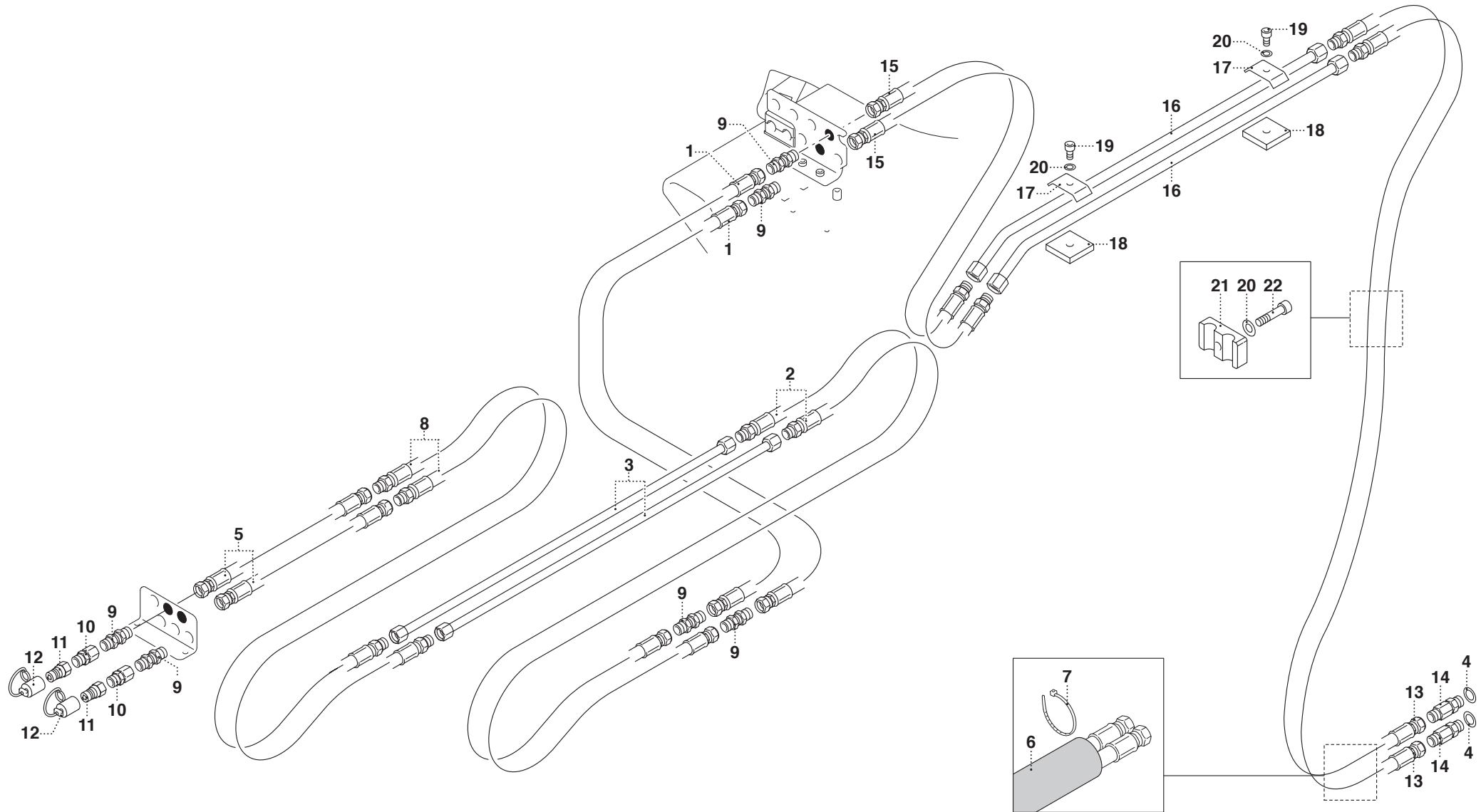

PM 21023 - PM 23023 P**matr. G107.0005****TAV. SV.05.04**

POS.	N° CODICE	Q.	DESCRIZIONE	DESIGNATION	BENENNUNG	DESCRIPTION	DENOMINACIONES
1	485847	2	TUBO FLESSIBILE	TUYAU FLEXIBLE	SCHLAUCH	FLEXIBLE HOSE	TUBO FLEXIBLE
2	482529	2	TUBO FLESSIBILE	TUYAU FLEXIBLE	SCHLAUCH	FLEXIBLE HOSE	TUBO FLEXIBLE
3	460180	2	TUBO RIGIDO	TUYAU RIGIDE	ROHR	PIPE	TUBO RIGIDO
4	417092	2	RONDELLA	RONDELLE	SCHEIBE	WASHER	ARANDELA
5	485281	2	TUBO FLESSIBILE	TUYAU FLEXIBLE	SCHLAUCH	FLEXIBLE HOSE	TUBO FLEXIBLE
6	276081	2	GUAINA	GAINÉ	MANTEL	SHEATH	VAINA
7	207064	4	FASCETTA	COLLIER	HALTEBAND	CLAMP	ABRAZADERA
8	482148	2	TUBO FLESSIBILE	TUYAU FLEXIBLE	SCHLAUCH	FLEXIBLE HOSE	TUBO FLEXIBLE
9	410164	6	RACCORDO	RACCORD	ANSCHLUSS	FITTING	RACOR
10	409630	2	RACCORDO	RACCORD	ANSCHLUSS	FITTING	RACOR
11	124006	2	INNESTO RAPIDO	CONNECTION RAPIDE	SCHNELLKUPPLUNG	FAST COUPLING	CONEXION RAPIDA
12	288908	1	KIT TAPPO	KIT BOUCHON	VERSCHLUSSDECKELSATZ	PLUG KIT	KIT TAPON
13	482603	2	TUBO FLESSIBILE	TUYAU FLEXIBLE	SCHLAUCH	FLEXIBLE HOSE	TUBO FLEXIBLE
14	239268	2	RACCORDO	RACCORD	ANSCHLUSS	FITTING	RACOR
15	482605	1	TUBO FLESSIBILE	TUYAU FLEXIBLE	SCHLAUCH	FLEXIBLE HOSE	TUBO FLEXIBLE
16	460339	2	TUBO RIGIDO	TUYAU RIGIDE	ROHR	PIPE	TUBO RIGIDO
17	353099	2	MORSETTO	ETAU	KLEMME	CLAMP	PRENSOR
18	292170	2	SPESSORE	EPAISSEUR	DICKE	THICKNESS	ESPEJOR
19	497132	2	VITE	VIS	SCHRAUBE	SCREW	TORNILLO
20	417025	3	RONDELLA	RONDELLE	SCHEIBE	WASHER	ARANDELA
21	353073	1	MORSETTO	ETAU	KLEMME	CLAMP	PRENSOR
22	497134	1	VITE	VIS	SCHRAUBE	SCREW	TORNILLO



COMPL. COMANDO 2° ATTIVAZIONE - RACCOGLITUBO - 3° PUNTO DI MANOVRA (21024 - 23024 P)

- * Compl. commande 2ème activation - serre-tubes - 3ème point de manœuvre
- * 2. Aktivierung Steuerung - Ergänzung - Schlauchaufnahme - 3. Manöverplatz
- * 2nd activation control compl. - pipe holder - 3rd manoeuvre position
- * Complet. mando 2º activación - recogetubo - 3er punto de maniobra

TAV. SV.05.05

matr. G107.0005

21
23 P

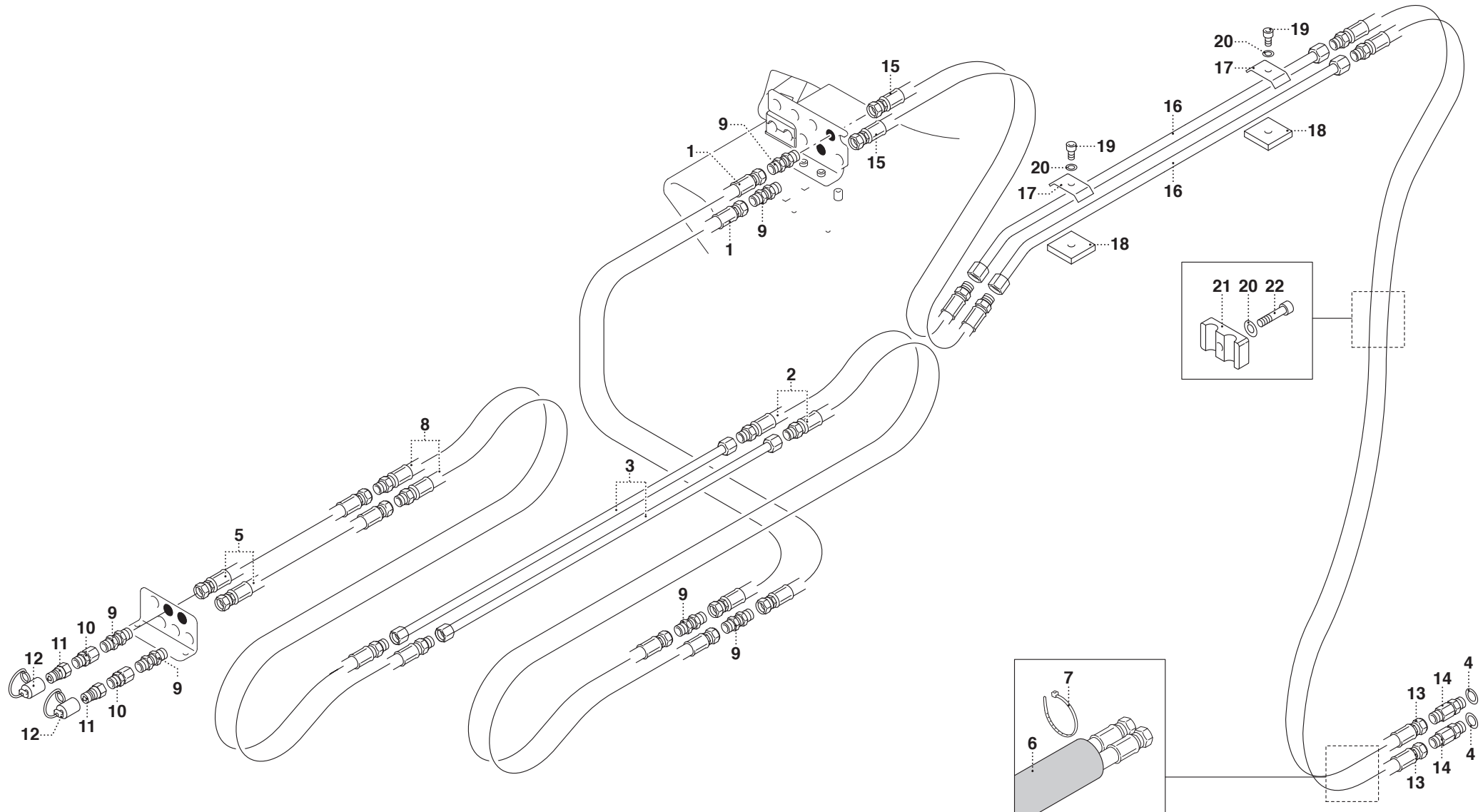

PM 21024 - PM 23024 P**matr. G107.0005****TAV. SV.05.05**

POS.	N° CODICE	Q.	DESCRIZIONE	DESIGNATION	BENENNUNG	DESCRIPTION	DENOMINACIONES
1	485847	2	TUBO FLESSIBILE	TUYAU FLEXIBLE	SCHLAUCH	FLEXIBLE HOSE	TUBO FLEXIBLE
2	482529	2	TUBO FLESSIBILE	TUYAU FLEXIBLE	SCHLAUCH	FLEXIBLE HOSE	TUBO FLEXIBLE
3	460181	2	TUBO RIGIDO	TUYAU RIGIDE	ROHR	PIPE	TUBO RIGIDO
4	417092	2	RONDELLA	RONDELLE	SCHEIBE	WASHER	ARANDELA
5	486138	2	TUBO FLESSIBILE	TUYAU FLEXIBLE	SCHLAUCH	FLEXIBLE HOSE	TUBO FLEXIBLE
6	276081	2	GUAINA	GAINÉ	MANTEL	SHEATH	VAINA
7	207064	4	FASCETTA	COLLIER	HALTEBAND	CLAMP	ABRAZADERA
8	482532	2	TUBO FLESSIBILE	TUYAU FLEXIBLE	SCHLAUCH	FLEXIBLE HOSE	TUBO FLEXIBLE
9	410164	6	RACCORDO	RACCORD	ANSCHLUSS	FITTING	RACOR
10	409630	2	RACCORDO	RACCORD	ANSCHLUSS	FITTING	RACOR
11	124006	2	INNESTO RAPIDO	CONNECTION RAPIDE	SCHNELLKUPPLUNG	FAST COUPLING	CONEXION RAPIDA
12	288908	1	KIT TAPPO	KIT BOUCHON	VERSCHLUSSDECKELSATZ	PLUG KIT	KIT TAPON
13	482603	2	TUBO FLESSIBILE	TUYAU FLEXIBLE	SCHLAUCH	FLEXIBLE HOSE	TUBO FLEXIBLE
14	239268	2	RACCORDO	RACCORD	ANSCHLUSS	FITTING	RACOR
15	482605	1	TUBO FLESSIBILE	TUYAU FLEXIBLE	SCHLAUCH	FLEXIBLE HOSE	TUBO FLEXIBLE
16	460339	2	TUBO RIGIDO	TUYAU RIGIDE	ROHR	PIPE	TUBO RIGIDO
17	353099	2	MORSETTO	ETAU	KLEMME	CLAMP	PRENSOR
18	292170	2	SPESSORE	EPAISSEUR	DICKE	THICKNESS	ESPEJOR
19	497132	2	VITE	VIS	SCHRAUBE	SCREW	TORNILLO
20	417025	3	RONDELLA	RONDELLE	SCHEIBE	WASHER	ARANDELA
21	353073	1	MORSETTO	ETAU	KLEMME	CLAMP	PRENSOR
22	497134	1	VITE	VIS	SCHRAUBE	SCREW	TORNILLO



COMPL. COMANDO 2° ATTIVAZIONE - RACCOGLITUBO - 3° PUNTO DI MANOVRA (21025 - 23025 P)

- * Compl. commande 2ème activation - serre-tubes - 3ème point de manoeuvre
- * 2. Aktivierung Steuerung - Ergänzung - Schlauchaufnahme - 3. Manöverplatz
- * 2nd activation control compl. - pipe holder - 3rd manoeuvre position
- * Complet. mando 2º activación - recogetubo - 3er punto de maniobra

TAV. SV.05.06

matr. G107.0005

21
23 P

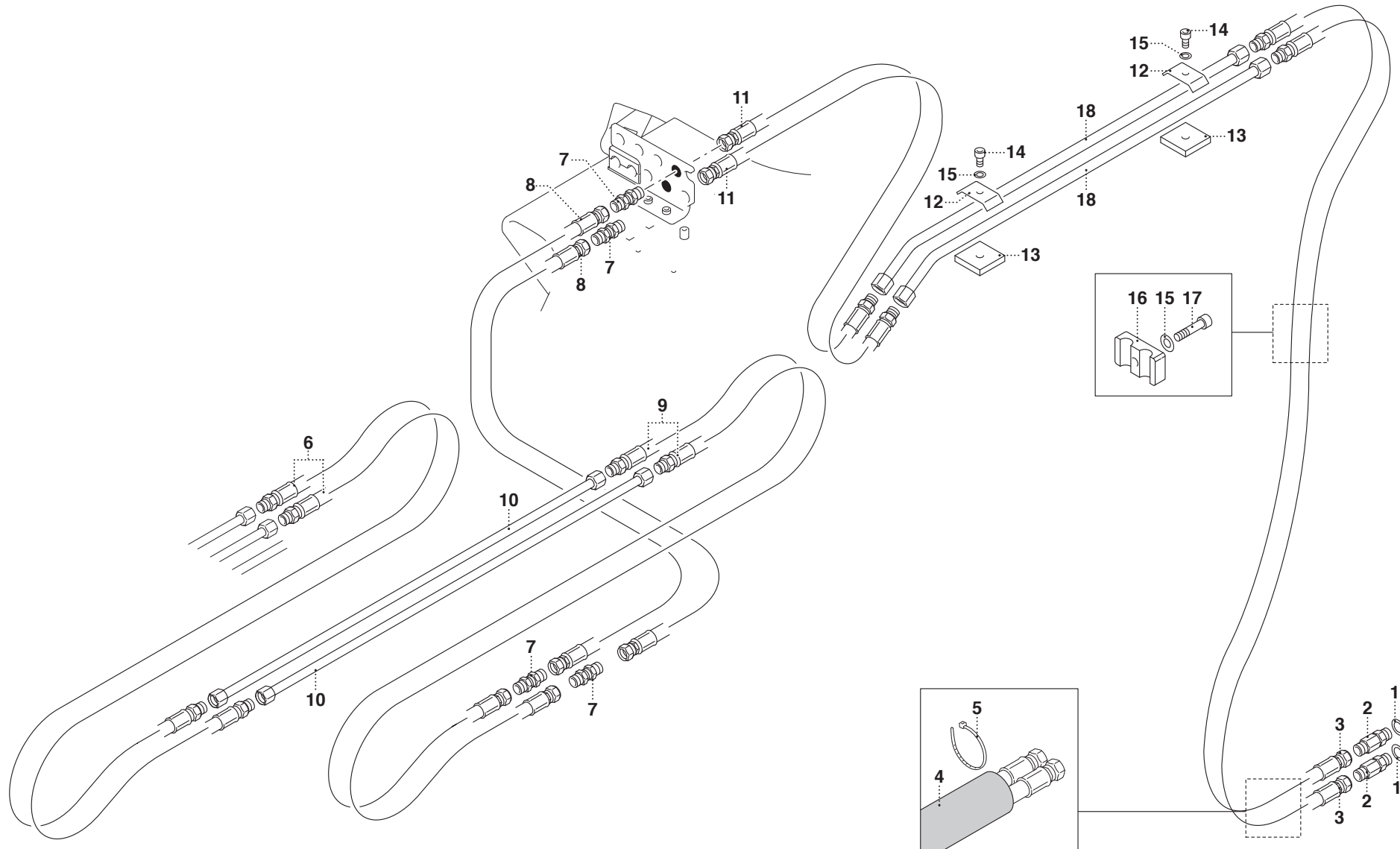

PM 21025 - PM 23025 P**matr. G107.0005****TAV. SV.05.06**

POS.	N° CODICE	Q.	DESCRIZIONE	DESIGNATION	BENENNUNG	DESCRIPTION	DENOMINACIONES
1	417092	2	RONDELLA	RONDELLE	SCHEIBE	WASHER	ARANDELA
2	239268	2	RACCORDO	RACCORD	ANSCHLUSS	FITTING	RACOR
3	482603	2	TUBO FLESSIBILE	TUYAU FLEXIBLE	SCHLAUCH	FLEXIBLE HOSE	TUBO FLEXIBLE
4	276081	2	GUAINA	GAINÉ	MANTEL	SHEATH	VAINA
5	207064	4	FASCETTA	COLLIER	HALTEBAND	CLAMP	ABRAZADERA
6	482532	2	TUBO FLESSIBILE	TUYAU FLEXIBLE	SCHLAUCH	FLEXIBLE HOSE	TUBO FLEXIBLE
7	410164	4	RACCORDO	RACCORD	ANSCHLUSS	FITTING	RACOR
8	485847	2	TUBO FLESSIBILE	TUYAU FLEXIBLE	SCHLAUCH	FLEXIBLE HOSE	TUBO FLEXIBLE
9	482529	2	TUBO FLESSIBILE	TUYAU FLEXIBLE	SCHLAUCH	FLEXIBLE HOSE	TUBO FLEXIBLE
10	460180	2	TUBO RIGIDO	TUYAU RIGIDE	ROHR	PIPE	TUBO RIGIDO
11	482605	1	TUBO FLESSIBILE	TUYAU FLEXIBLE	SCHLAUCH	FLEXIBLE HOSE	TUBO FLEXIBLE
12	353099	2	MORSETTO	ETAU	KLEMME	CLAMP	PRENSOR
13	292170	2	SPESSORE	EPAISSEUR	DICKE	THICKNESS	ESPEJOR
14	497132	2	VITE	VIS	SCHRAUBE	SCREW	TORNILLO
15	417025	3	RONDELLA	RONDELLE	SCHEIBE	WASHER	ARANDELA
16	353073	1	MORSETTO	ETAU	KLEMME	CLAMP	PRENSOR
17	497134	1	VITE	VIS	SCHRAUBE	SCREW	TORNILLO
18	460339	2	TUBO RIGIDO	TUYAU RIGIDE	ROHR	PIPE	TUBO RIGIDO



COMPL. ATTIVAZIONE - RACCOGLITUBO (LC)

- * Compl. activation - serre-tubes (LC)
- * Aktivierung - Ergänzung - Schlauchaufnahme (LC)
- * Activation compl. - pipe holder (LC)
- * Complet. activación - recogetubo (LC)

TAV. SV.06.01

matr. G107.0005

21
23 P

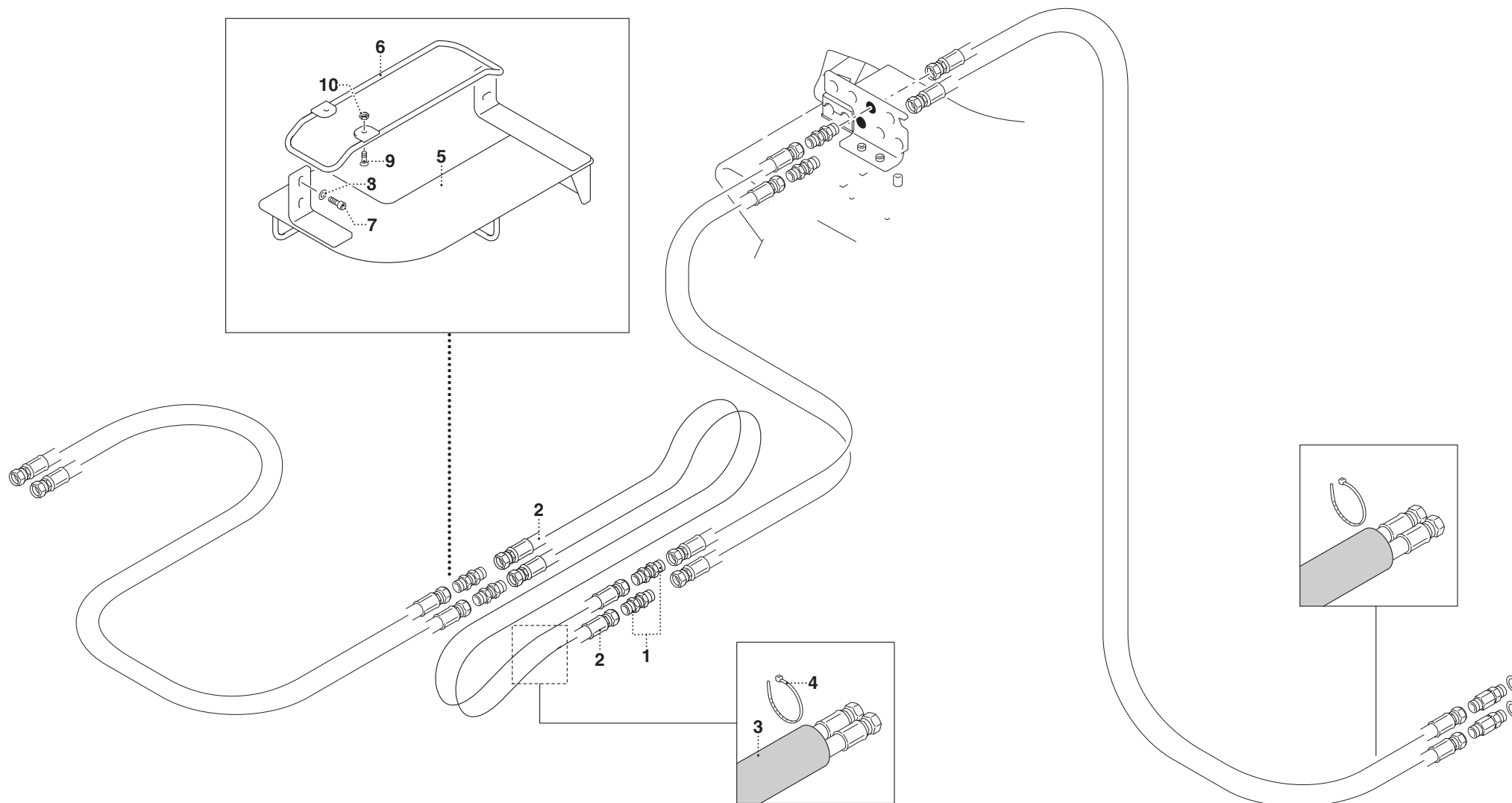



COMANDO ATTIVAZIONE ARGANO TC1 - TC2 (23 P)

- * *Comande activation treuil - TC1-TC2*
- * *Winde Betätigungssteuerung - TC1-TC2*
- * *Winch activation control - TC1-TC2*
- * *Mando activación cabrestante - TC1-TC2*

TAV. SV.07.01

matr. G107.0005

21
23 P

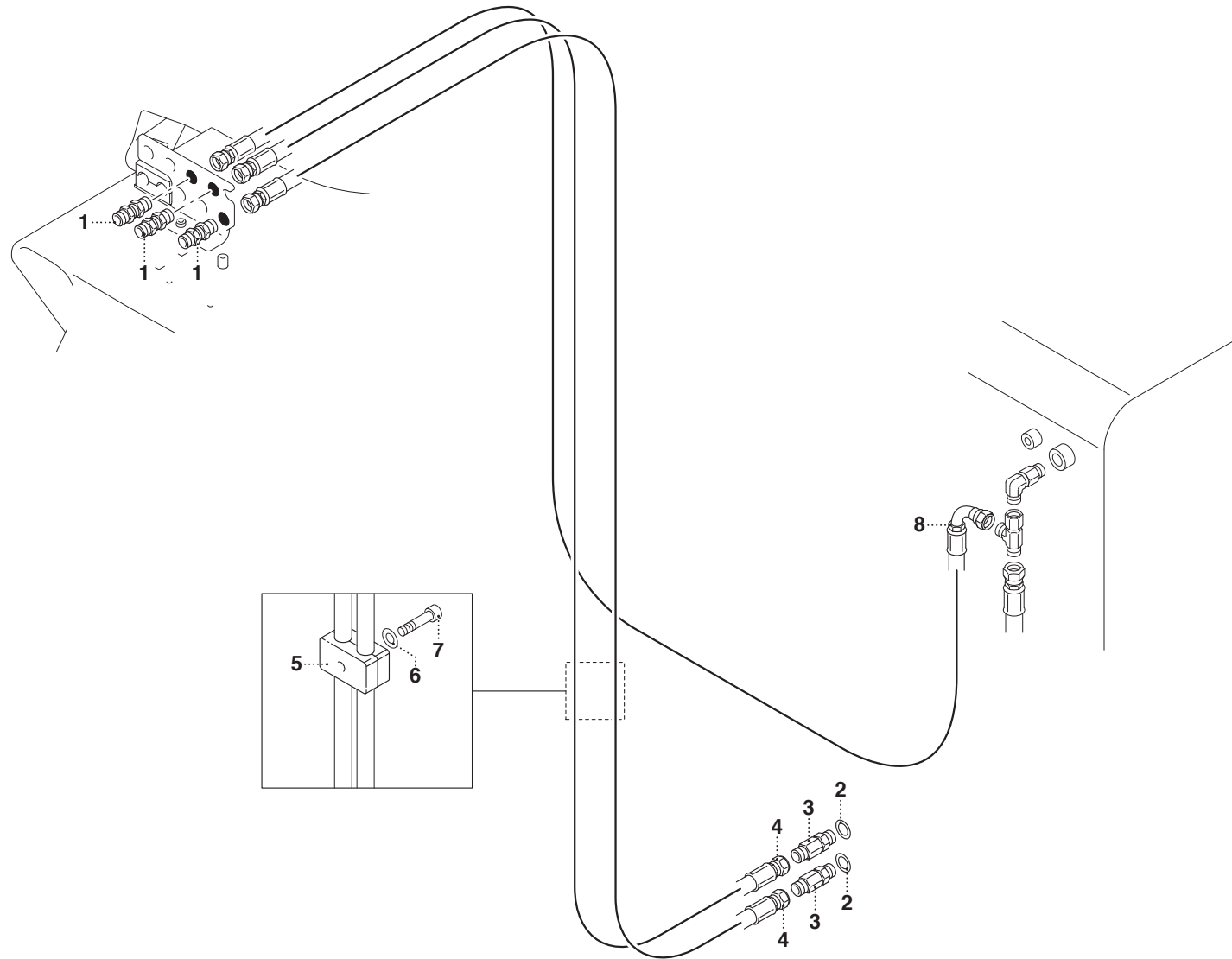

PM 23 P

matr. G107.0005

TAV. SV.07.01

POS.	N° CODICE	Q.	DESCRIZIONE	DESIGNATION	BENENNUNG	DESCRIPTION	DENOMINACIONES
1	410164	3	RACCORDO	RACCORD	ANSCHLUSS	FITTING	RACOR
2	417092	2	RONDELLA	RONDELLE	SCHEIBE	WASHER	ARANDELA
3	239268	2	RACCORDO	RACCORD	ANSCHLUSS	FITTING	RACOR
4	482535	2	TUBO FLESSIBILE	TUYAU FLEXIBLE	SCHLAUCH	FLEXIBLE HOSE	TUBO FLEXIBLE
5	353073	1	MORSETTO	ETAU	KLEMME	CLAMP	PRENSOR
6	417025	1	RONDELLA	RONDELLE	SCHEIBE	WASHER	ARANDELA
7	497134	1	VITE	VIS	SCHRAUBE	SCREW	TORNILLO
8	482538	1	TUBO FLESSIBILE	TUYAU FLEXIBLE	SCHLAUCH	FLEXIBLE HOSE	TUBO FLEXIBLE



COMANDO ATTIVAZIONE ARGANO P15 (21)

- * *Commande activation treuil - P15*
- * *Winde Betätigungssteuerung - P15*
- * *Winch activation control - P15*
- * *Mando activación cabrestante - P15*

TAV. SV.07.02

matr. G107.0005

21
23 P

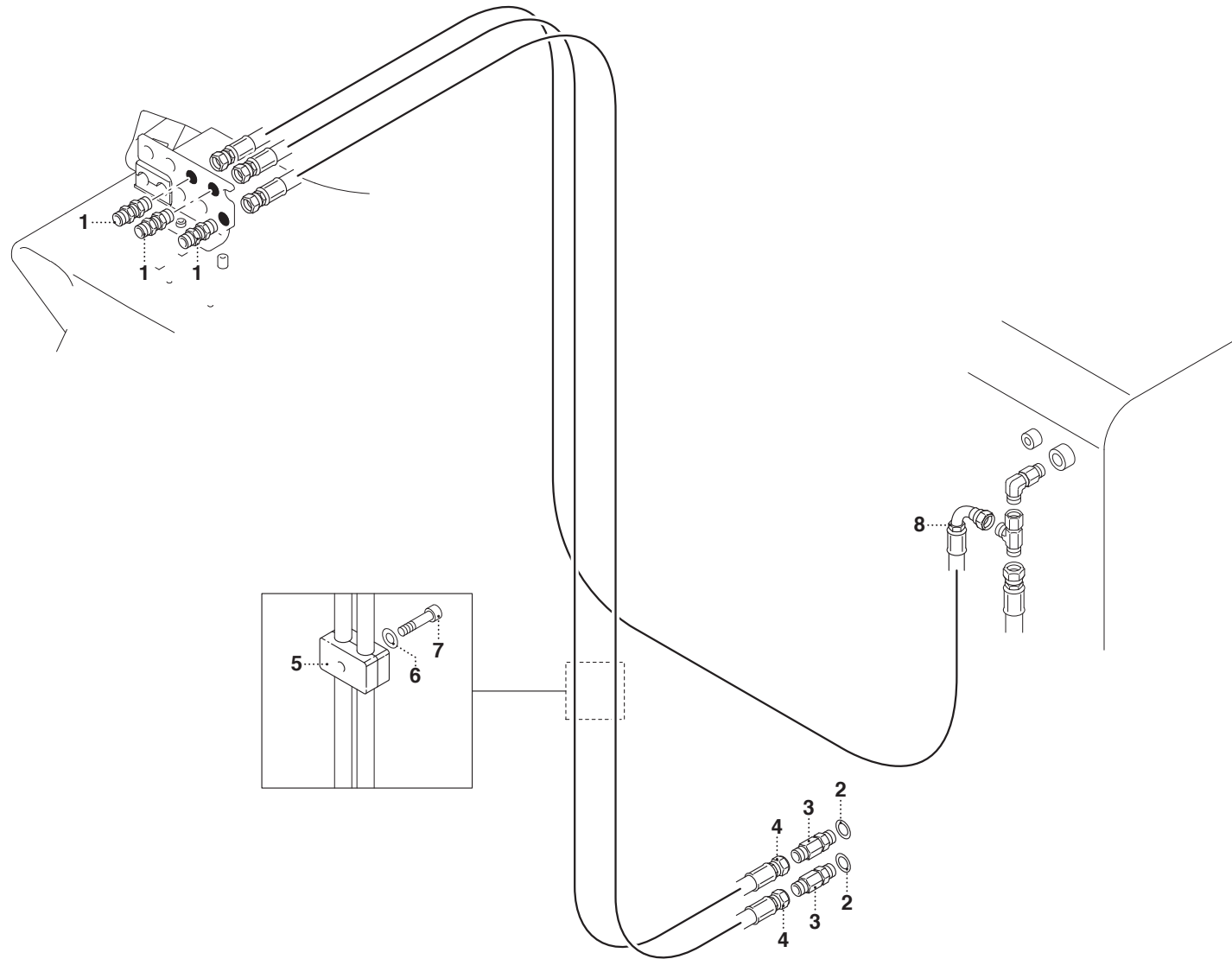



COMPL. IMPIANTO ARGANO TC1 (STANDARD) (23 P)

- * Compl. installation treuil - TC1 (standard)
- * Winde Anlagebetätigung - TC1 (Standard)
- * Winch system completion - TC1 (standard)
- * Complet. instalación cabrestante TC1 (estándar)

TAV. SV.08.01

matr. G107.0005

21
23 P

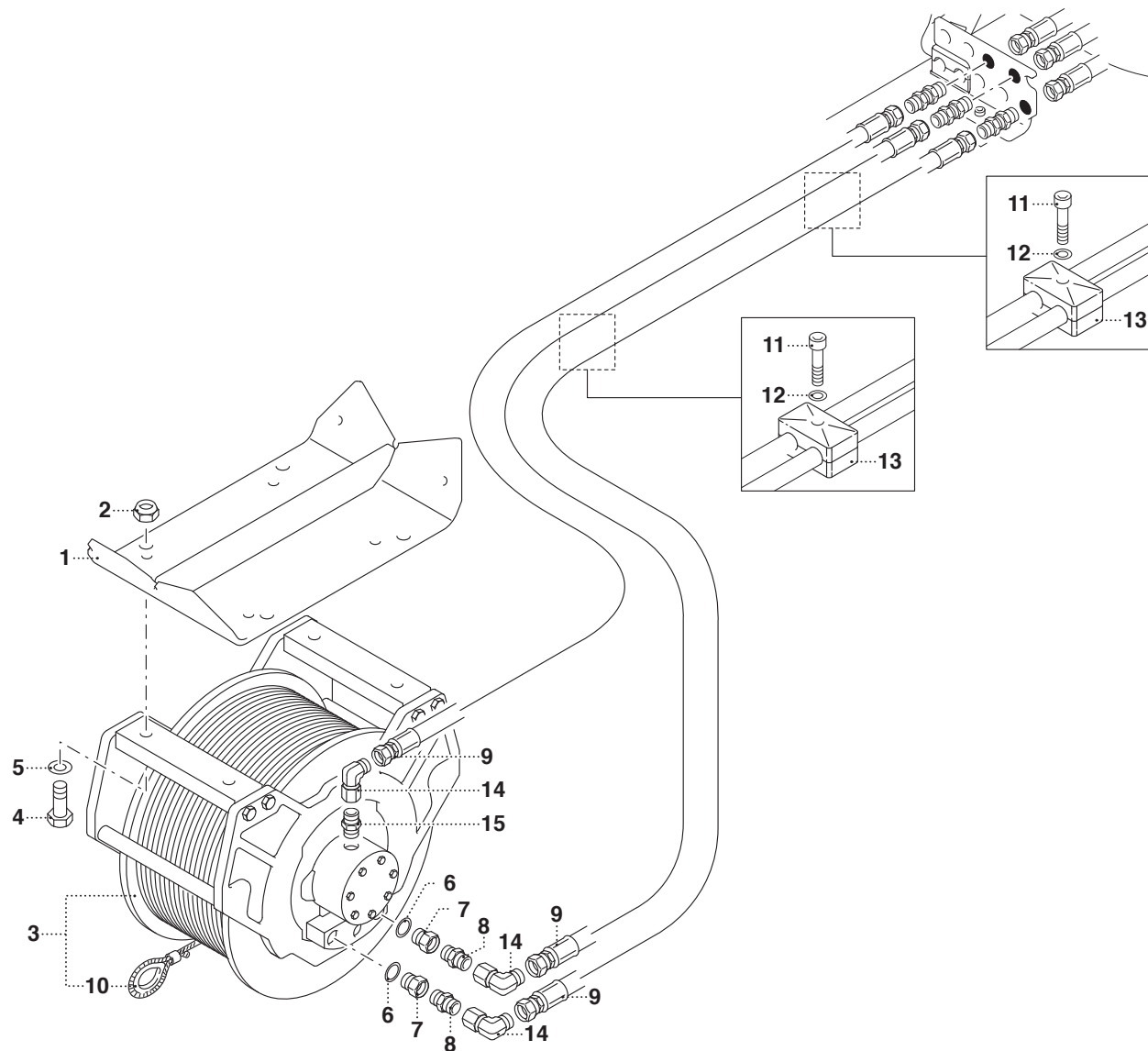

PM 23 P**matr. G107.0005****TAV. SV.08.01**

POS.	N° CODICE	Q.	DESCRIZIONE	DESIGNATION	BENENNUNG	DESCRIPTION	DENOMINACIONES
1	467602	1	SUPPORTO	SUPPORT	TRÄGER	SUPPORT	SOPORTE
2	191095	4	DADO	ECROU	MUTTER	NUT	TUERCA
3	119067	1	ARGANO	TREUIL	WINDE	WINCH	CABRESTANTE
4	497165	4	VITE	VIS	SCHRAUBE	SCREW	TORNILLO
5	417027	4	RONDELLA	RONDELLE	SCHEIBE	WASHER	ARANDELA
6	417093	2	RONDELLA	RONDELLE	SCHEIBE	WASHER	ARANDELA
7	409669	2	RACCORDO	RACCORD	ANSCHLUSS	FITTING	RACOR
8	409632	2	RACCORDO	RACCORD	ANSCHLUSS	FITTING	RACOR
9	485847	3	TUBO FLESSIBILE	TUYAU FLEXIBLE	SCHLAUCH	FLEXIBLE HOSE	TUBO FLEXIBLE
10	227019	1	CAVO	CABLE	KABEL	CABLE	TORNILLO
11	497134	2	VITE	VIS	SCHRAUBE	SCREW	PRENSOR
12	417025	2	RONDELLA	RONDELLE	SCHEIBE	WASHER	ARANDELA
13	353073	2	MORSETTO	ETAU	KLEMME	CLAMP	TORNILLO
14	409633	3	RACCORDO	RACCORD	ANSCHLUSS	FITTING	RACOR
15	409634	1	RACCORDO	RACCORD	ANSCHLUSS	FITTING	RACOR



COMPL. IMPIANTO ARGANO TC1 (LC) (23 P)

- * Compl. installation treuil - TC1 (LC)
- * Winde Anlagebetätigung - TC1 (LC)
- * Winch system completion - TC1 (LC)
- * Complet. instalación cabrestante TC1 (LC)

TAV. SV.08.02

matr. G107.0005

21
23 P

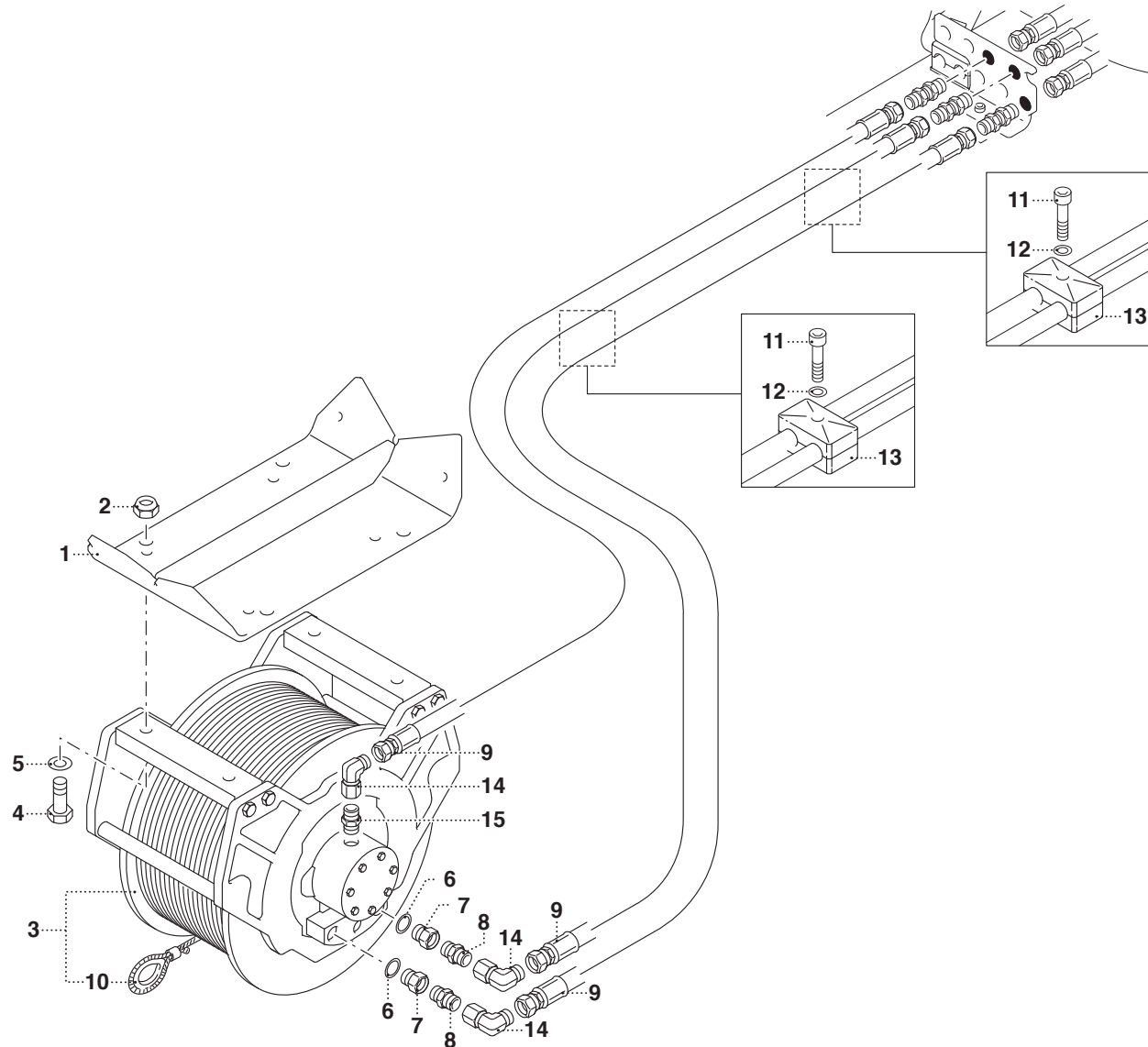

PM 23 P LC**matr. G107.0005****TAV. SV.08.02**

POS.	N° CODICE	Q.	DESCRIZIONE	DESIGNATION	BENENNUNG	DESCRIPTION	DENOMINACIONES
1	467605	1	SUPPORTO	SUPPORT	TRÄGER	SUPPORT	SOPORTE
2	191095	4	DADO	ECROU	MUTTER	NUT	TUERCA
3	119067	1	ARGANO	TREUIL	WINDE	WINCH	CABRESTANTE
4	497165	4	VITE	VIS	SCHRAUBE	SCREW	TORNILLO
5	417027	4	RONDELLA	RONDELLE	SCHEIBE	WASHER	ARANDELA
6	417093	2	RONDELLA	RONDELLE	SCHEIBE	WASHER	ARANDELA
7	409669	2	RACCORDO	RACCORD	ANSCHLUSS	FITTING	RACOR
8	409632	2	RACCORDO	RACCORD	ANSCHLUSS	FITTING	RACOR
9	485847	3	TUBO FLESSIBILE	TUYAU FLEXIBLE	SCHLAUCH	FLEXIBLE HOSE	TUBO FLEXIBLE
10	227019	1	CAVO	CABLE	KABEL	CABLE	CABLE
11	497134	2	VITE	VIS	SCHRAUBE	SCREW	TORNILLO
12	417025	2	RONDELLA	RONDELLE	SCHEIBE	WASHER	ARANDELA
13	353073	2	MORSETTO	ETAU	KLEMME	CLAMP	PRENSOR
14	409633	3	RACCORDO	RACCORD	ANSCHLUSS	FITTING	RACOR
15	409634	1	RACCORDO	RACCORD	ANSCHLUSS	FITTING	RACOR



COMPL. IMPIANTO ARGANO TC2 (STANDARD) (23 P)

- * Compl. installation treuil - TC2 (standard)
- * Winde Anlagebetätigung - TC2 (Standard)
- * Winch system completion - TC2 (standard)
- * Complet. instalación cabrestante TC2 (estándar)

TAV. SV.09.01

matr. G107.0005

21
23 P

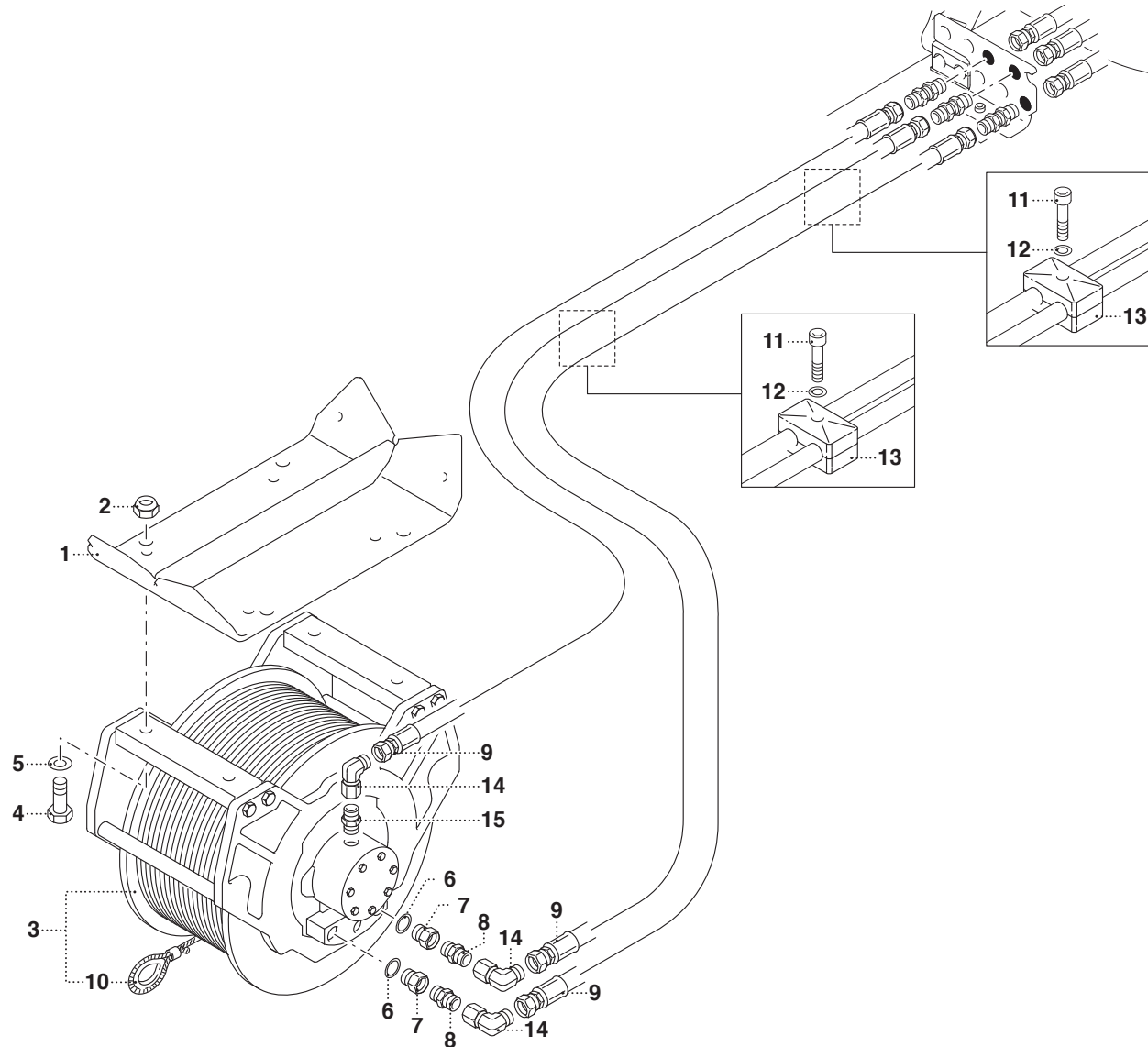

PM 23 P**matr. G107.0005****TAV. SV.09.01**

POS.	N° CODICE	Q.	DESCRIZIONE	DESIGNATION	BENENNUNG	DESCRIPTION	DENOMINACIONES
1	467602	1	SUPPORTO	SUPPORT	TRÄGER	SUPPORT	SOPORTE
2	191095	4	DADO	ECROU	MUTTER	NUT	TUERCA
3	119074	1	ARGANO	TREUIL	WINDE	WINCH	CABRESTANTE
4	497165	4	VITE	VIS	SCHRAUBE	SCREW	TORNILLO
5	417027	4	RONDELLA	RONDELLE	SCHEIBE	WASHER	ARANDELA
6	417093	2	RONDELLA	RONDELLE	SCHEIBE	WASHER	ARANDELA
7	409669	2	RACCORDO	RACCORD	ANSCHLUSS	FITTING	RACOR
8	409632	2	RACCORDO	RACCORD	ANSCHLUSS	FITTING	RACOR
9	485847	3	TUBO FLESSIBILE	TUYAU FLEXIBLE	SCHLAUCH	FLEXIBLE HOSE	TUBO FLEXIBLE
10	227055	1	CAVO	CABLE	KABEL	CABLE	CABLE
11	497134	2	VITE	VIS	SCHRAUBE	SCREW	TORNILLO
12	417025	2	RONDELLA	RONDELLE	SCHEIBE	WASHER	ARANDELA
13	353073	2	MORSETTO	ETAU	KLEMME	CLAMP	PRENSOR
14	409633	3	RACCORDO	RACCORD	ANSCHLUSS	FITTING	RACOR
15	409634	1	RACCORDO	RACCORD	ANSCHLUSS	FITTING	RACOR



COMPL. IMPIANTO ARGANO TC2 (LC) (21)

- * Compl. installation treuil - TC2 (LC)
- * Winde Anlagebetätigung - TC2 (LC)
- * Winch system completion - TC2 (LC)
- * Complet. instalación cabrestante TC2 (LC)

TAV. SV.09.02

matr. G107.0005

21
23 P

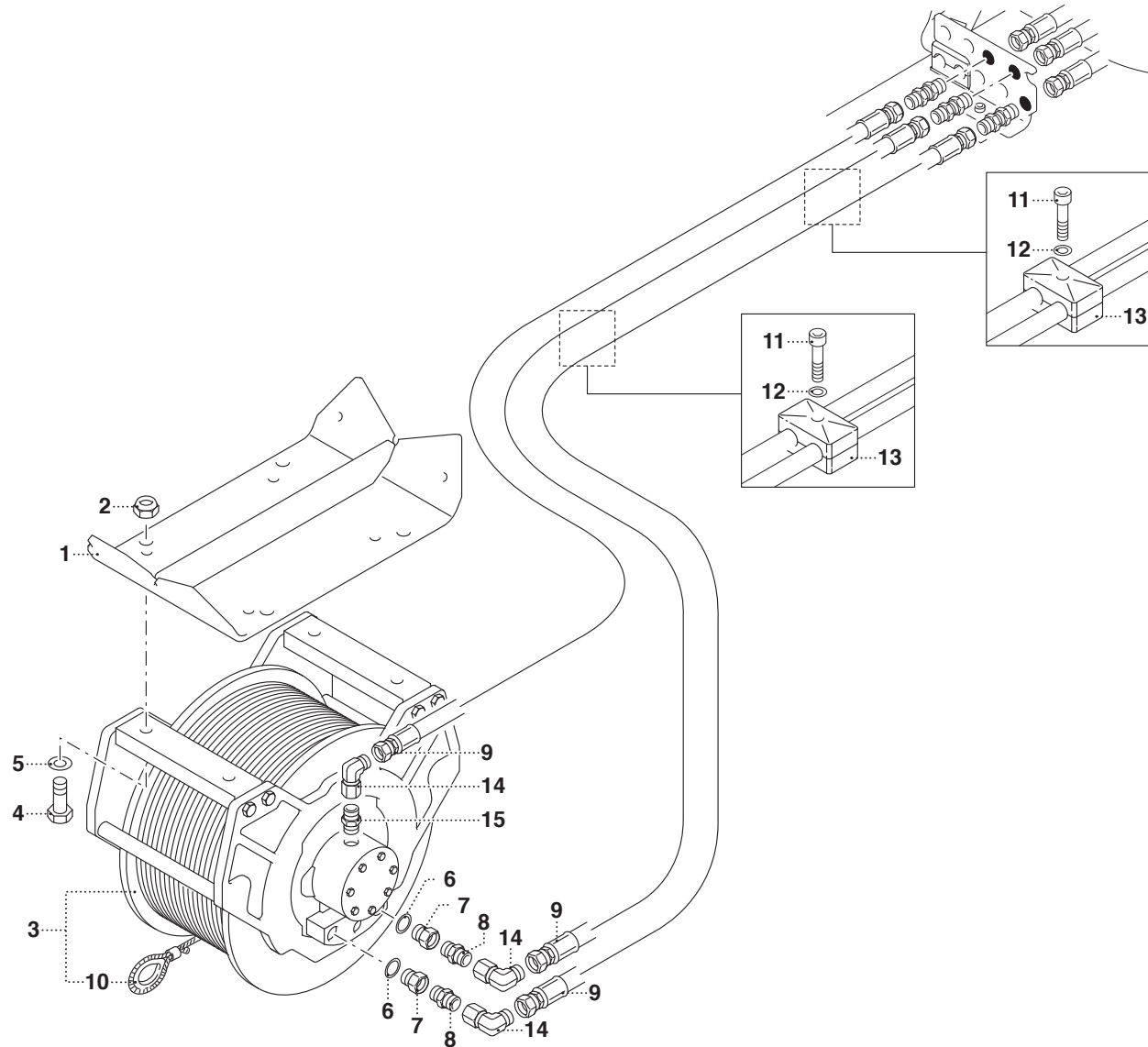

PM 21 LC**matr. G107.0005****TAV. SV.09.02**

POS.	N° CODICE	Q.	DESCRIZIONE	DESIGNATION	BENENNUNG	DESCRIPTION	DENOMINACIONES
1	467605	1	SUPPORTO	SUPPORT	TRÄGER	SUPPORT	SOPORTE
2	191095	4	DADO	ECROU	MUTTER	NUT	TUERCA
3	119074	1	ARGANO	TREUIL	WINDE	WINCH	CABRESTANTE
4	497165	4	VITE	VIS	SCHRAUBE	SCREW	TORNILLO
5	417027	4	RONDELLA	RONDELLE	SCHEIBE	WASHER	ARANDELA
6	417093	2	RONDELLA	RONDELLE	SCHEIBE	WASHER	ARANDELA
7	409669	2	RACCORDO	RACCORD	ANSCHLUSS	FITTING	RACOR
8	409632	2	RACCORDO	RACCORD	ANSCHLUSS	FITTING	RACOR
9	485847	3	TUBO FLESSIBILE	TUYAU FLEXIBLE	SCHLAUCH	FLEXIBLE HOSE	TUBO FLEXIBLE
10	227055	1	CAVO	CABLE	KABEL	CABLE	CABLE
11	497134	2	VITE	VIS	SCHRAUBE	SCREW	TORNILLO
12	417025	2	RONDELLA	RONDELLE	SCHEIBE	WASHER	ARANDELA
13	353073	2	MORSETTO	ETAU	KLEMME	CLAMP	PRENSOR
14	409633	3	RACCORDO	RACCORD	ANSCHLUSS	FITTING	RACOR
15	409634	1	RACCORDO	RACCORD	ANSCHLUSS	FITTING	RACOR



COMPL. IMPIANTO ARGANO P15 (21)

- * Compl. installation treuil - P15
- * Winde Anlagebetätigung - P15
- * Winch system completion - P15
- * Complet. instalación cabrestante - P15

TAV. SV.09.03

matr. G107.0005

21
23 P

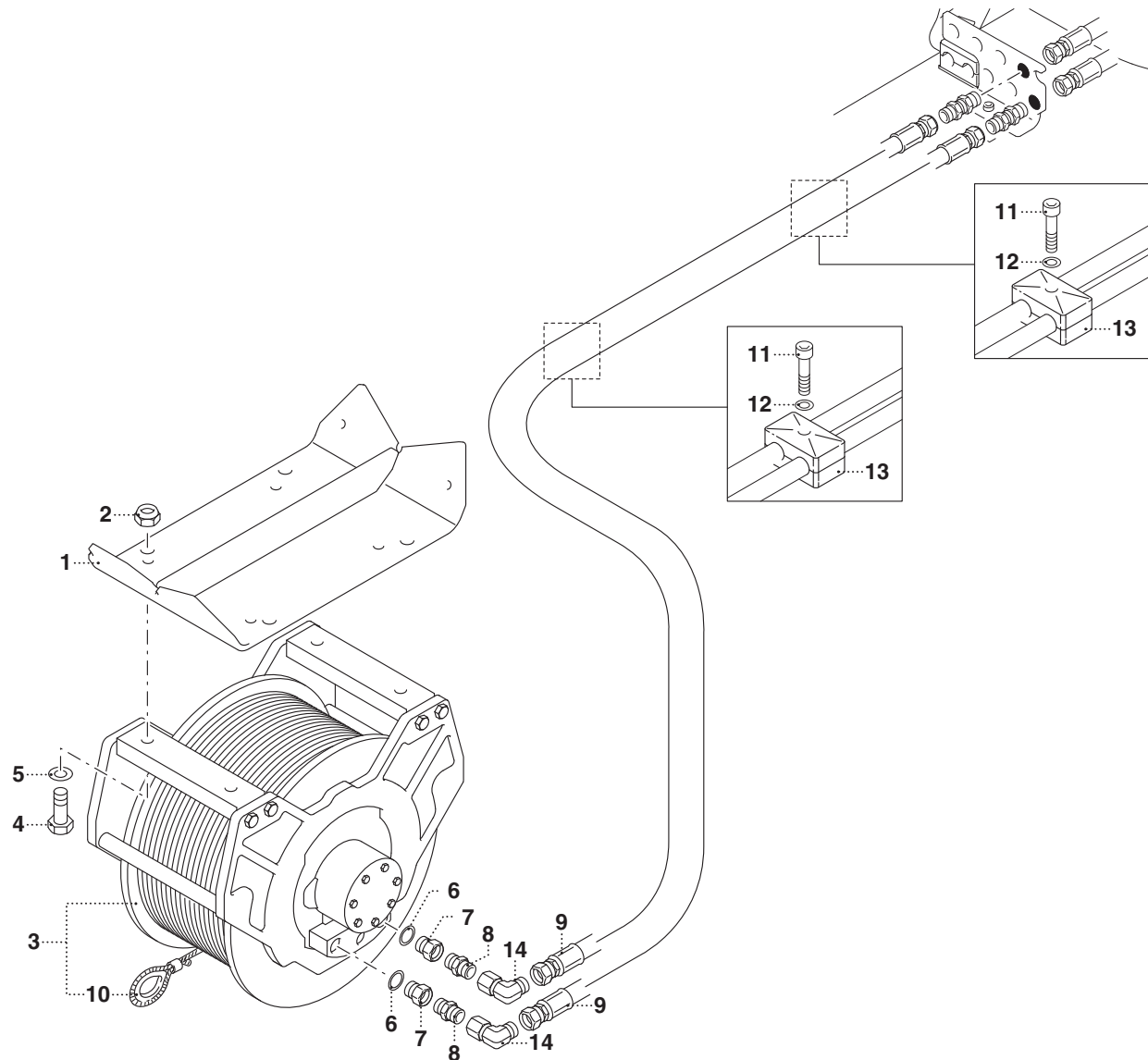

PM 21**matr. G107.0005****TAV. SV.09.03**

POS.	N° CODICE	Q.	DESCRIZIONE	DESIGNATION	BENENNUNG	DESCRIPTION	DENOMINACIONES
1	467602	1	SUPPORTO	SUPPORT	TRÄGER	SUPPORT	SOPORTE
2	191160	4	DADO	ECROU	MUTTER	NUT	TUERCA
3	119028	1	ARGANO	TREUIL	WINDE	WINCH	CABRESTANTE
4	497060	4	VITE	VIS	SCHRAUBE	SCREW	TORNILLO
5	417028	4	RONDELLA	RONDELLE	SCHEIBE	WASHER	ARANDELA
6	417093	2	RONDELLA	RONDELLE	SCHEIBE	WASHER	ARANDELA
7	409669	2	RACCORDO	RACCORD	ANSCHLUSS	FITTING	RACOR
8	409632	2	RACCORDO	RACCORD	ANSCHLUSS	FITTING	RACOR
9	485847	3	TUBO FLESSIBILE	TUYAU FLEXIBLE	SCHLAUCH	FLEXIBLE HOSE	TUBO FLEXIBLE
10	227031	1	CAVO	CABLE	KABEL	CABLE	CABLE
11	497134	2	VITE	VIS	SCHRAUBE	SCREW	TORNILLO
12	417025	2	RONDELLA	RONDELLE	SCHEIBE	WASHER	ARANDELA
13	353073	2	MORSETTO	ETAU	KLEMME	CLAMP	PRENSOR
14	409633	3	RACCORDO	RACCORD	ANSCHLUSS	FITTING	RACOR



COMPL. IMPIANTO ARGANO P15 (LC) (21)

- * Compl. installation treuil - P15 (LC)
- * Winde Anlagebetätigung - P15 (LC)
- * Winch system completion - P15 (LC)
- * Complet. instalación cabrestante - P15 (LC)

TAV. SV.09.04

matr. G107.0005

21
23 P

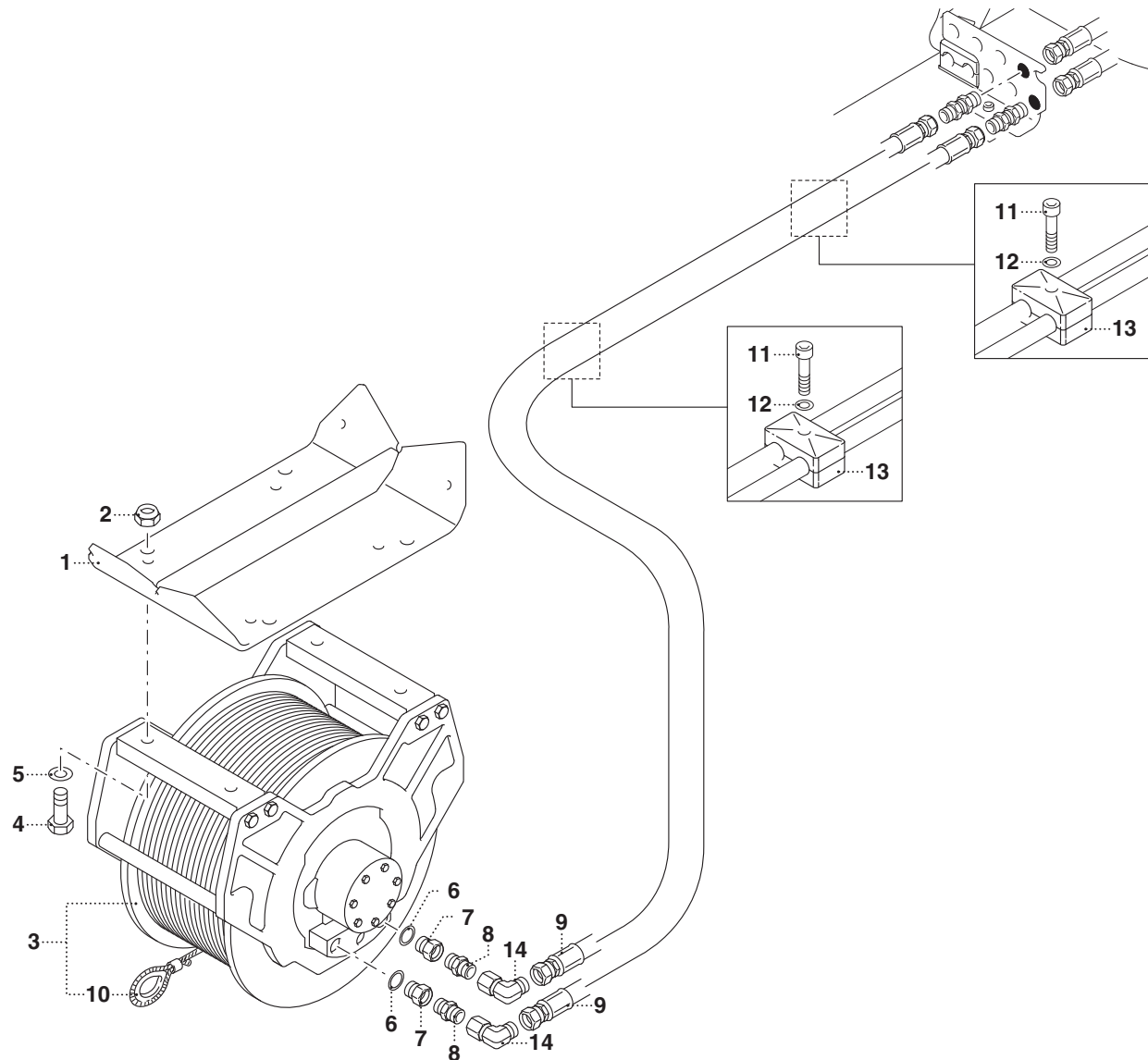

PM 21**matr. G107.0005****TAV. SV.09.04**

POS.	N° CODICE	Q.	DESCRIZIONE	DESIGNATION	BENENNUNG	DESCRIPTION	DENOMINACIONES
1	467605	1	SUPPORTO	SUPPORT	TRÄGER	SUPPORT	SOPORTE
2	191160	4	DADO	ECROU	MUTTER	NUT	TUERCA
3	119028	1	ARGANO	TREUIL	WINDE	WINCH	CABRESTANTE
4	497060	4	VITE	VIS	SCHRAUBE	SCREW	TORNILLO
5	417028	4	RONDELLA	RONDELLE	SCHEIBE	WASHER	ARANDELA
6	417093	2	RONDELLA	RONDELLE	SCHEIBE	WASHER	ARANDELA
7	409669	2	RACCORDO	RACCORD	ANSCHLUSS	FITTING	RACOR
8	409632	2	RACCORDO	RACCORD	ANSCHLUSS	FITTING	RACOR
9	485847	2	TUBO FLESSIBILE	TUYAU FLEXIBLE	SCHLAUCH	FLEXIBLE HOSE	TUBO FLEXIBLE
10	227031	1	CAVO	CABLE	KABEL	CABLE	CABLE
11	497134	2	VITE	VIS	SCHRAUBE	SCREW	TORNILLO
12	417025	2	RONDELLA	RONDELLE	SCHEIBE	WASHER	ARANDELA
13	353073	2	MORSETTO	ETAU	KLEMME	CLAMP	PRENSOR
14	409633	2	RACCORDO	RACCORD	ANSCHLUSS	FITTING	RACOR



BOZZELLO TC1 (2 TIRI) (23 P)

- * Poulie TC1 (2 tractions)
- * TC1 Seilblock (2 Züge)
- * TC1 line block (2 pulls)
- * Poleas TC1 (2 tiros)

TAV. SV.10.01

matr. G107.0005

21
23 P

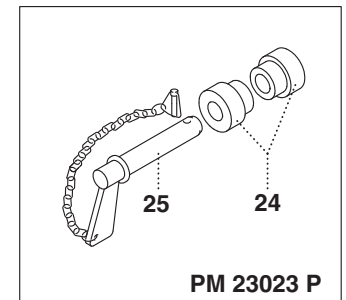
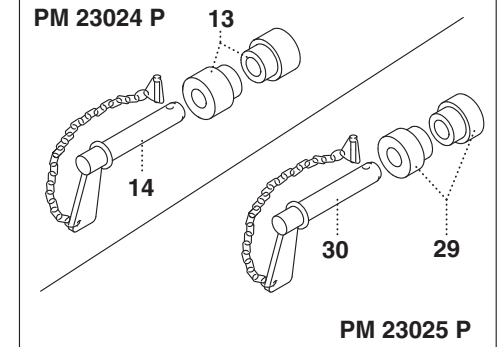
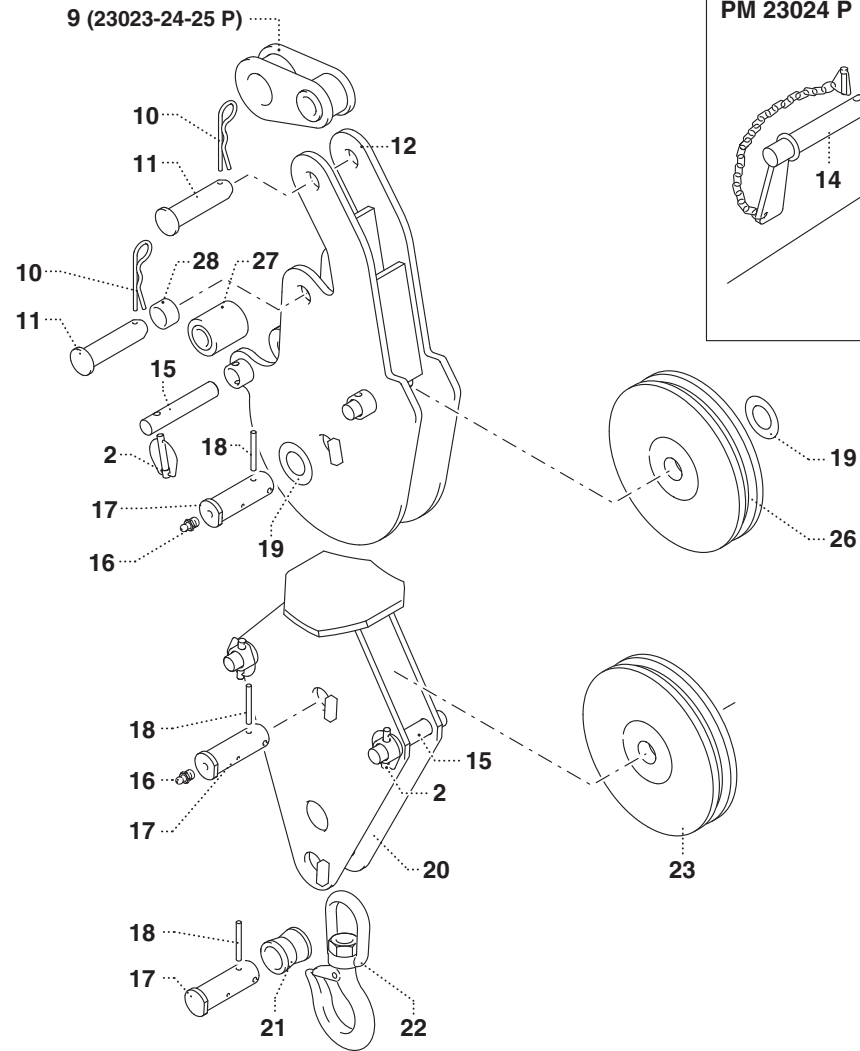
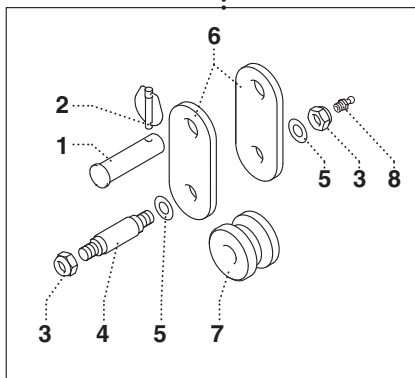
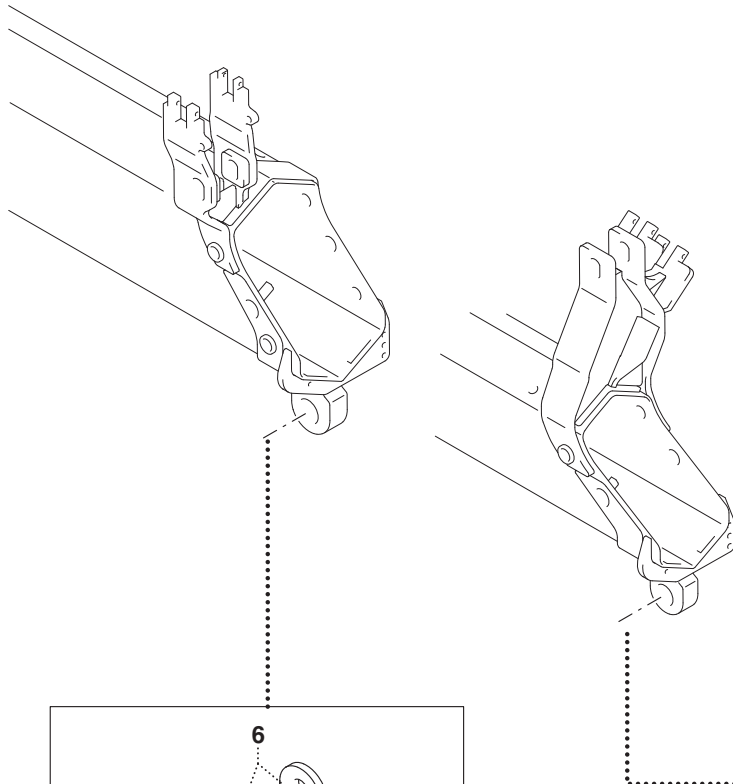

PM 23 P

matr. G107.0005

TAV. SV.10.01

POS.	N° CODICE	Q.	DESCRIZIONE	DESIGNATION	BENENNUNG	DESCRIPTION	DENOMINACIONES
1	380272	1	PERNO	AXE	BOLZEN	PIN	PERNO
2	177079	5	COPIGLIA	GOUPILLE	SPLINT	SPLIT PIN	PASADOR
3	191089	2	DADO	ECROU	MUTTER	NUT	TUERCA
4	380238	1	PERNO	AXE	BOLZEN	PIN	PERNO
5	417008	2	RONDELLA	RONDELLE	SCHEIBE	WASHER	ARANDELA
6	209069	2	FIANCATA	COTE	SEITENWAND	SIDE PANEL	LADO
7	405026	1	PULEGGIA	POULIE	SCHEIBE	PULLEY	POLEA
8	281004	1	INGRASSATORE	GRAISSEUR	SCHMIERER	GREASE FITTING	ENGRASADOR
9	220518	1	FORCELLA	FOURCHE	GABEL	CLEVIS	HORQUILLA
10	451003	2	COPIGLIA	GOUPILLE	SPLINT	SPLIT PIN	PASADOR
11	379585	2	PERNO	AXE	BOLZEN	PIN	PERNO
12	467612	1	SUPPORTO	SUPPORT	TRÄGER	SUPPORT	SOPORTE
13	136966	2	DISTANZIALE	ENTRETOISE	DISTANZSTÜCK	SPACER	DISTANCIADOR
14	379324	1	PERNO	AXE	BOLZEN	PIN	PERNO
15	380192	4	PERNO	AXE	BOLZEN	PIN	PERNO
16	281010	2	INGRASSATORE	GRAISSEUR	SCHMIERER	GREASE FITTING	ENGRASADOR
17	380254	3	PERNO	AXE	BOLZEN	PIN	PERNO
18	455007	3	SPILLA	EPINGLE	SPLINT	SAFETY-PIN	PERNO DE SEGURIDAD
19	417175	2	RONDELLA	RONDELLE	SCHEIBE	WASHER	ARANDELA
20	466575	1	SUPPORTO	SUPPORT	TRÄGER	SUPPORT	SOPORTE
21	136588	1	BOCCOLA	DOUILLE	BUCHSE	BUSHING	CASQUILLO
22	235061	1	GANCIO	CROCHET	HAKEN	HOOK	GANCHO
23	405030	1	PULEGGIA	POULIE	SCHEIBE	PULLEY	POLEA
24	136967	2	BOCCOLA	DOUILLE	BUCHSE	BUSHING	CASQUILLO
25	379348	1	PERNO	AXE	BOLZEN	PIN	PERNO
26	405029	1	PULEGGIA	POULIE	SCHEIBE	PULLEY	POLEA



BOZZELLO TC1 (2 TIRI) (23 P)

- * Poulie TC1 (2 tractions)
- * TC1 Seilblock (2 Züge)
- * TC1 line block (2 pulls)
- * Poleas TC1 (2 tiros)

TAV. SV.10.01

matr. G107.0005

21
23 P

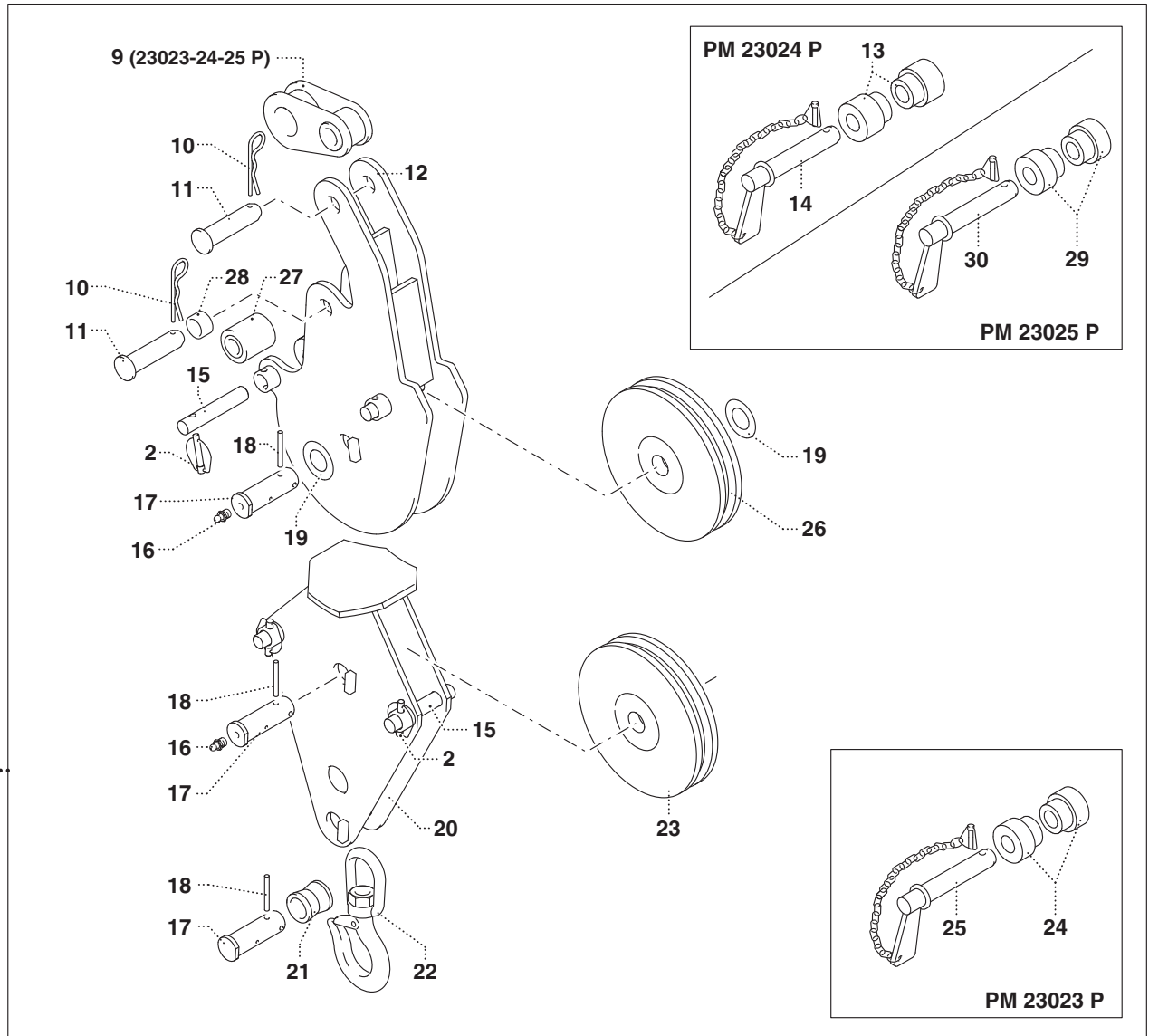
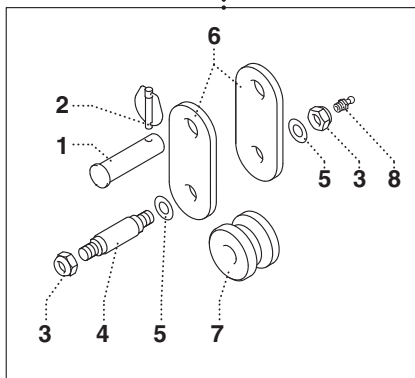
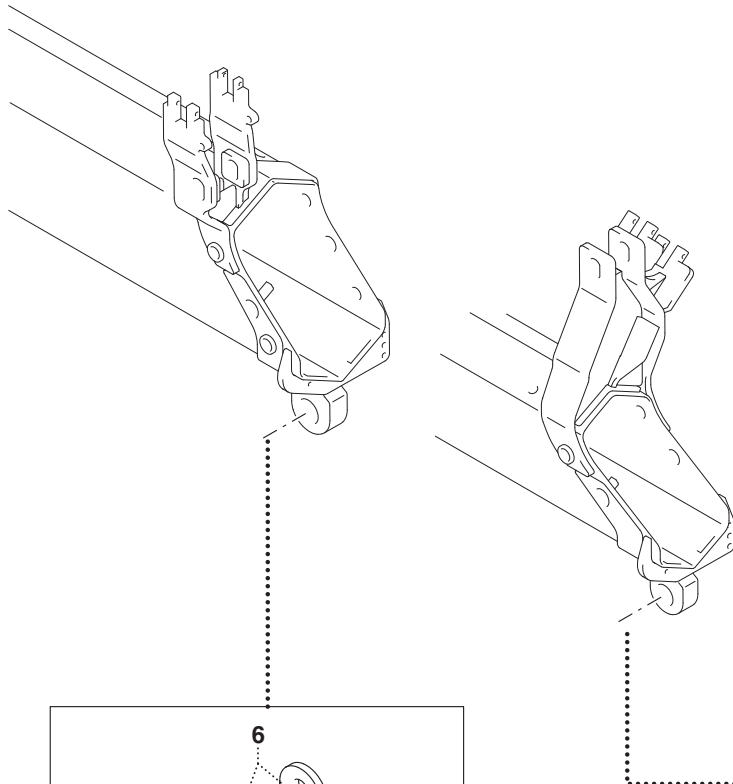



BOZZELLO TC2 (1 TIRO) (23 P)

- * Poulie TC2 (1 traction)
- * TC2 Seilblock (1 Zug)
- * TC2 line block (1 pull)
- * Poleas TC2 (1 tiro)

TAV. SV.11.01

matr. G107.0005

21
23 P

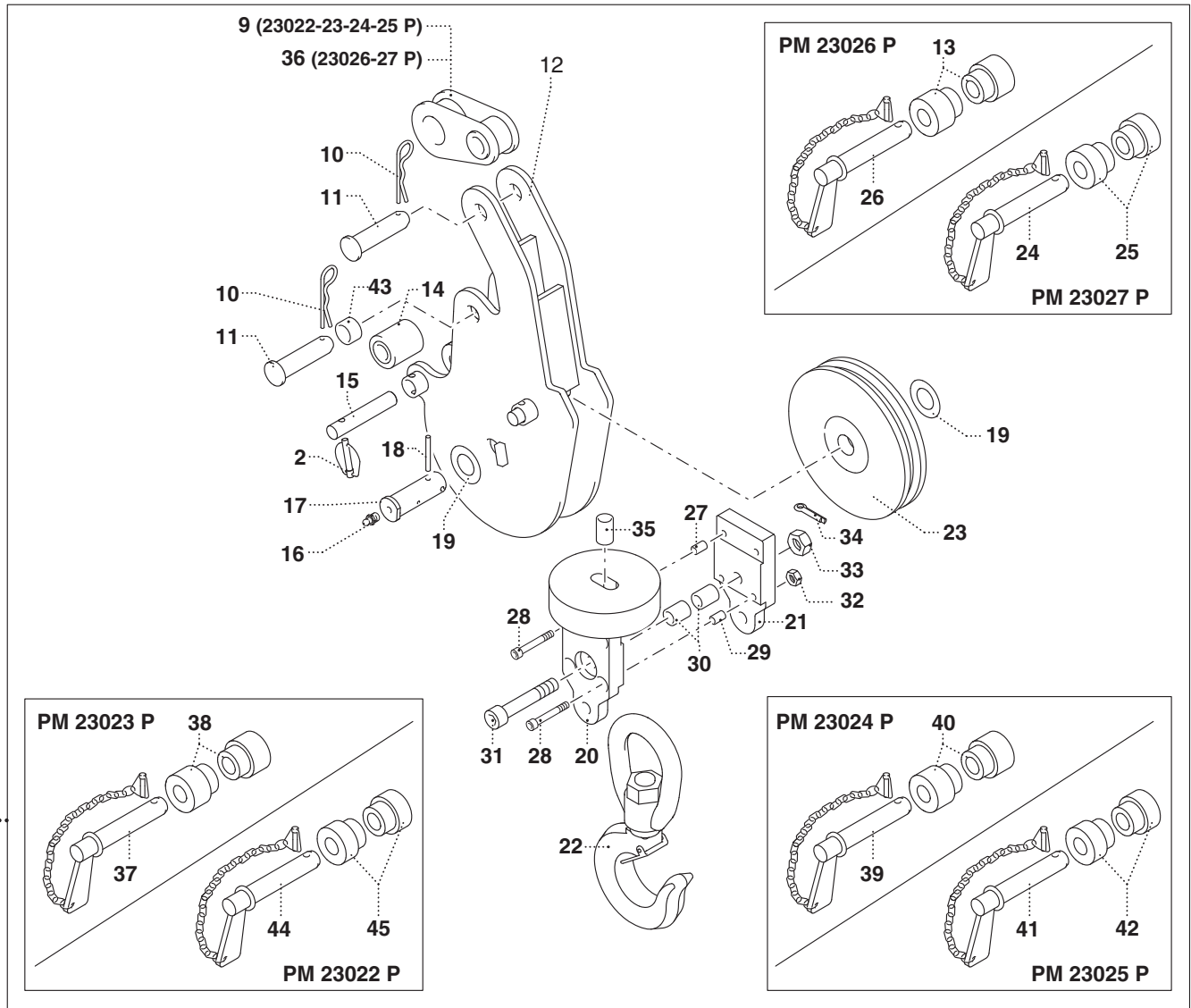
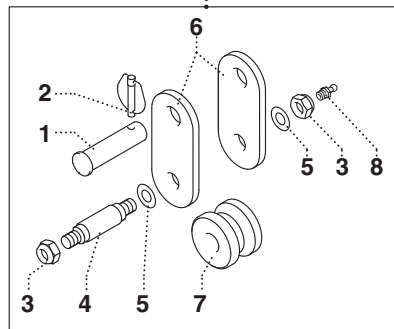
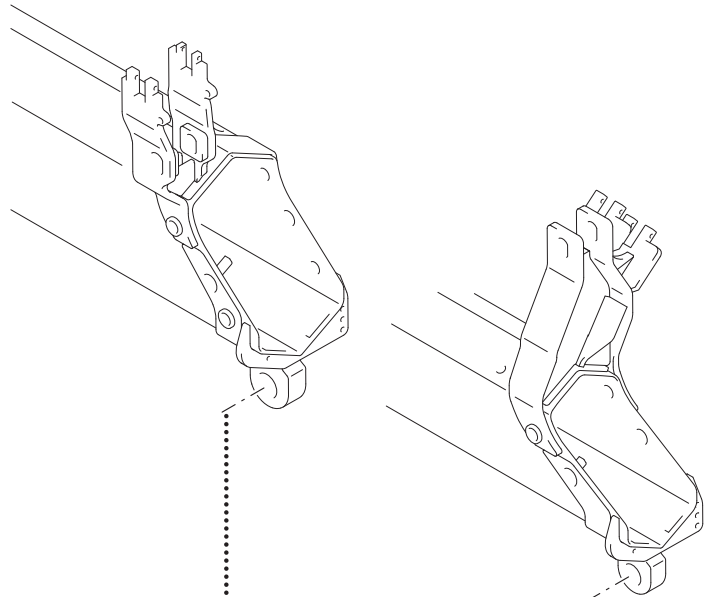

PM 23 P

matr. G107.0005

TAV. SV.11.01

POS.	N° CODICE	Q.	DESCRIZIONE	DESIGNATION	BENENNUNG	DESCRIPTION	DENOMINACIONES
1	380272	1	PERNO	AXE	BOLZEN	PIN	PERNO
2	177079	3	COPIGLIA	GOUPILLE	SPLINT	SPLIT PIN	PASADOR
3	191089	2	DADO	ECROU	MUTTER	NUT	TUERCA
4	380238	1	PERNO	AXE	BOLZEN	PIN	PERNO
5	417008	2	RONDELLA	RONDELLE	SCHEIBE	WASHER	ARANDELA
6	209069	2	FIANCATA	COTE	SEITENWAND	SIDE PANEL	LADO
7	405026	1	PULEGGIA	POULIE	SCHEIBE	PULLEY	POLEA
8	281004	1	INGRASSATORE	GRAISSEUR	SCHMIERER	GREASE FITTING	ENGRASADOR
9	220518	1	FORCELLA	FOURCHE	GABEL	CLEVIS	HORQUILLA
10	451003	2	COPIGLIA	GOUPILLE	SPLINT	SPLIT PIN	PASADOR
11	379585	2	PERNO	AXE	BOLZEN	PIN	PERNO
12	467612	1	SUPPORTO	SUPPORT	TRÄGER	SUPPORT	SOPORTE
13	136589	2	DISTANZIALE	ENTRETOISE	DISTANZSTÜCK	SPACER	DISTANCIADOR
14	429065	1	RULLO	GALET	ROLLE	ROLLER	RODILLO
15	380192	2	PERNO	AXE	BOLZEN	PIN	PERNO
16	281010	1	INGRASSATORE	GRAISSEUR	SCHMIERER	GREASE FITTING	ENGRASADOR
17	380254	1	PERNO	AXE	BOLZEN	PIN	PERNO
18	455007	1	SPILLA	EPINGLE	SPLINT	SAFETY-PIN	PERNO DE SEGURIDAD
19	417175	2	RONDELLA	RONDELLE	SCHEIBE	WASHER	ARANDELA
20	467268	1	SUPPORTO	SUPPORT	TRÄGER	SUPPORT	SOPORTE
21	209072	1	FIANCATA	COTE	SEITENWAND	SIDE PANEL	LADO
22	235029	1	GANCIO	CROCHET	HAKEN	HOOK	GANCHO
23	405029	1	PULEGGIA	POULIE	SCHEIBE	PULLEY	POLEA
24	379203	1	PERNO	AXE	BOLZEN	PIN	PERNO
25	139034	2	DISTANZIALE	ENTRETOISE	DISTANZSTÜCK	SPACER	DISTANCIADOR
26	379202	1	PERNO	AXE	BOLZEN	PIN	PERNO



BOZZELLO TC2 (1 TIRO) (23 P)

- * Poulie TC2 (1 traction)
- * TC2 Seilblock (1 Zug)
- * TC2 line block (1 pull)
- * Poleas TC2 (1 tiro)

TAV. SV.11.01

matr. G107.0005

21
23 P

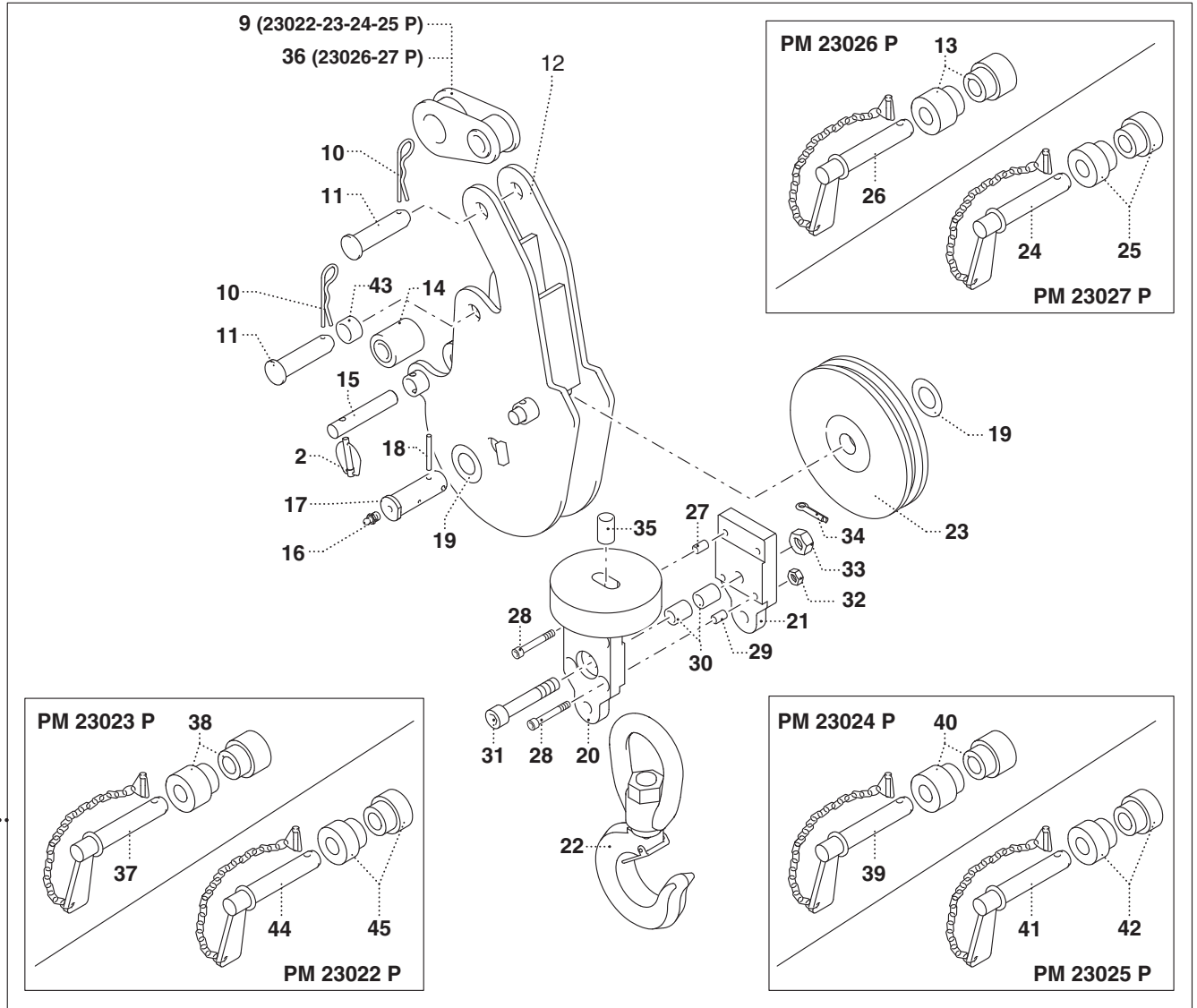
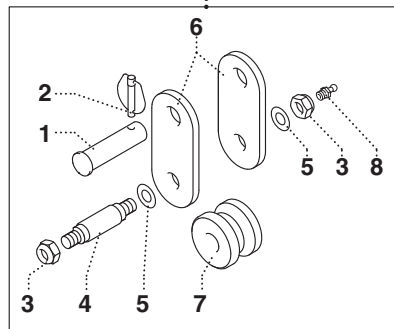
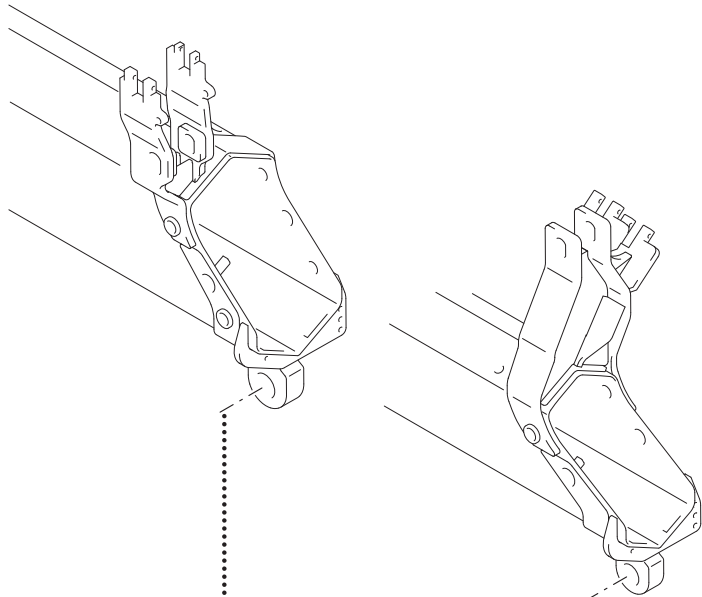

PM 23 P

matr. G107.0005

TAV. SV.11.01

POS.	N° CODICE	Q.	DESCRIZIONE	DESIGNATION	BENENNUNG	DESCRIPTION	DENOMINACIONES
27	136334	2	BOCCOLA	DOUILLE	BUCHSE	BUSHING	CASQUILLO
28	497171	4	VITE	VIS	SCHRAUBE	SCREW	TORNILLO
29	136250	2	BOCCOLA	DOUILLE	BUCHSE	BUSHING	CASQUILLO
30	136871	2	BOCCOLA	DOUILLE	BUCHSE	BUSHING	CASQUILLO
31	497470	1	VITE	VIS	SCHRAUBE	SCREW	TORNILLO
32	191095	4	DADO	ECROU	MUTTER	NUT	TUERCA
33	191012	1	DADO	ECROU	MUTTER	NUT	TUERCA
34	451001	1	COPIGLIA	GOUPILLE	SPLINT	SPLIT PIN	PASADOR
35	488048	1	TUBO RIGIDO	TUYAU RIGIDE	ROHR	PIPE	TUBO RIGIDO
36	220517	1	FORCELLA	FOURCHE	GABEL	CLEVIS	HORQUILLA
37	379348	1	PERNO	AXE	BOLZEN	PIN	PERNO
38	136967	2	BOCCOLA	DOUILLE	BUCHSE	BUSHING	CASQUILLO
39	379324	1	PERNO	AXE	BOLZEN	PIN	PERNO
40	136966	2	BOCCOLA	DOUILLE	BUCHSE	BUSHING	CASQUILLO
41	379325	1	PERNO	AXE	BOLZEN	PIN	PERNO
42	136965	2	BOCCOLA	DOUILLE	BUCHSE	BUSHING	CASQUILLO
43	136964	1	BOCCOLA	DOUILLE	BUCHSE	BUSHING	CASQUILLO
44	379581	1	PERNO	AXE	BOLZEN	PIN	PERNO
45	139035	2	BOCCOLA	DOUILLE	BUCHSE	BUSHING	CASQUILLO



DISPOSITIVO BLOCCO - LIMITATORE ROTAZIONE

- * Dispositif blocage - limiteur rotation
- * Sperreinrichtung - Rotationsbegrenzer
- * Rotation limiting - stopping device
- * Dispositivo bloqueo limitador rotación

TAV. SW.01.01

matr. G107.0005

21
23 P

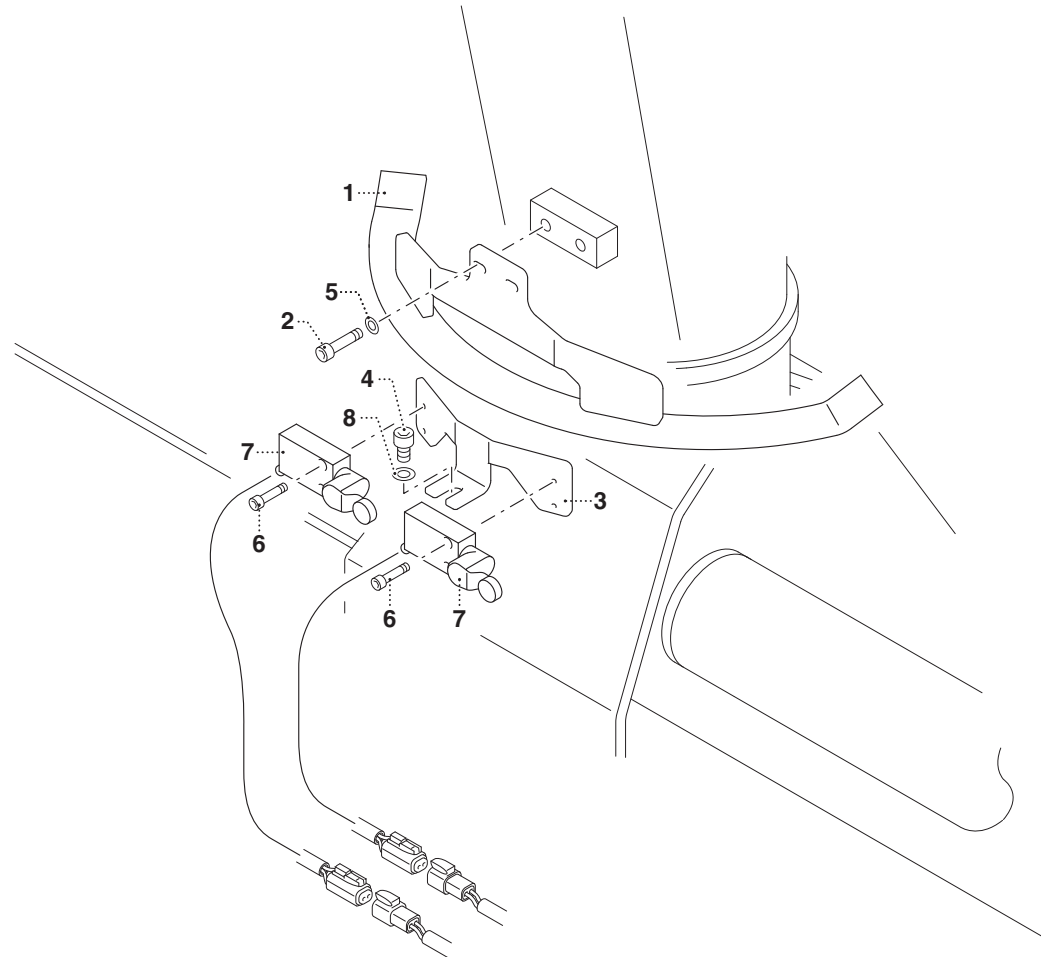

PM 21 - PM 23 P

matr. G107.0005

TAV. SW.01.01

POS.	N° CODICE	Q.	DESCRIZIONE	DESIGNATION	BENENNUNG	DESCRIPTION	DENOMINACIONES
1	467118	1	SUPPORTO	SUPPORT	TRÄGER	SUPPORT	SOPORTE
2	467119	2	VITE	VIS	SCHRAUBE	SCREW	TORNILLO
3	467509	1	SUPPORTO	SUPPORT	TRÄGER	SUPPORT	SOPORTE
4	467237	1	VITE	VIS	SCHRAUBE	SCREW	TORNILLO
5	417024	2	RONDELLA	RONDELLE	SCHEIBE	WASHER	ARANDELA
6	497835	4	VITE	VIS	SCHRAUBE	SCREW	TORNILLO
7	395734	2	MICROINTERRUTTORE	MICRO-INTERRUPTEUR	MIKROSCHALTER	MICRO-SWITCH	MICROINTERRUPTOR
8	417004	1	RONDELLA	RONDELLE	SCHEIBE	WASHER	ARANDELA

PM 21

matr. G107.0005

TAV. SW.02.01 1/2

POS.	N° CODICE	Q.	DESCRIZIONE	DESIGNATION	BENENNUNG	DESCRIPTION	DENOMINACIONES
1	497120	2	VITE	VIS	SCHRAUBE	SCREW	TORNILLO
2	353095	2	MORSETTO	ETAU	KLEMME	CLAMP	PRENSOR
3	191125	4	DADO	ECROU	MUTTER	NUT	TUERCA
4	176450	1	CARTER	CARTER	GEHÄUSE	CASING	CARTER
5	191178	4	DADO	ECROU	MUTTER	NUT	TUERCA
6	497271	4	VITE	VIS	SCHRAUBE	SCREW	TORNILLO
7	349136	4	FERMO	ARRET	VERSTELLVORRICHTUNG	LOCK	TOPE
8	497238	4	VITE	VIS	SCHRAUBE	SCREW	TORNILLO
9	176449	1	CARTER	CARTER	GEHÄUSE	CASING	CARTER
10	497905	1	VITE	VIS	SCHRAUBE	SCREW	TORNILLO
11	497118	1	VITE	VIS	SCHRAUBE	SCREW	TORNILLO
12	417148	4	RONDELLA	RONDELLE	SCHEIBE	WASHER	ARANDELA
13	191155	4	DADO	ECROU	MUTTER	NUT	TUERCA
14	395474	2	MICROINTERRUPTORE	MICRO-INTERRUPTEUR	MIKROSCHALTER	MICRO-SWITCH	MICROINTERRUPTOR
15	262181	1	PROTEZIONE	PROTECTION	SCHUTZ	GUARD	PROTECCION
16	417024	10	RONDELLA	RONDELLE	SCHEIBE	WASHER	ARANDELA
17	497123	4	VITE	VIS	SCHRAUBE	SCREW	TORNILLO
18	200415	1	MICROINTERRUPTORE	MICRO-INTERRUPTEUR	MIKROSCHALTER	MICRO-SWITCH	MICROINTERRUPTOR
19	176325	1	CARTER	CARTER	GEHÄUSE	CASING	CARTER
20	176324	1	CARTER	CARTER	GEHÄUSE	CASING	CARTER
21	191017	4	DADO	ECROU	MUTTER	NUT	TUERCA
22	497111	4	VITE	VIS	SCHRAUBE	SCREW	TORNILLO
23		1	SCATOLA	BOITE	GEHÄUSE	BOX	CAJA
24	466675	1	SUPPORTO	SUPPORT	TRÄGER	SUPPORT	SOPORTE
25	497108	4	VITE	VIS	SCHRAUBE	SCREW	TORNILLO
26	191168	4	DADO	ECROU	MUTTER	NUT	TUERCA



DISPOSITIVI DI SICUREZZA - BHP (21)

- * Dispositifs de sécurité - BHP
- * Sicherungsvorrichtungen - BHP
- * Safety devices - BHP
- * Dispositivos de seguridad - BHP

TAV. SW.02.01 2/2

matr. G107.0005

21
23 P

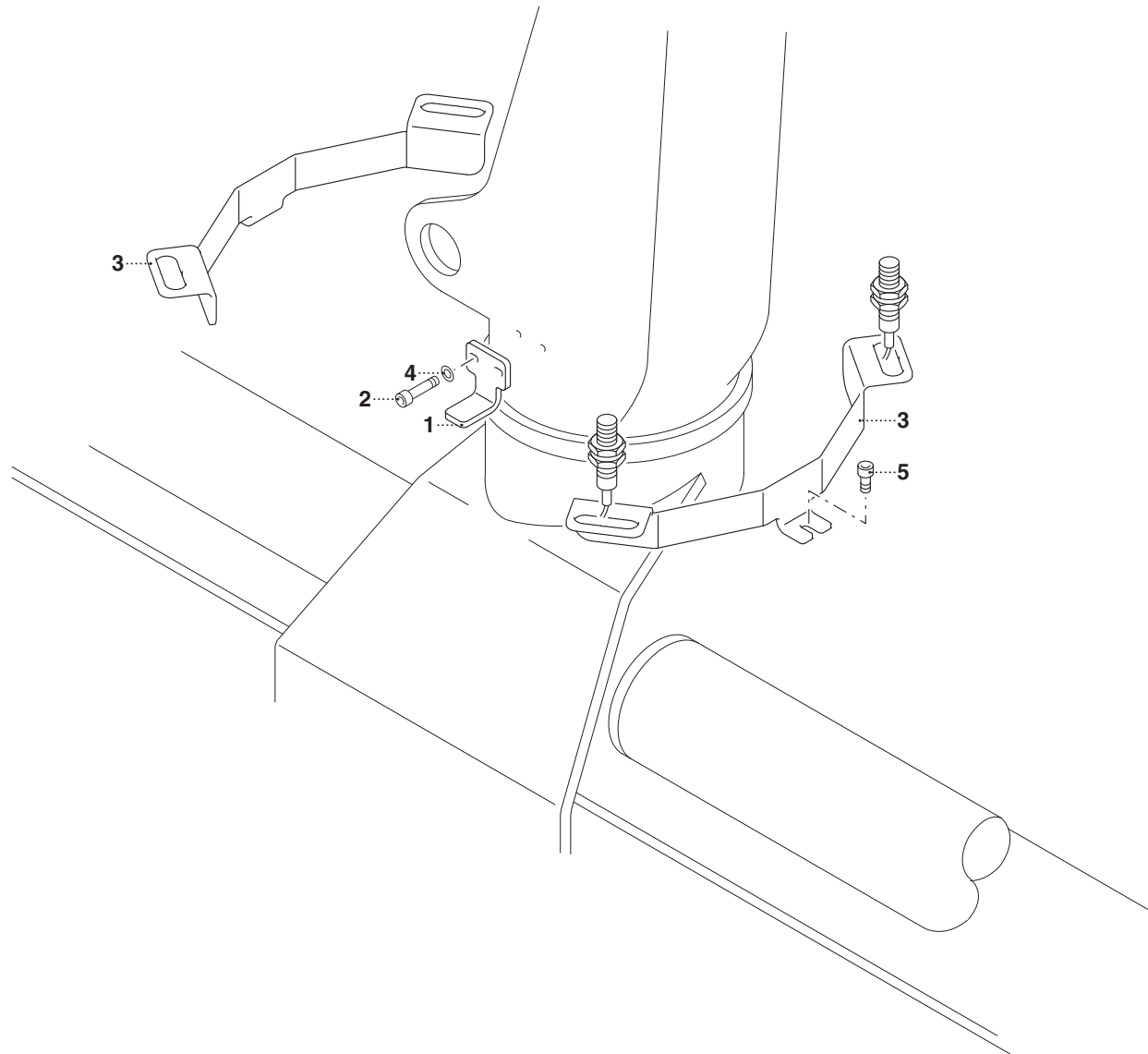



SICUREZZA APPOGGIO STABILIZZATORI (INTERLOCK)

- * Sécurité appui stabilisateurs (INTERLOCK)
- * Stützeunterlege Sicherung (INTERLOCK)
- * Outriggers bearing security (INTERLOCK)
- * Seguridad pie estabilizadores (INTERLOCK)

TAV. SW.20.01

matr. G107.0005

21
23 P

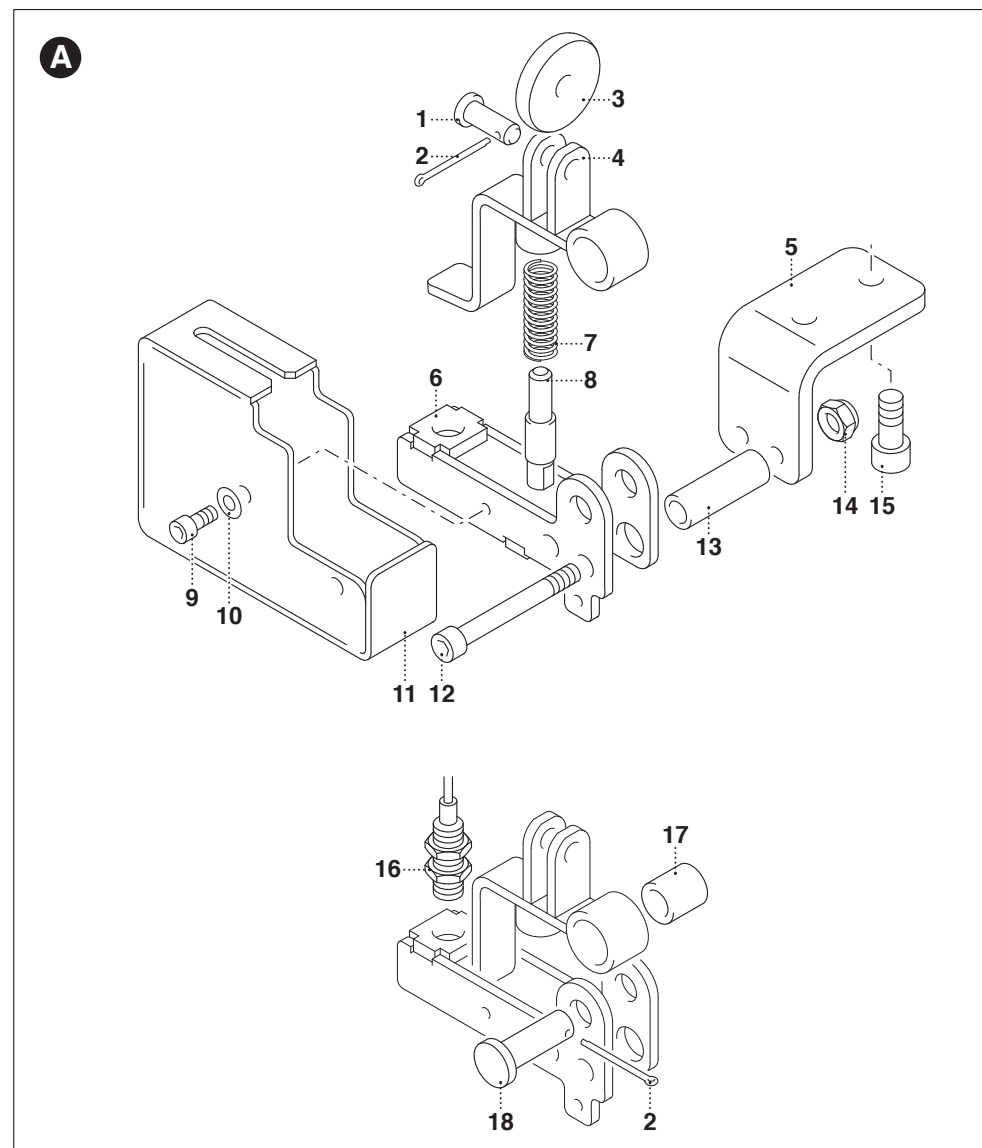
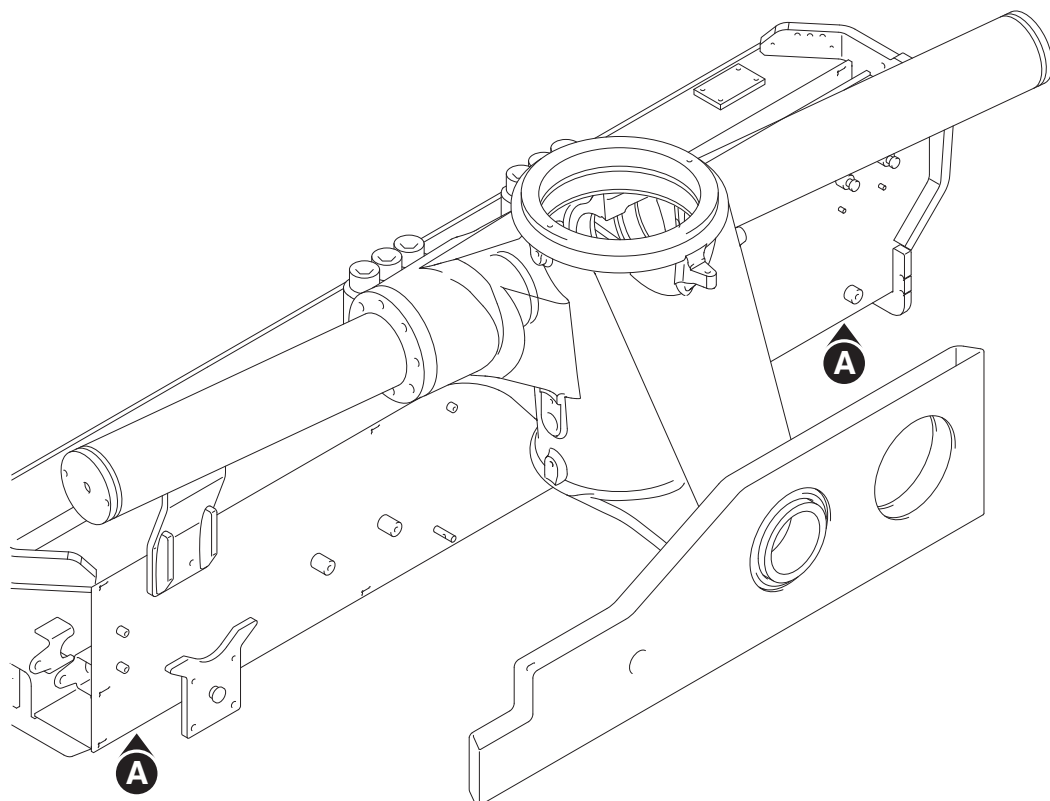

PM 21 - PM 23 P

matr. G107.0005

TAV. SW.20.01

POS.	N° CODICE	Q.	DESCRIZIONE	DESIGNATION	BENENNUNG	DESCRIPTION	DENOMINACIONES
1	380539	2	PERNO	AXE	BOLZEN	PIN	PERNO
2	177002	4	COPIGLIA	GOUPILLE	SPLINT	SPLIT PIN	PASADOR
3	429080	2	RULLO	GALET	ROLLE	ROLLER	RODILLO
4	467746	2	SUPPORTO	SUPPORT	TRÄGER	SUPPORT	SOPORTE
5	467765	4	SUPPORTO	SUPPORT	TRÄGER	SUPPORT	SOPORTE
6	467745	2	SUPPORTO	SUPPORT	TRÄGER	SUPPORT	SOPORTE
7	349092	2	MOLLA	RESSORT	FEDER	SPRING	MUELLE
8	380551	2	PERNO	AXE	BOLZEN	PIN	PERNO
9	497588	4	VITE	VIS	SCHRAUBE	SCREW	TORNILLO
10	717001	4	RONDELLA	RONDELLE	SCHEIBE	WASHER	ARANDELA
11	176454	2	CARTER	CARTER	GEHÄUSE	CASING	CARTER
12	497125	4	VITE	VIS	SCHRAUBE	SCREW	TORNILLO
13	139088	4	BOCCOLA	DOUILLE	BUCHSE	BUSHING	CASQUILLO
14	191125	4	DADO	ECROU	MUTTER	NUT	TUERCA
15	497118	4	VITE	VIS	SCHRAUBE	SCREW	TORNILLO
16	395829	2	SENSORE	CAPTEUR	SENSOR	SENSOR	SENSOR
17	139087	2	BOCCOLA	DOUILLE	BUCHSE	BUSHING	CASQUILLO
18	380550	2	PERNO	AXE	BOLZEN	PIN	PERNO



DISPOSITIVO BLOCCO - LIMITATORE ROTAZIONE - INTERLOCK 3 (23 P)

- * Dispositif blocage - limiteur rotation - INTERLOCK 3
- * Sperreinrichtung - Rotationsbegrenzer - INTERLOCK 3
- * Rotation limiting - stopping device - INTERLOCK 3
- * Dispositivo bloqueo limitador rotación - INTERLOCK 3

TAV. SW.21.01

matr. G107.0005

21
23 P

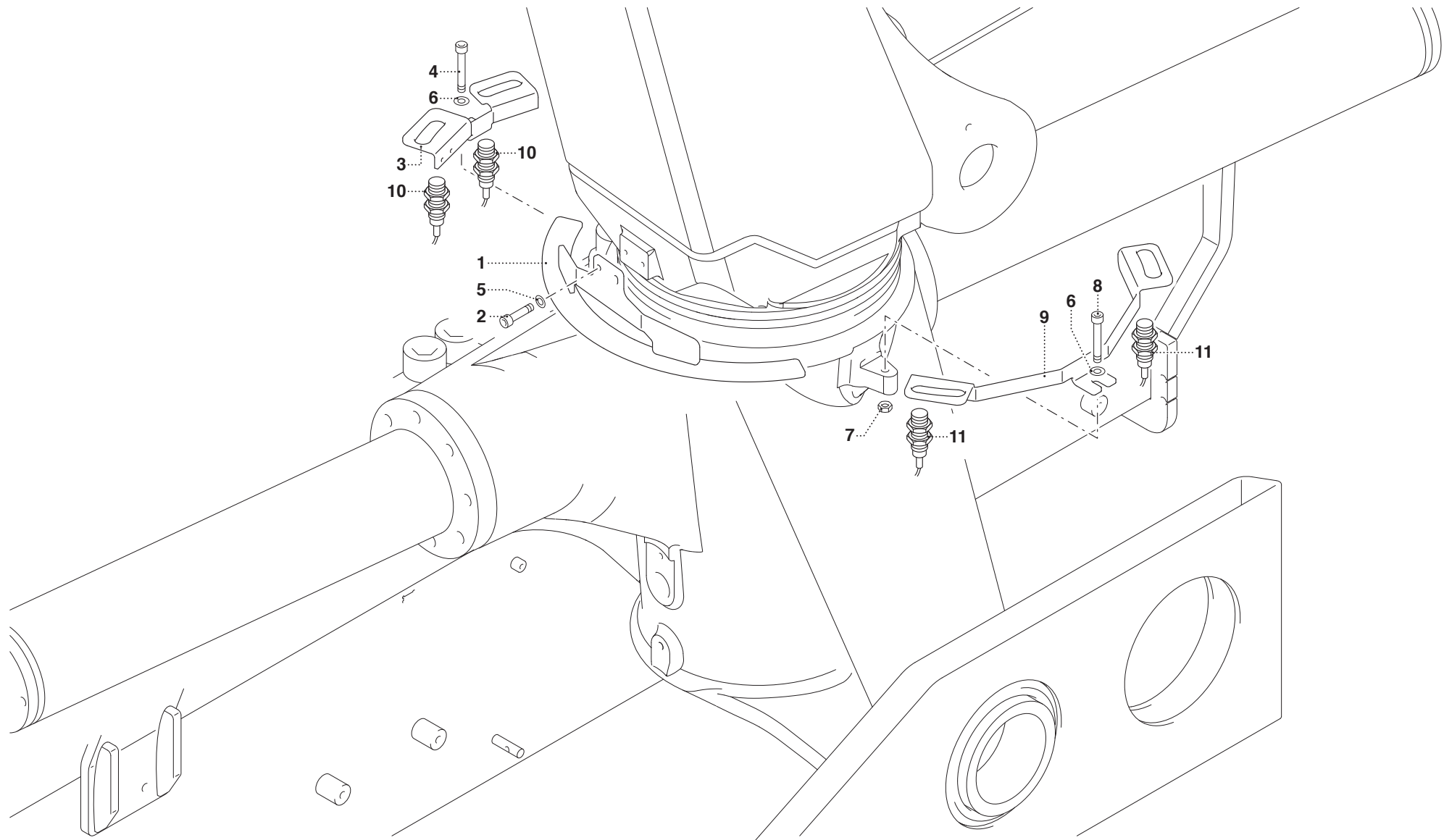

UN01-R-2307-DI

PM 23 P**matr. G107.0005****TAV. SW.21.01**

POS.	N° CODICE	Q.	DESCRIZIONE	DESIGNATION	BENENNUNG	DESCRIPTION	DENOMINACIONES
1	467695	1	SUPPORTO	SUPPORT	TRÄGER	SUPPORT	SOPORTE
2	497119	2	VITE	VIS	SCHRAUBE	SCREW	TORNILLO
3	467693	1	SUPPORTO	SUPPORT	TRÄGER	SUPPORT	SOPORTE
4	497132	1	VITE	VIS	SCHRAUBE	SCREW	TORNILLO
5	417024	2	RONDELLA	RONDELLE	SCHEIBE	WASHER	ARANDELA
6	417004	2	RONDELLA	RONDELLE	SCHEIBE	WASHER	ARANDELA
7	191063	1	DADO	ECROU	MUTTER	NUT	TUERCA
8	497138	1	VITE	VIS	SCHRAUBE	SCREW	TORNILLO
9	467694	1	SUPPORTO	SUPPORT	TRÄGER	SUPPORT	SOPORTE
10	278084	2	SENSORE	CAPTEUR	SENSOR	SENSOR	SENSOR
11	278083	2	SENSORE	CAPTEUR	SENSOR	SENSOR	SENSOR



DISPOSITIVO BLOCCO - LIMITATORE ROTAZIONE - INTERLOCK 5

- * Dispositif blocage - limiteur rotation - INTERLOCK 5
- * Sperreinrichtung - Rotationsbegrenzer - INTERLOCK 5
- * Rotation limiting - stopping device - INTERLOCK 5
- * Dispositivo bloqueo limitador rotación - INTERLOCK 5

TAV. SW.21.02

matr. G107.0005

21
23 P

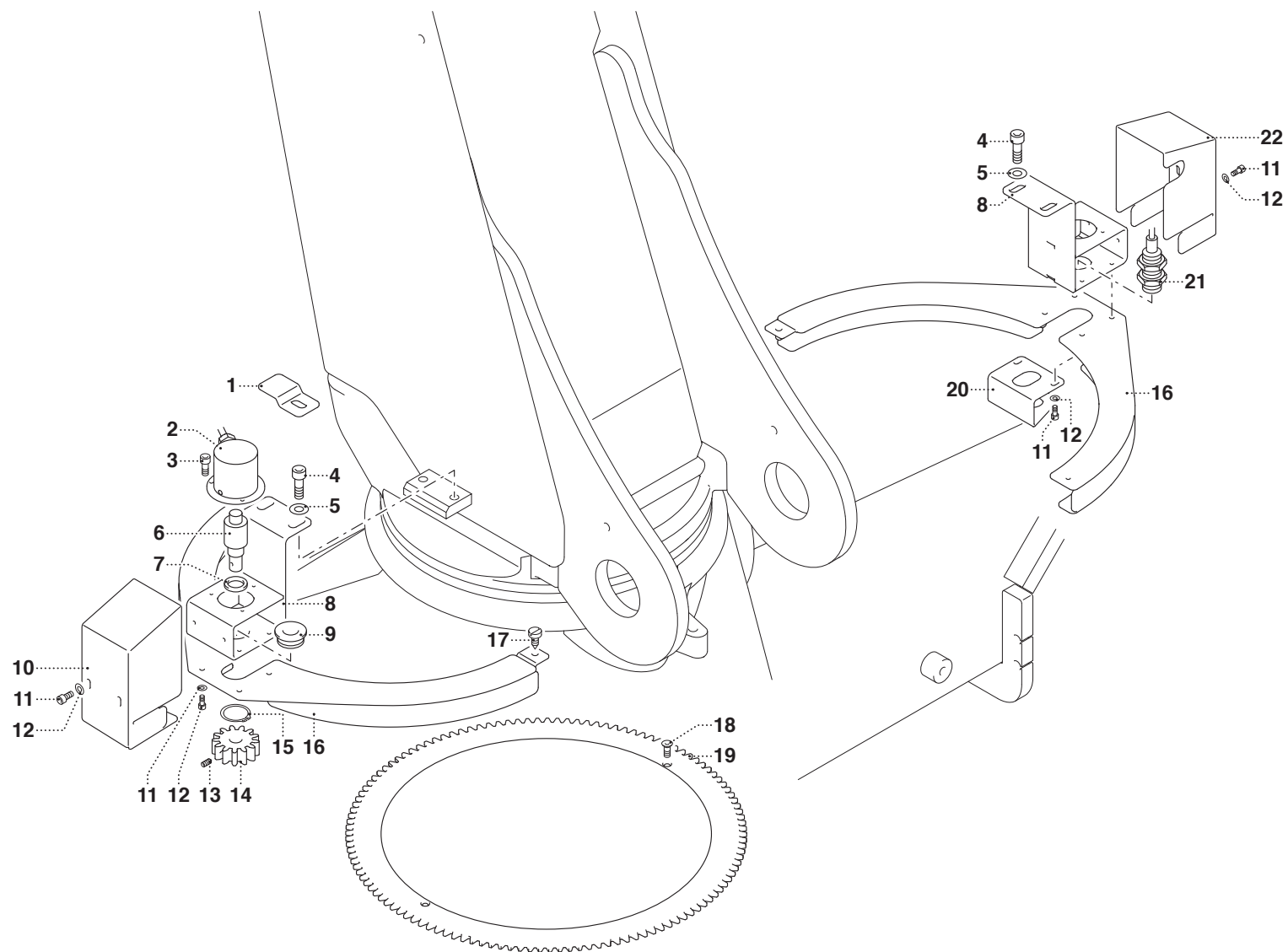

PM 21 - PM 23 P**matr. G107.0005****TAV. SW.21.02**

POS.	N° CODICE	Q.	DESCRIZIONE	DESIGNATION	BENENNUNG	DESCRIPTION	DENOMINACIONES
1	467792	1	SUPPORTO	SUPPORT	TRÄGER	SUPPORT	SOPORTE
2	394039	1	ENCODER	ENCODER	ENCODER	ENCODER	ENCODER
3	497271	3	VITE	VIS	SCHRAUBE	SCREW	TORNILLO
4	497132	4	VITE	VIS	SCHRAUBE	SCREW	TORNILLO
5	417004	4	RONDELLA	RONDELLE	SCHEIBE	WASHER	ARANDELA
6	380574	1	PERNO	AXE	BOLZEN	PIN	PERNO
7	112257	1	ANELLO	BAGUE	RING	RING	ANILLO
8	467788	2	SUPPORTO	SUPPORT	TRÄGER	SUPPORT	SOPORTE
9	139070	1	BOCCOLA	DOUILLE	BUCHSE	BUSHING	CASQUILLO
10	176471	1	CARTER	CARTER	GEHÄUSE	CASING	CARTER
11	497588	12	VITE	VIS	SCHRAUBE	SCREW	TORNILLO
12	417001	12	RONDELLA	RONDELLE	SCHEIBE	WASHER	ARANDELA
13	497276	1	VITE	VIS	SCHRAUBE	SCREW	TORNILLO
14	431048	1	RUOTA DENTATA	ROUE A PIGNON	ZAHNRAD	GEAR WHEEL	RUEDA DENTADA
15	109210	1	ANELLO ELASTICO	JOINT D'ARRET	SPRENGRING	SPRING RING	ANILLO ELASTICO
16	467789	2	SUPPORTO	SUPPORT	TRÄGER	SUPPORT	SOPORTE
17	497970	2	VITE	VIS	SCHRAUBE	SCREW	TORNILLO
18	497863	2	VITE	VIS	SCHRAUBE	SCREW	TORNILLO
19	324788	1	LAMIERA	TOLE	BLECH	PLATE	LAMINA
20	467791	1	SUPPORTO	SUPPORT	TRÄGER	SUPPORT	SOPORTE
21	395633	1	SENSORE	CAPTEUR	SENSOR	SENSOR	SENSOR
22	176462	1	CARTER	CARTER	GEHÄUSE	CASING	CARTER



COMPL. COMANDO MARTINETTO STABILIZZATORE (BRACCI STANDARD) - INTERLOCK 5

- * Compl. commande vérin stabilisateur (bras standard) - INTERLOCK 5
- * Ergänzung des Steuerungs der Stützylinder (Standardarme) - INTERLOCK 5
- * Outrigger cylinder control compl. (standard arms) - INTERLOCK 5
- * Complet. mando gato estabilizador (brazos estándar) - INTERLOCK 5

TAV. SW.22.01 1/2

matr. G107.0005

21
23 P

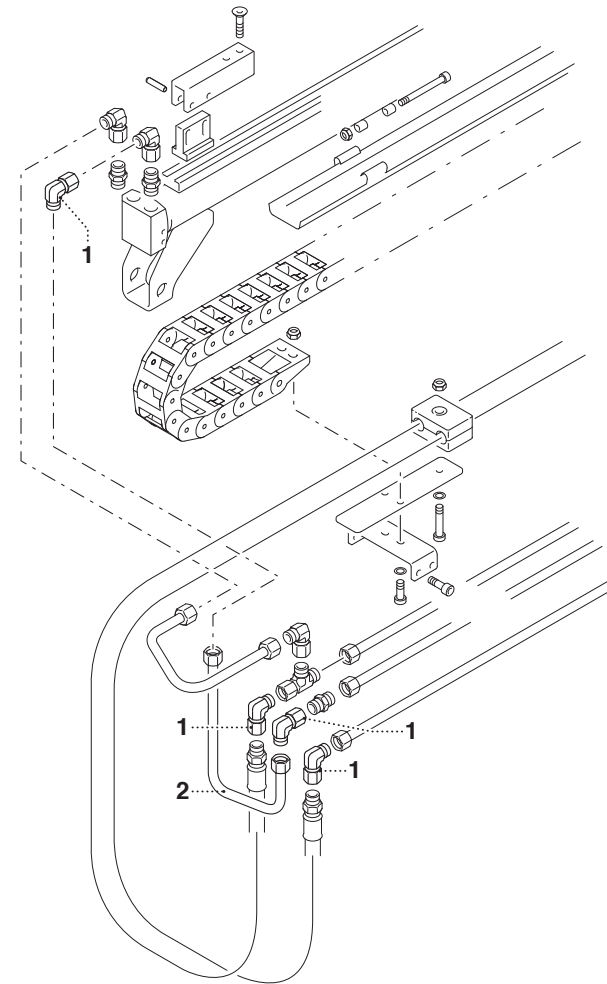
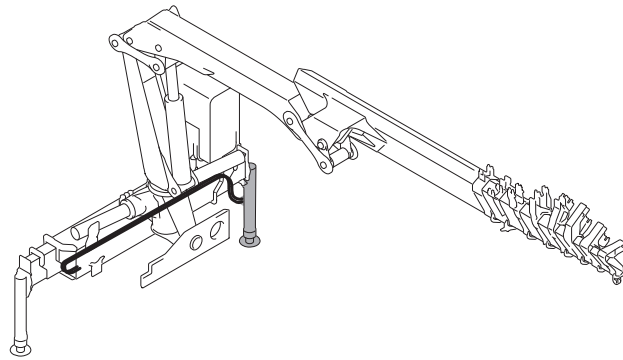



COMPL. COMANDO MARTINETTO STABILIZZATORE (BRACCI STANDARD) - INTERLOCK 5

- * Compl. commande vérin stabilisateur (bras standard) - INTERLOCK 5
- * Ergänzung des Steuerungs der Stützylinder (Standardarme) - INTERLOCK 5
- * Outrigger cylinder control compl. (standard arms) - INTERLOCK 5
- * Complet. mando gato estabilizador (brazos estándar) - INTERLOCK 5

TAV. SW.22.01 2/2

matr. G107.0005

21
23 P

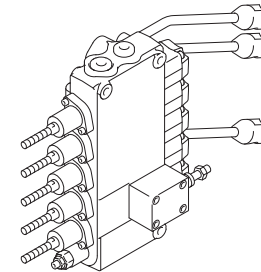
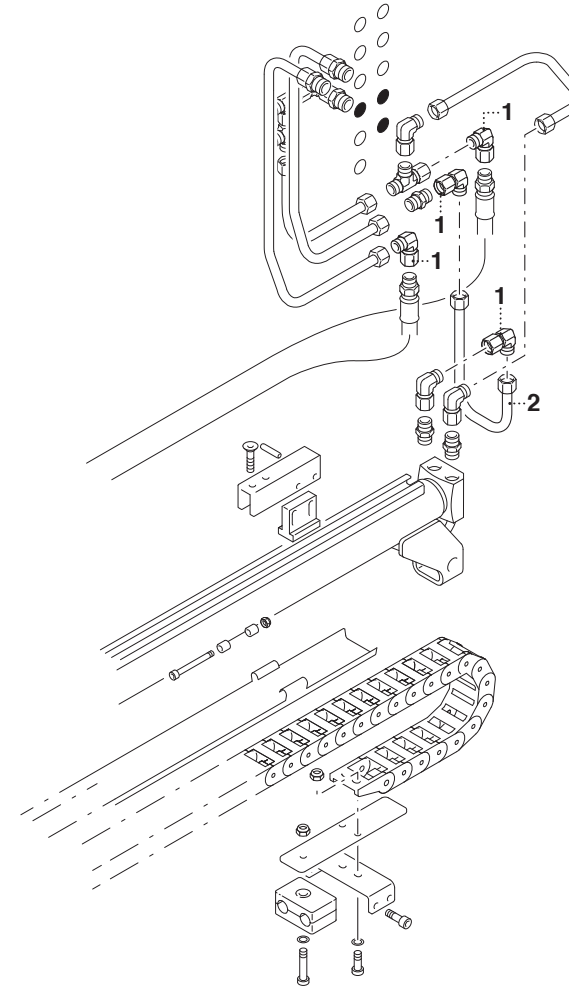
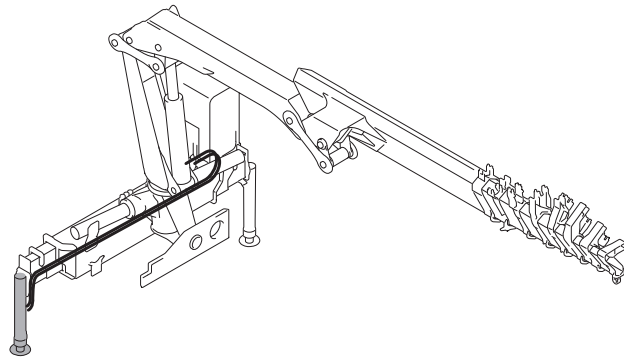



COMPL. INTERLOCK 3-4 - 3° PUNTO DI MANOVRA

- * Compl. INTERLOCK 3-4 - 3ème point de manœuvre
- * INTERLOCK 3-4 Ergänzung - 3. Manöverplatz
- * Compl. INTERLOCK 3-4 - 3rd manoeuvre position
- * Complet. INTERLOCK 3-4 - 3er punto de maniobra

TAV. SW.23.01

matr. G107.0005

21
23 P

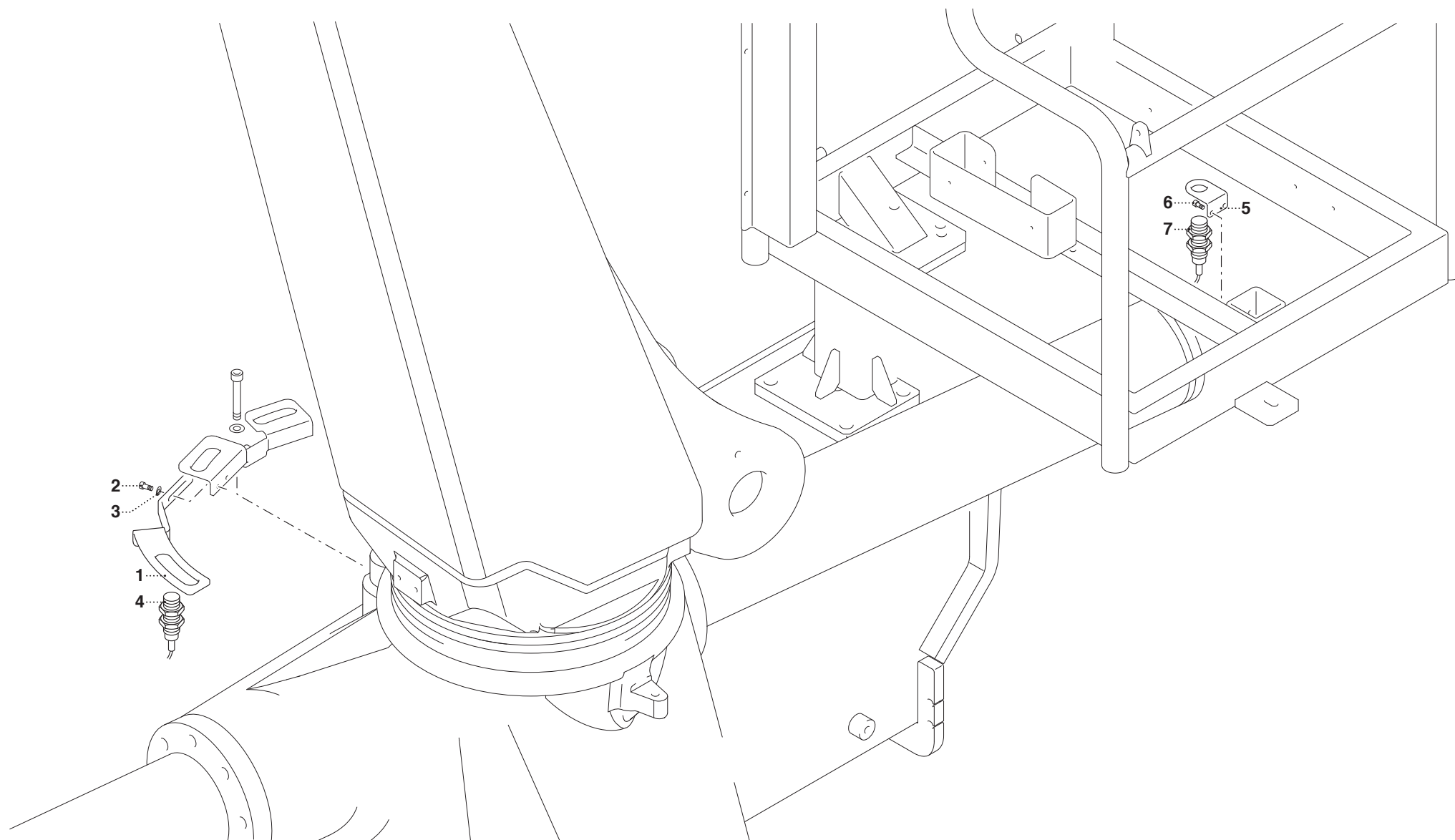

PM 21 - PM 23 P

matr. G107.0005

TAV. SW.23.01

POS.	N° CODICE	Q.	DESCRIZIONE	DESIGNATION	BENENNUNG	DESCRIPTION	DENOMINACIONES
1	467743	1	SUPPORTO	SUPPORT	TRÄGER	SUPPORT	SOPORTE
2	497110	2	VITE	VIS	SCHRAUBE	SCREW	TORNILLO
3	417050	2	RONDELLA	RONDELLE	SCHEIBE	WASHER	ARANDELA
4	395633	1	SENSORE	CAPTEUR	SENSOR	SENSOR	SENSOR
5	467883	1	SUPPORTO	SUPPORT	TRÄGER	SUPPORT	SOPORTE
6	497588	2	VITE	VIS	SCHRAUBE	SCREW	TORNILLO
7	278084	1	SENSORE	CAPTEUR	SENSOR	SENSOR	SENSOR



IMPIANTO ELETTRICO - MACCHINA BASE - HYDROCONTROL (MANUALE) (21)

- * Installation électrique - machine standard - HYDROCONTROL (Manuel)
- * Standardmaschine - Elektrischeanlage - HYDROCONTROL (Manuelle)
- * Standard machine - electric system - HYDROCONTROL (Manual)
- * Instalación eléctrica máquina base - HYDROCONTROL (Manual)

TAV. SX.01.01

matr. G107.0005

21
23 P

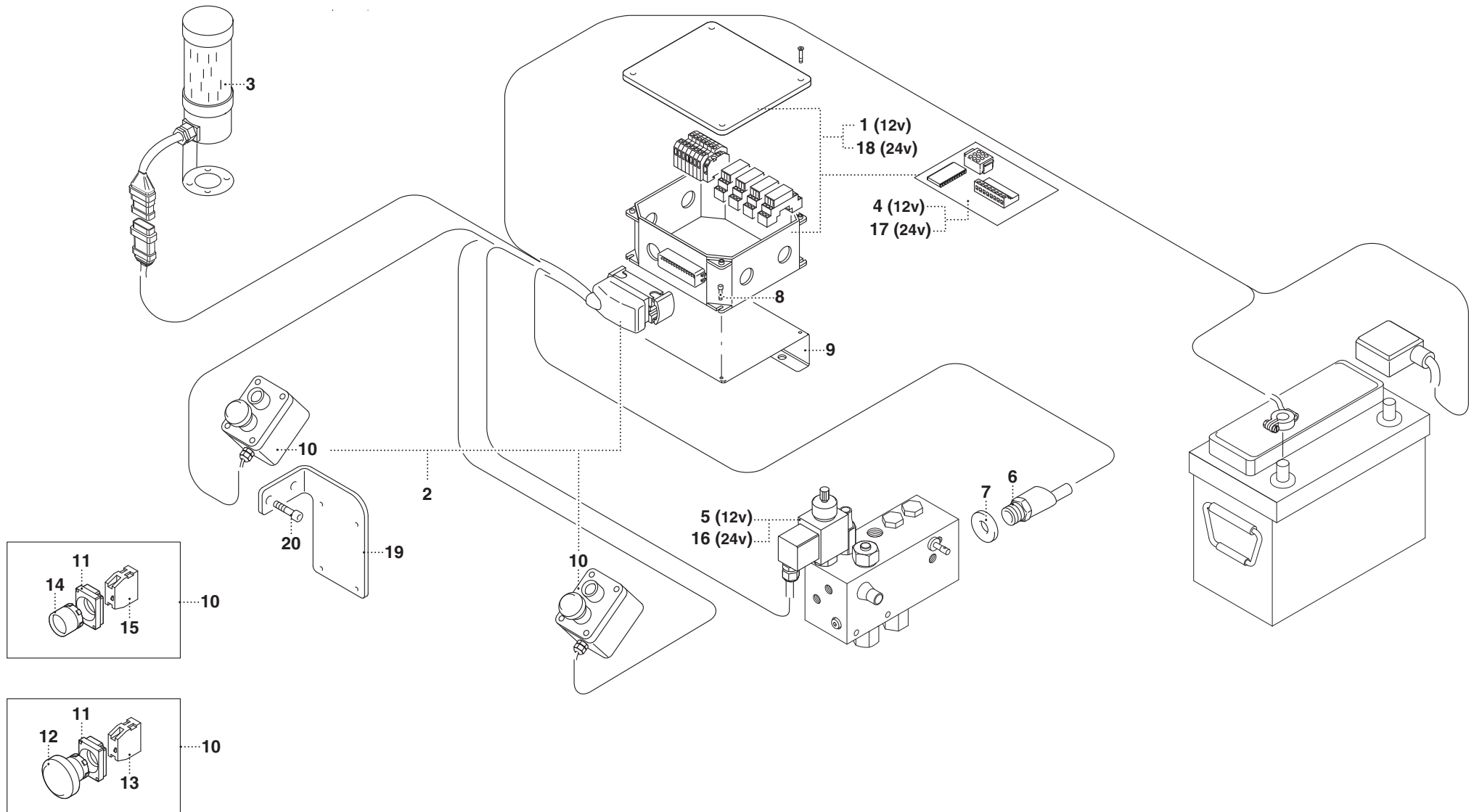

PM 21**matr. G107.0005****TAV. SX.01.01**

POS.	N° CODICE	Q.	DESCRIZIONE	DESIGNATION	BENENNUNG	DESCRIPTION	DENOMINACIONES
1	280729	1	SCATOLA	BOITE	GEHÄUSE	BOX	CAJA
2	280749	1	CABLAGGIO	CABLAGE	VERKABELUNG	SET WIRES	CABLEADO
3	280748	1	KIT LAMPEGGIATORE	KIT CLIGNOTANT	BLINKLICHTSATZ	FLASHLIGHT KIT	KIT INTERMITENTE
4	476063	1	SCHEDA	FICHE	KARTE	BOARD	ESQUELA
5	395379	1	BOBINA	BOBINE	SPULE	COIL	BOBINA
6	395830	1	PRESSOSTATO	PRESSOSTAT	DRUCKMESSER	PRESSURE SWITCH	PRESOSTATO
7	417096	1	RONDELLA	RONDELLE	SCHEIBE	WASHER	ARANDELA
8	497111	4	VITE	VIS	SCHRAUBE	SCREW	TORNILLO
9	467683	1	SUPPORTO	SUPPORT	TRÄGER	SUPPORT	SOPORTE
10	289568	2	KIT SCATOLA	KIT BOITE	GEHÄUSESATZ	BOX KIT	KIT CAJA
11	395599	4	FLANGIA	BRIDE	FLANSCH	FLANGE	BRIDA
12	395628	2	PULSANTE	BOUTON	TASTE	BUTTON	BOTON
13	395601	2	CONTATTO	CONTACT	KONTAKT	CONTACT	CONTACTO
14	395629	2	PULSANTE	BOUTON	TASTE	BUTTON	BOTON
15	395600	2	CONTATTO	CONTACT	KONTAKT	CONTACT	CONTACTO
16	395380	1	BOBINA	BOBINE	SPULE	COIL	BOBINA
17	476064	1	SCHEDA	FICHE	KARTE	BOARD	ESQUELA
18	280780	1	SCATOLA	BOITE	GEHÄUSE	BOX	CAJA
19	467680	1	SUPPORTO	SUPPORT	TRÄGER	SUPPORT	SOPORTE
20	497130	2	VITE	VIS	SCHRAUBE	SCREW	TORNILLO



IMP. ELETTRICO EMERGENZA-MACCHINA BASE - HYDROCONTROL (RADIOCOMANDO) - ARGANO - (21)

* Installation électrique urgence - machine standard - HYDROCONTROL (radiocommande) - treuil
* Not-Aus Vorrichtung Elektrischeanlage - Standardmaschine - HYDROCONTROL (Fernsteuerung) - Winde
* Emergency electric system - Standard machine - HYDROCONTROL (radio control) - winch
* Instalación eléctrica emergencia - máquina base - HYDROCONTROL (radiomando) - cabrestante

TAV. SX.01.02

matr. G107.0005

21
23 P

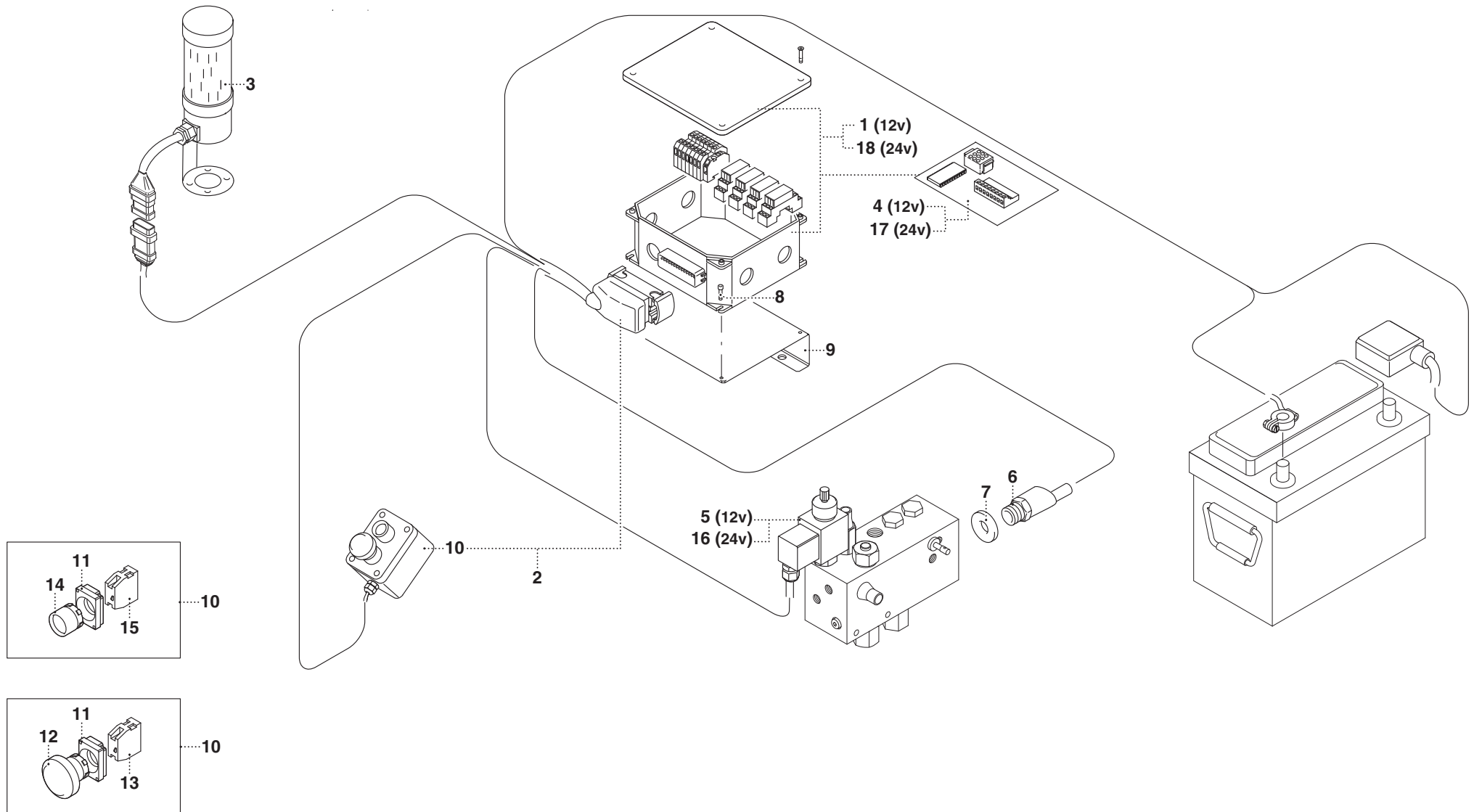

PM 21**matr. G107.0005****TAV. SX.01.02**

POS.	N° CODICE	Q.	DESCRIZIONE	DESIGNATION	BENENNUNG	DESCRIPTION	DENOMINACIONES
1	280729	1	SCATOLA	BOITE	GEHÄUSE	BOX	CAJA
2	280969	1	CABLAGGIO	CABLAGE	VERKABELUNG	SET WIRES	CABLEADO
3	280748	1	KIT LAMPEGGIATORE	KIT CLIGNOTANT	BLINKLICHTSATZ	FLASHLIGHT KIT	KIT INTERMITENTE
4	476063	1	SCHEDA	FICHE	KARTE	BOARD	ESQUELA
5	395379	1	BOBINA	BOBINE	SPULE	COIL	BOBINA
6	395830	1	PRESSOSTATO	PRESSOSTAT	DRUCKMESSER	PRESSURE SWITCH	PRESOSTATO
7	417096	1	RONDELLA	RONDELLE	SCHEIBE	WASHER	ARANDELA
8	497111	4	VITE	VIS	SCHRAUBE	SCREW	TORNILLO
9	467683	1	SUPPORTO	SUPPORT	TRÄGER	SUPPORT	SOPORTE
10	289568	1	KIT SCATOLA	KIT BOITE	GEHÄUSESATZ	BOX KIT	KIT CAJA
11	395599	2	FLANGIA	BRIDE	FLANSCH	FLANGE	BRIDA
12	395628	1	PULSANTE	BOUTON	TASTE	BUTTON	BOTON
13	395601	1	CONTATTO	CONTACT	KONTAKT	CONTACT	CONTACTO
14	395629	1	PULSANTE	BOUTON	TASTE	BUTTON	BOTON
15	395600	1	CONTATTO	CONTACT	KONTAKT	CONTACT	CONTACTO
16	395380	1	BOBINA	BOBINE	SPULE	COIL	BOBINA
17	476064	1	SCHEDA	FICHE	KARTE	BOARD	ESQUELA
18	280780	1	SCATOLA	BOITE	GEHÄUSE	BOX	CAJA



IMPIANTO ELETTRICO EMERGENZA- MACCHINA BASE - HYDROCONTROL (ARGANO) (MANUALE) (21)

* Installation électrique urgence - machine standard - HYDROCONTROL (treuil) (manuel)
* Not-Aus Vorrichtung Elektrischeanlage - Standardmaschine - HYDROCONTROL (Winde) (Manuelle)
* Emergency electric system - Standard machine - HYDROCONTROL (winch) (manual)
* Instalación eléctrica emergencia - máquina base - HYDROCONTROL (cabrestante) (manual)

TAV. SX.02.01 1/2

matr. G107.0005

21
23 P

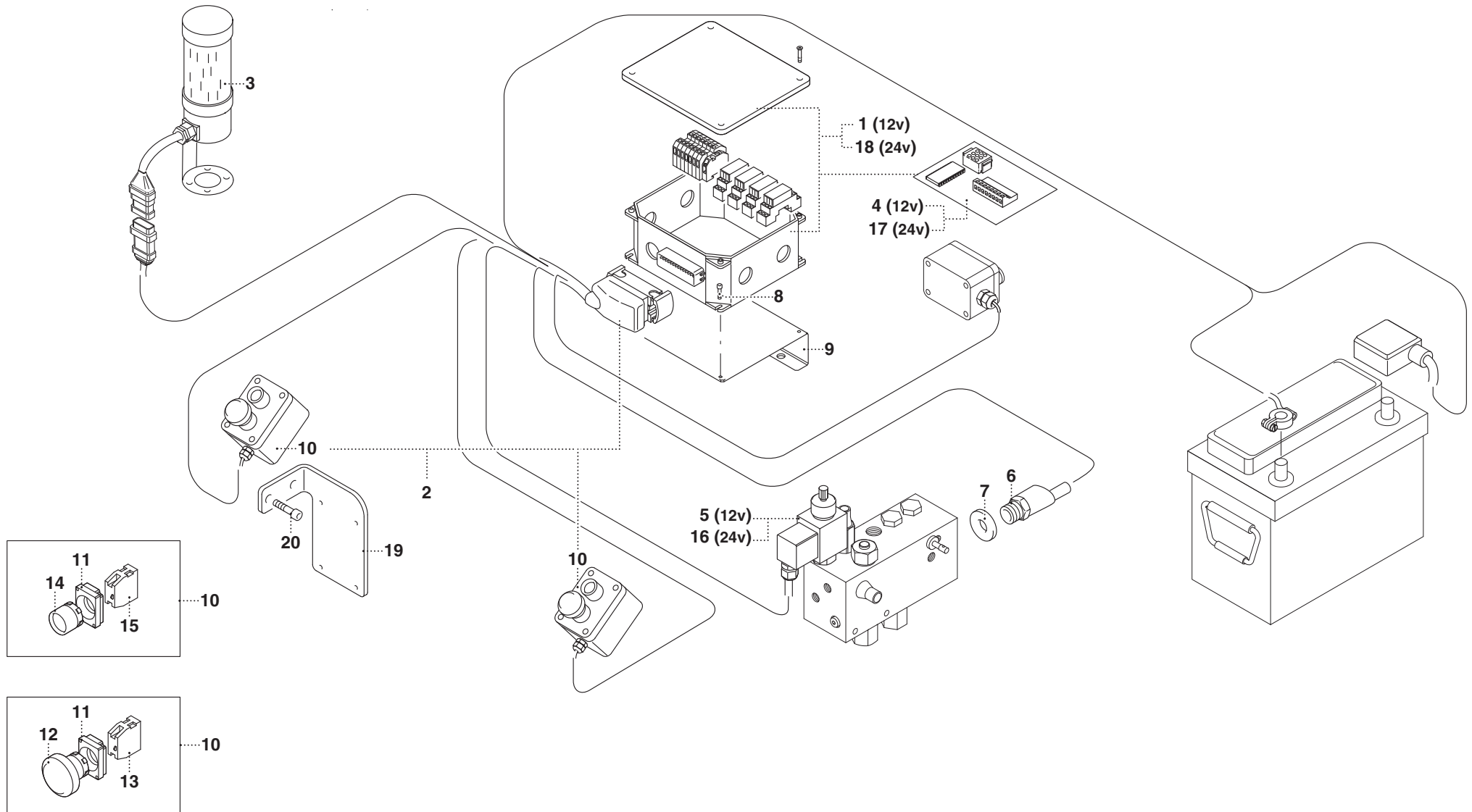

PM 21**matr. G107.0005****TAV. SX.02.01 1/2**

POS.	N° CODICE	Q.	DESCRIZIONE	DESIGNATION	BENENNUNG	DESCRIPTION	DENOMINACIONES
1	280731	1	SCATOLA	BOITE	GEHÄUSE	BOX	CAJA
2	280749	1	CABLAGGIO	CABLAGE	VERKABELUNG	SET WIRES	CABLEADO
3	280748	1	KIT LAMPEGGIATORE	KIT CLIGNOTANT	BLINKLICHTSATZ	FLASHLIGHT KIT	KIT INTERMITENTE
4	476065	1	SCHEDA	FICHE	KARTE	BOARD	ESQUELA
5	395379	1	BOBINA	BOBINE	SPULE	COIL	BOBINA
6	395830	1	PRESSOSTATO	PRESSOSTAT	DRUCKMESSER	PRESSURE SWITCH	PRESOSTATO
7	417096	1	RONDELLA	RONDELLE	SCHEIBE	WASHER	ARANDELA
8	497111	4	VITE	VIS	SCHRAUBE	SCREW	TORNILLO
9	467683	1	SUPPORTO	SUPPORT	TRÄGER	SUPPORT	SOPORTE
10	289568	2	KIT SCATOLA	KIT BOITE	GEHÄUSESATZ	BOX KIT	KIT CAJA
11	395599	4	FLANGIA	BRIDE	FLANSCH	FLANGE	BRIDA
12	395628	2	PULSANTE	BOUTON	TASTE	BUTTON	BOTON
13	395601	2	CONTATTO	CONTACT	KONTAKT	CONTACT	CONTACTO
14	395629	2	PULSANTE	BOUTON	TASTE	BUTTON	BOTON
15	395600	2	CONTATTO	CONTACT	KONTAKT	CONTACT	CONTACTO
16	395380	1	BOBINA	BOBINE	SPULE	COIL	BOBINA
17	476064	1	SCHEDA	FICHE	KARTE	BOARD	ESQUELA
18	280732	1	SCATOLA	BOITE	GEHÄUSE	BOX	CAJA
19	467680	1	SUPPORTO	SUPPORT	TRÄGER	SUPPORT	SOPORTE
20	497130	2	VITE	VIS	SCHRAUBE	SCREW	TORNILLO



IMPIANTO ELETTRICO EMERGENZA- MACCHINA BASE - HYDROCONTROL (ARGANO) (MANUALE) (21)

- * Installation électrique urgence - machine standard - HYDROCONTROL (treuil) (manuel)
- * Not-Aus Vorrichtung Elektrischeanlage - Standardmaschine - HYDROCONTROL (Winde) (Manuelle)
- * Emergency electric system - Standard machine - HYDROCONTROL (winch) (manual)
- * Instalación eléctrica emergencia - máquina base - HYDROCONTROL (cabrestante) (manual)

TAV. SX.02.01 2/2

matr. G107.0005

21
23 P

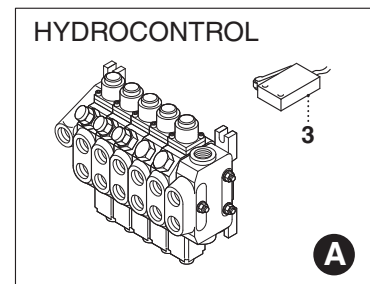
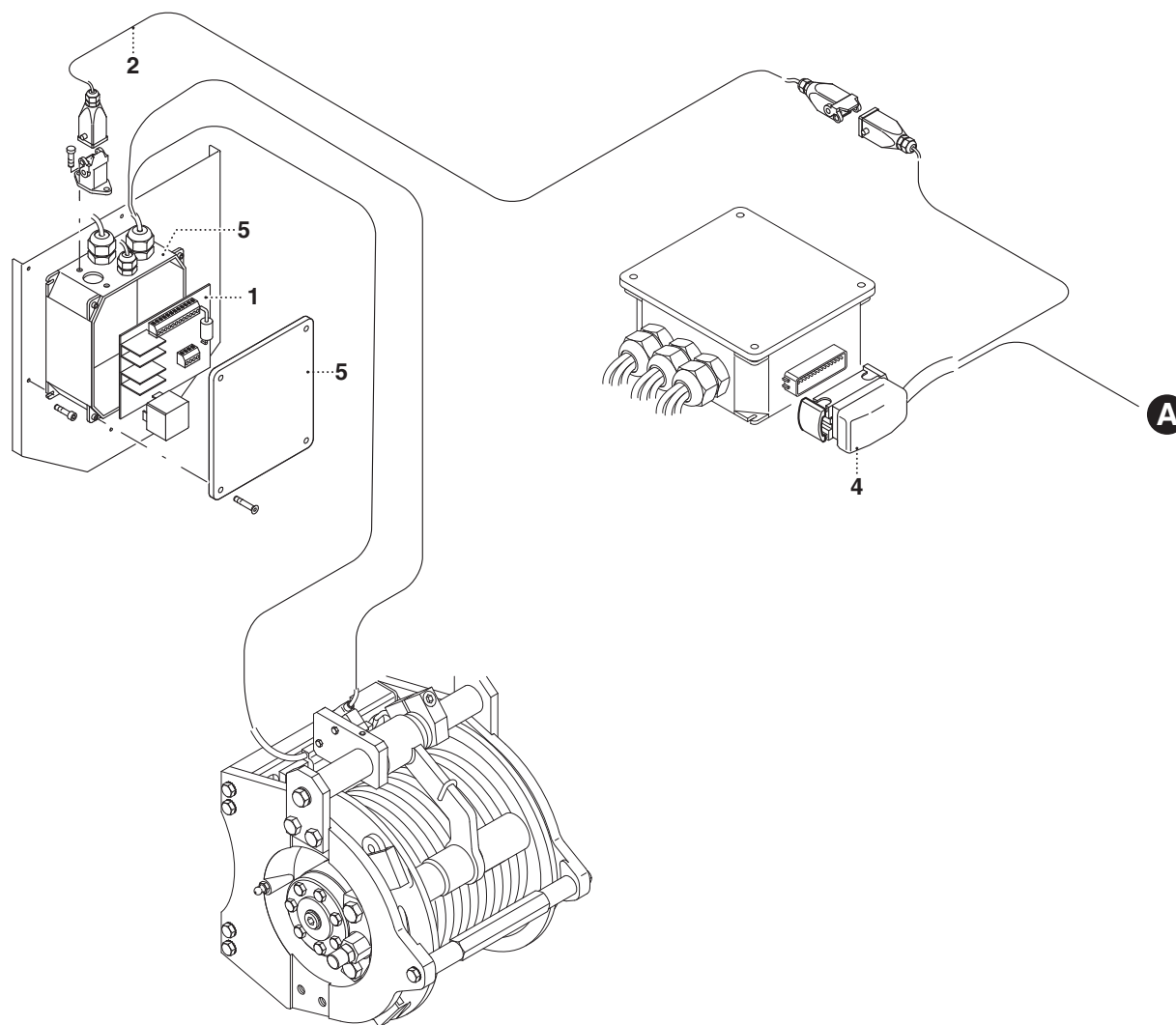

PM 21

matr. G107.0005

TAV. SX.02.01 2/2

POS.	N° CODICE	Q.	DESCRIZIONE	DESIGNATION	BENENNUNG	DESCRIPTION	DENOMINACIONES
1	476031	1	SCHEDA	FICHE	KARTE	BOARD	ESQUELA
2	280546	1	KIT CAVO PROLUNGA	KIT CABLE RALLONGE	VERLÄNGERUNGKABELSATZ	EXTENSION CORD KIT	KIT CABLE PROLONGA
3	200506	1	MICROINTERRUTTORE	MICRO-INTERRUPTEUR	MIKROSCHALTER	MICRO-SWITCH	MICROINTERRUPTOR
4	280742	1	CABLAGGIO	CABLAGE	VERKABELUNG	SET WIRES	CABLEADO
5	280747		SCATOLA	BOITE	GEHÄUSE	BOX	CAJA

PM 21**matr. G107.0005****TAV. SX.02.02 1/2**

POS.	N° CODICE	Q.	DESCRIZIONE	DESIGNATION	BENENNUNG	DESCRIPTION	DENOMINACIONES
1	280731	1	SCATOLA	BOITE	GEHÄUSE	BOX	CAJA
2	280969	1	CABLAGGIO	CABLAGE	VERKABELUNG	SET WIRES	CABLEADO
3	280748	1	KIT LAMPEGGIATORE	KIT CLIGNOTANT	BLINKLICHTSATZ	FLASHLIGHT KIT	KIT INTERMITENTE
4	476065	1	SCHEDA	FICHE	KARTE	BOARD	ESQUELA
5	395379	1	BOBINA	BOBINE	SPULE	COIL	BOBINA
6	395830	1	PRESSOSTATO	PRESSOSTAT	DRUCKMESSER	PRESSURE SWITCH	PRESOSTATO
7	417096	1	RONDELLA	RONDELLE	SCHEIBE	WASHER	ARANDELA
8	497111	4	VITE	VIS	SCHRAUBE	SCREW	TORNILLO
9	467683	1	SUPPORTO	SUPPORT	TRÄGER	SUPPORT	SOPORTE
10	289568	1	KIT SCATOLA	KIT BOITE	GEHÄUSESATZ	BOX KIT	KIT CAJA
11	395599	2	FLANGIA	BRIDE	FLANSCH	FLANGE	BRIDA
12	395628	1	PULSANTE	BOUTON	TASTE	BUTTON	BOTON
13	395601	1	CONTATTO	CONTACT	KONTAKT	CONTACT	CONTACTO
14	395629	1	PULSANTE	BOUTON	TASTE	BUTTON	BOTON
15	395600	1	CONTATTO	CONTACT	KONTAKT	CONTACT	CONTACTO
16	395380	1	BOBINA	BOBINE	SPULE	COIL	BOBINA
17	476066	1	SCHEDA	FICHE	KARTE	BOARD	ESQUELA
18	280732	1	SCATOLA	BOITE	GEHÄUSE	BOX	CAJA



IMPIANTO ELETTRICO EMERGENZA- MACCHINA BASE - HYDROCONTROL (ARGANO) (RADIOCOMANDO) (21)

- * *Installation électrique urgence - machine standard - HYDROCONTROL (treuil) (radiocommande)*
- * *Not-Aus Vorrichtung Elektrischeanlage - Standardmaschine - HYDROCONTROL (Winde) (Fernsteuerung)*
- * *Emergency electric system - Standard machine - HYDROCONTROL (winch) (radio control)*
- * *Instalación eléctrica emergencia - máquina base - HYDROCONTROL (cabrestante) (radiomando)*

TAV. SX.02.02 2/2

matr. G107.0005

21
23 P

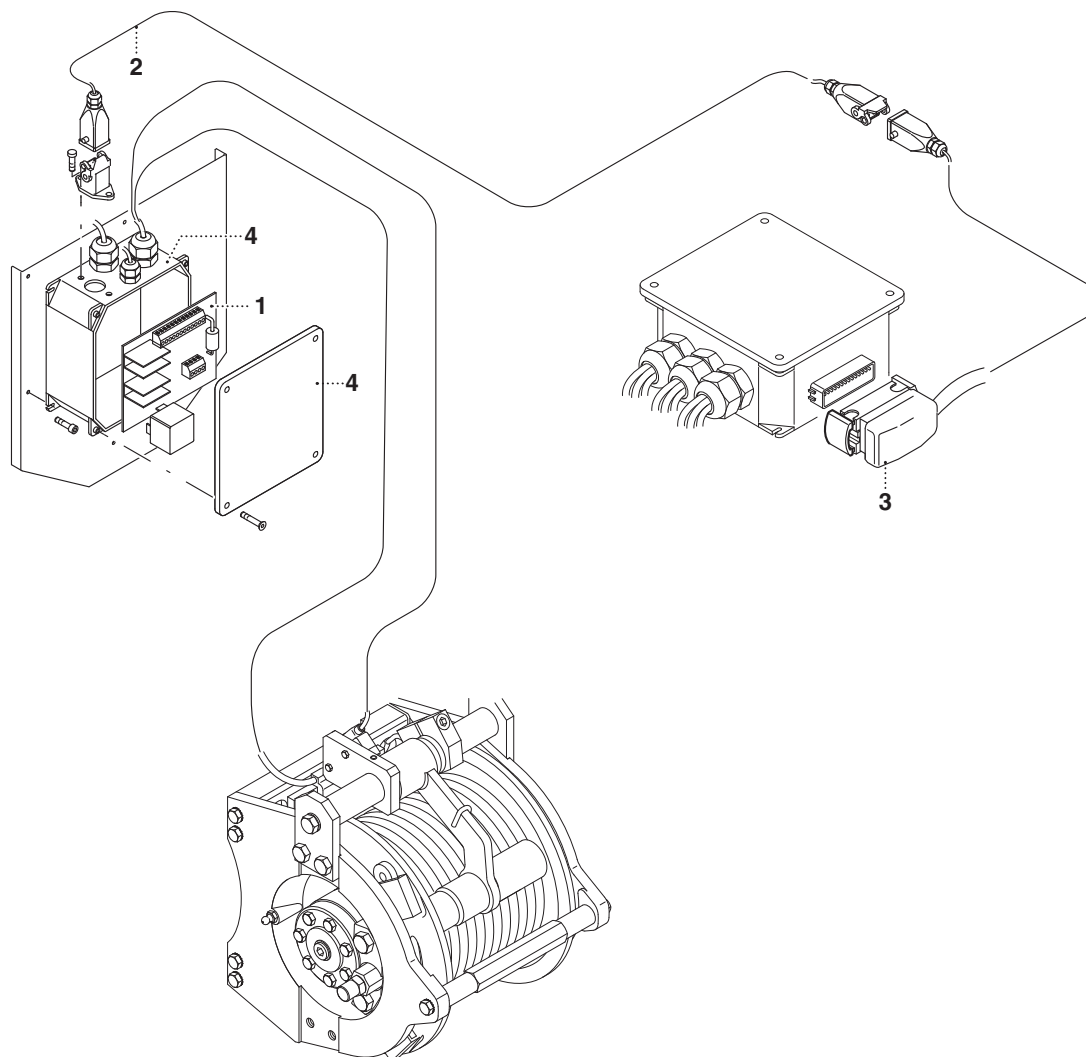



IMPIANTO ELETTRICO EMERGENZA- MACCHINA BASE - DANFOSS (ARGANO) (21)

* Installation électrique urgence - machine standard - DANFOSS (treuil)
* Not-Aus Vorrichtung Elektrischeanlage - Standardmaschine - DANFOSS (Winde)
* Emergency electric system - Standard machine - DANFOSS (winch)
* Instalación eléctrica emergencia - máquina base - DANFOSS (cabrestante)

TAV. SX.02.03 1/2

matr. G107.0005

21
23 P

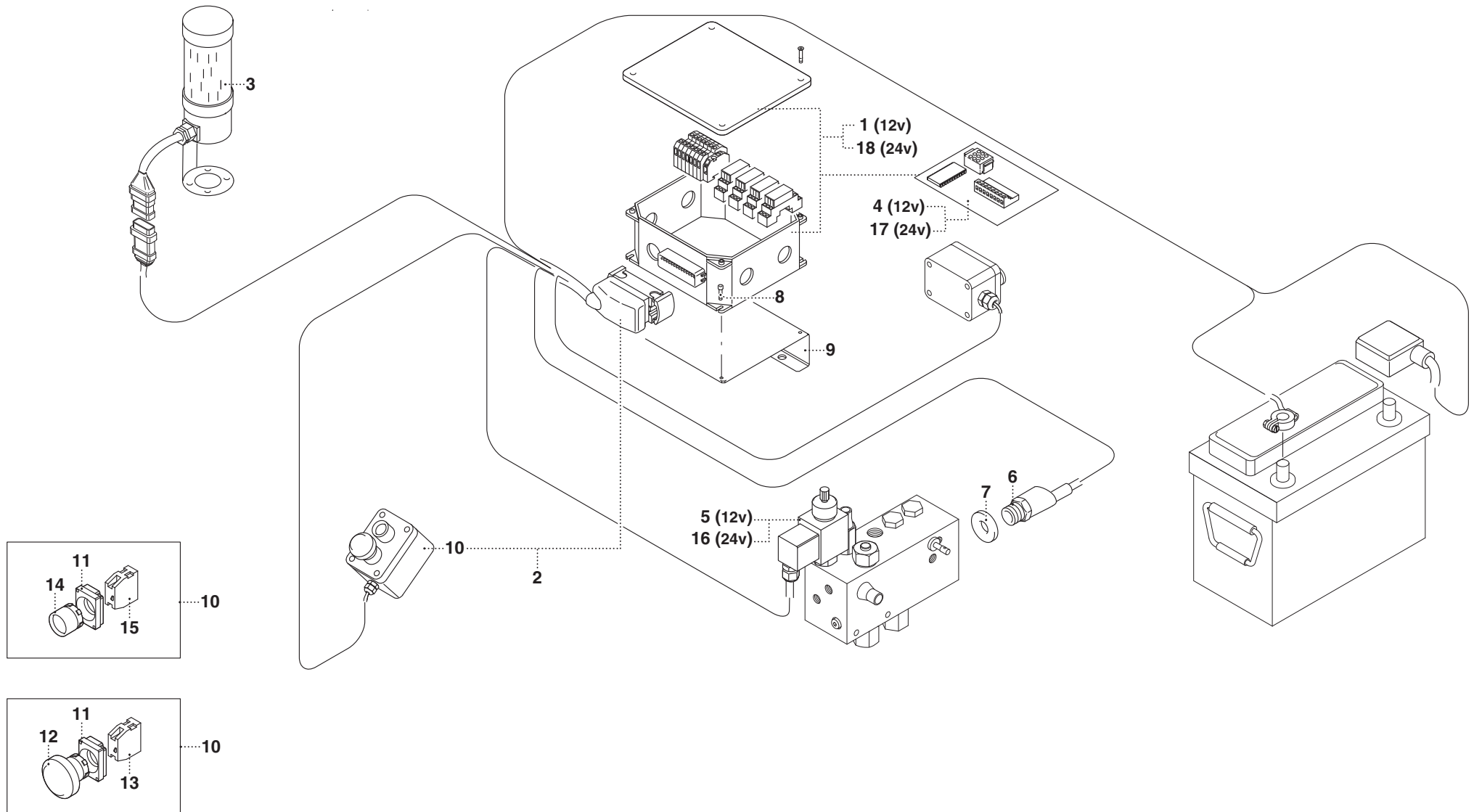

PM 21**matr. G107.0005****TAV. SX.02.03 1/2**

POS.	N° CODICE	Q.	DESCRIZIONE	DESIGNATION	BENENNUNG	DESCRIPTION	DENOMINACIONES
1	280731	1	SCATOLA	BOITE	GEHÄUSE	BOX	CAJA
2	280969	1	CABLAGGIO	CABLAGE	VERKABELUNG	SET WIRES	CABLEADO
3	280748	1	KIT LAMPEGGIATORE	KIT CLIGNOTANT	BLINKLICHTSATZ	FLASHLIGHT KIT	KIT INTERMITENTE
4	476065	1	SCHEDA	FICHE	KARTE	BOARD	ESQUELA
5	395379	1	BOBINA	BOBINE	SPULE	COIL	BOBINA
6	395830	1	PRESSOSTATO	PRESSOSTAT	DRUCKMESSER	PRESSURE SWITCH	PRESOSTATO
7	417096	1	RONDELLA	RONDELLE	SCHEIBE	WASHER	ARANDELA
8	497111	4	VITE	VIS	SCHRAUBE	SCREW	TORNILLO
9	467683	1	SUPPORTO	SUPPORT	TRÄGER	SUPPORT	SOPORTE
10	289568	1	KIT SCATOLA	KIT BOITE	GEHÄUSESATZ	BOX KIT	KIT CAJA
11	395599	2	FLANGIA	BRIDE	FLANSCH	FLANGE	BRIDA
12	395628	1	PULSANTE	BOUTON	TASTE	BUTTON	BOTON
13	395601	1	CONTATTO	CONTACT	KONTAKT	CONTACT	CONTACTO
14	395629	1	PULSANTE	BOUTON	TASTE	BUTTON	BOTON
15	395600	1	CONTATTO	CONTACT	KONTAKT	CONTACT	CONTACTO
16	395380	1	BOBINA	BOBINE	SPULE	COIL	BOBINA
17	476066	1	SCHEDA	FICHE	KARTE	BOARD	ESQUELA
18	280732	1	SCATOLA	BOITE	GEHÄUSE	BOX	CAJA



IMPIANTO ELETTRICO EMERGENZA- MACCHINA BASE - DANFOSS (ARGANO) (21)

- * Installation électrique urgence - machine standard - DANFOSS (treuil)
- * Not-Aus Vorrichtung Elektrischeanlage - Standardmaschine - DANFOSS (Winde)
- * Emergency electric system - Standard machine - DANFOSS (winch)
- * Instalación eléctrica emergencia - máquina base - DANFOSS (cabrestante)

TAV. SX.02.03 2/2

matr. G107.0005

21
23 P

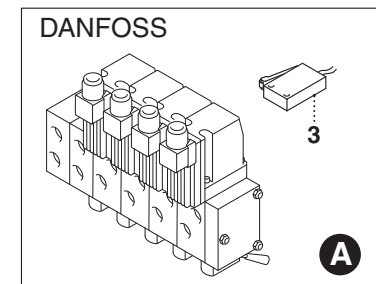
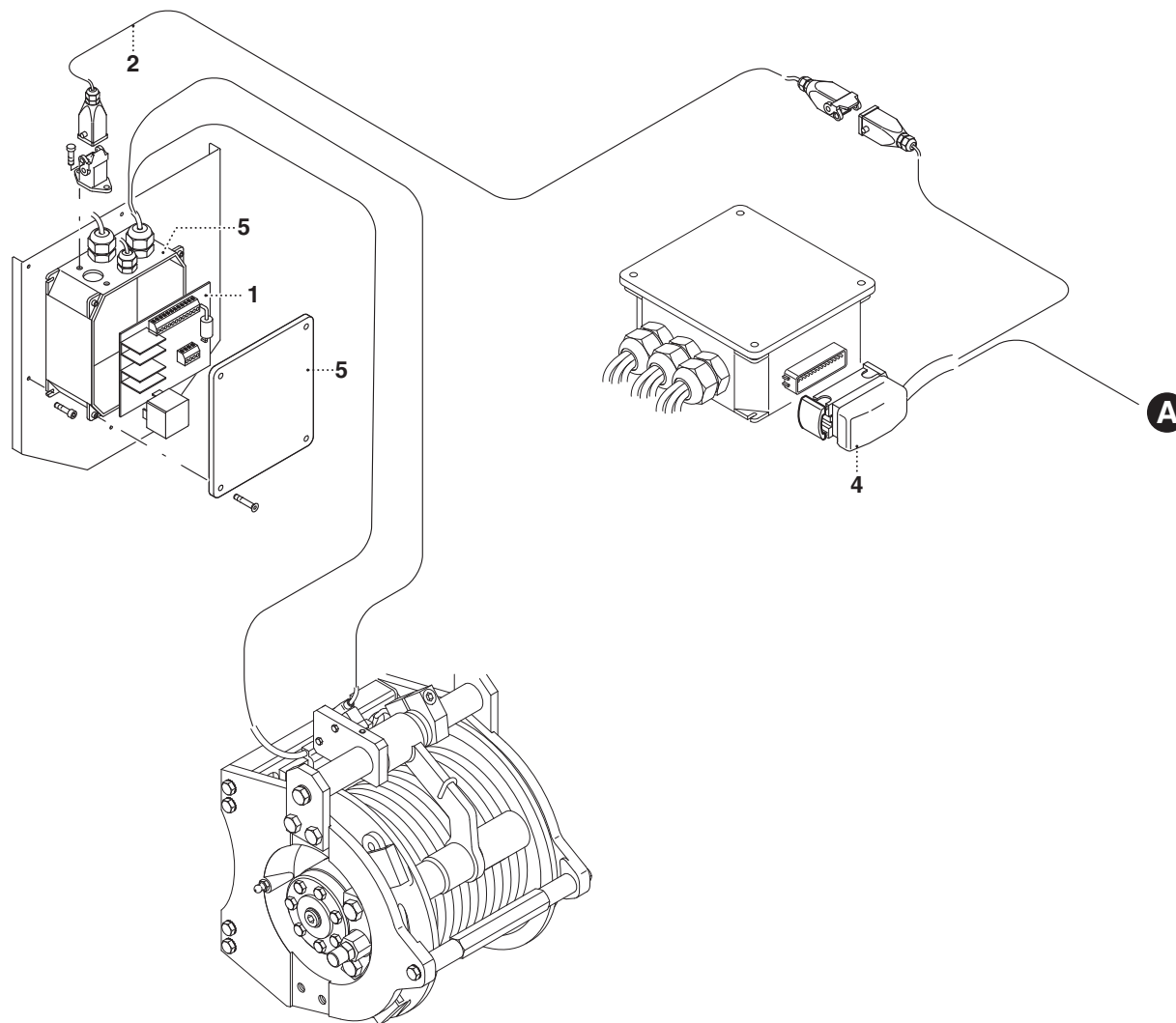



IMPIANTO ELETTRICO - MACCHINA BASE (23 P)

* Installation électrique - machine standard
* Standardmaschine - Elektrischeanlage
* Standard machine - electric system
* Instalación eléctrica máquina base

TAV. SX.03.01 1/2

matr. G107.0005

21
23 P

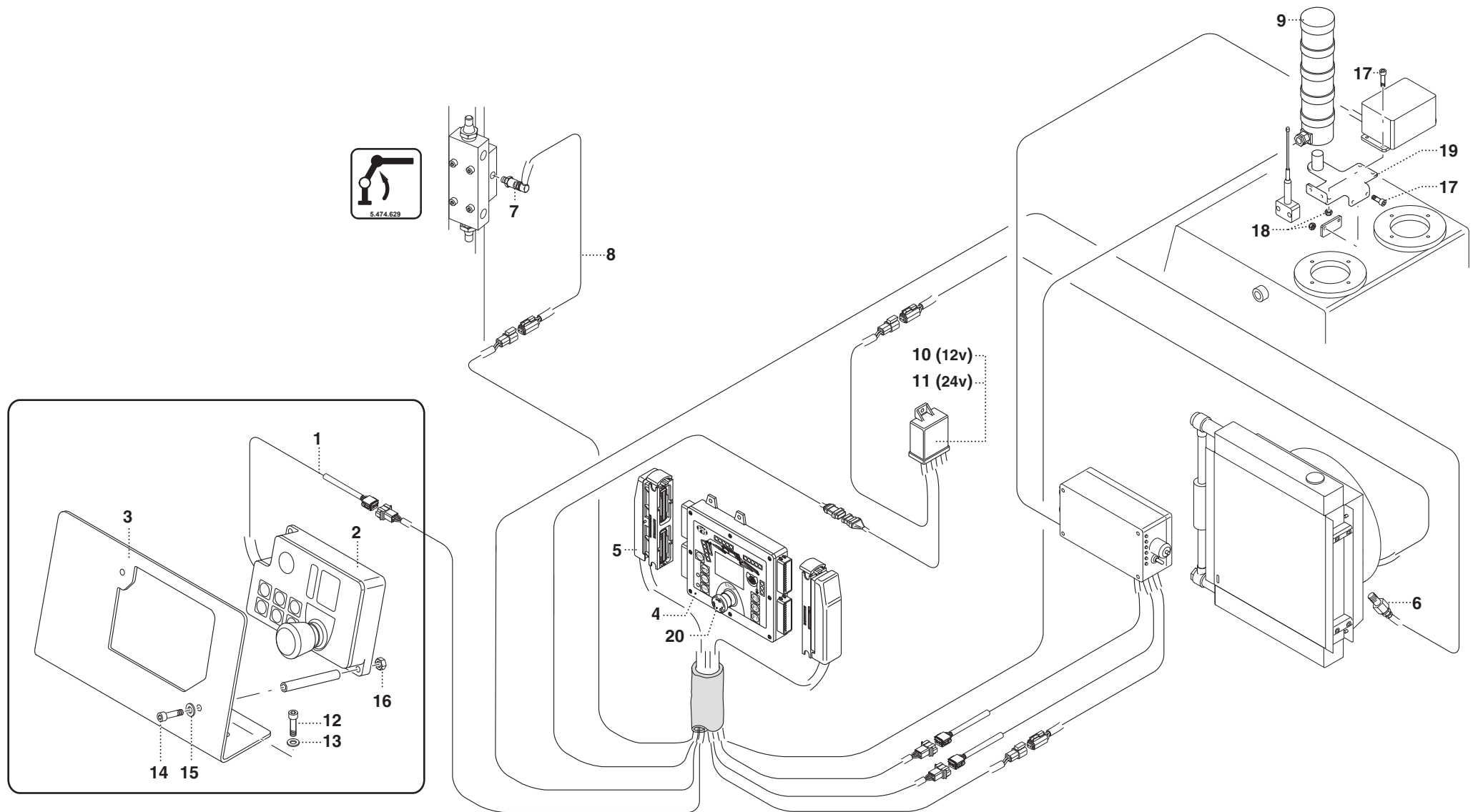

PM 23 P

matr. G107.0005

TAV. SX.03.01 1/2

POS.	N° CODICE	Q.	DESCRIZIONE	DESIGNATION	BENENNUNG	DESCRIPTION	DENOMINACIONES
1	280061	1	CABLAGGIO	CABLAGE	VERKABELUNG	SET WIRES	CABLEADO
2	476034	1	UNITA' DI CONTROLLO	UNITE CONTROLE	KONTROLLEINHEIT	CONTROL UNIT	UNIDAD CONTROL
3	176310	1	SUPPORTO	SUPPORT	TRÄGER	SUPPORT	SOPORTE
4	476032	1	UNITA' DI CONTROLLO	UNITE CONTROLE	KONTROLLEINHEIT	CONTROL UNIT	UNIDAD CONTROL
5	278085	1	CABLAGGIO	CABLAGE	VERKABELUNG	SET WIRES	CABLEADO
6	395643	1	SENSORE	CAPTEUR	SENSOR	SENSOR	SENSOR
7	395641	1	SENSORE DI PRESSIONE	CAPTEUR DE PRESSION	DRUCKSENSOR	PRESSURE SENSOR	SENSOR DE PRESION
8	280034	1	CABLAGGIO	CABLAGE	VERKABELUNG	SET WIRES	CABLEADO
9	280748	1	LAMPEGGIATORE	CLIGNOTANT	BLINKLICHT	FLASHLIGHT	INTERMITENTE
10	476051	1	DISPOSITIVO ACCENSIONE	DISPOSITIF ALLUMAGE	STARTVORRICHTUNG	IGNITION DEVICE	DISPOS. ENCENDIDO
11	476052	1	DISPOSITIVO ACCENSIONE	DISPOSITIF ALLUMAGE	STARTVORRICHTUNG	IGNITION DEVICE	DISPOS. ENCENDIDO
12	497238	2	VITE	VIS	SCHRAUBE	SCREW	TORNILLO
13	417025	2	RONDELLA	RONDELLE	SCHEIBE	WASHER	ARANDELA
14	497111	2	VITE	VIS	SCHRAUBE	SCREW	TORNILLO
15	417050	2	RONDELLA	RONDELLE	SCHEIBE	WASHER	ARANDELA
16	191046	2	DADO	ECROU	MUTTER	NUT	TUERCA
17	497119	6	VITE	VIS	SCHRAUBE	SCREW	TORNILLO
18	191125	1	DADO	ECROU	MUTTER	NUT	TUERCA
19	466594	1	SUPPORTO	SUPPORT	TRÄGER	SUPPORT	SOPORTE
20	395781	1	PULSANTE	BOUTON	TASTE	BUTTON	BOTON



IMPIANTO ELETTRICO - MACCHINA BASE - LG-A (23 P)

* Installation électrique - machine standard - LG-A
* Standardmaschine - Elektrischeanlage - LG-A
* Standard machine - electric system - LG-A
* Instalación eléctrica máquina base - LG-A

TAV. SX.03.01A 1/2

matr. C11930

21
23 P

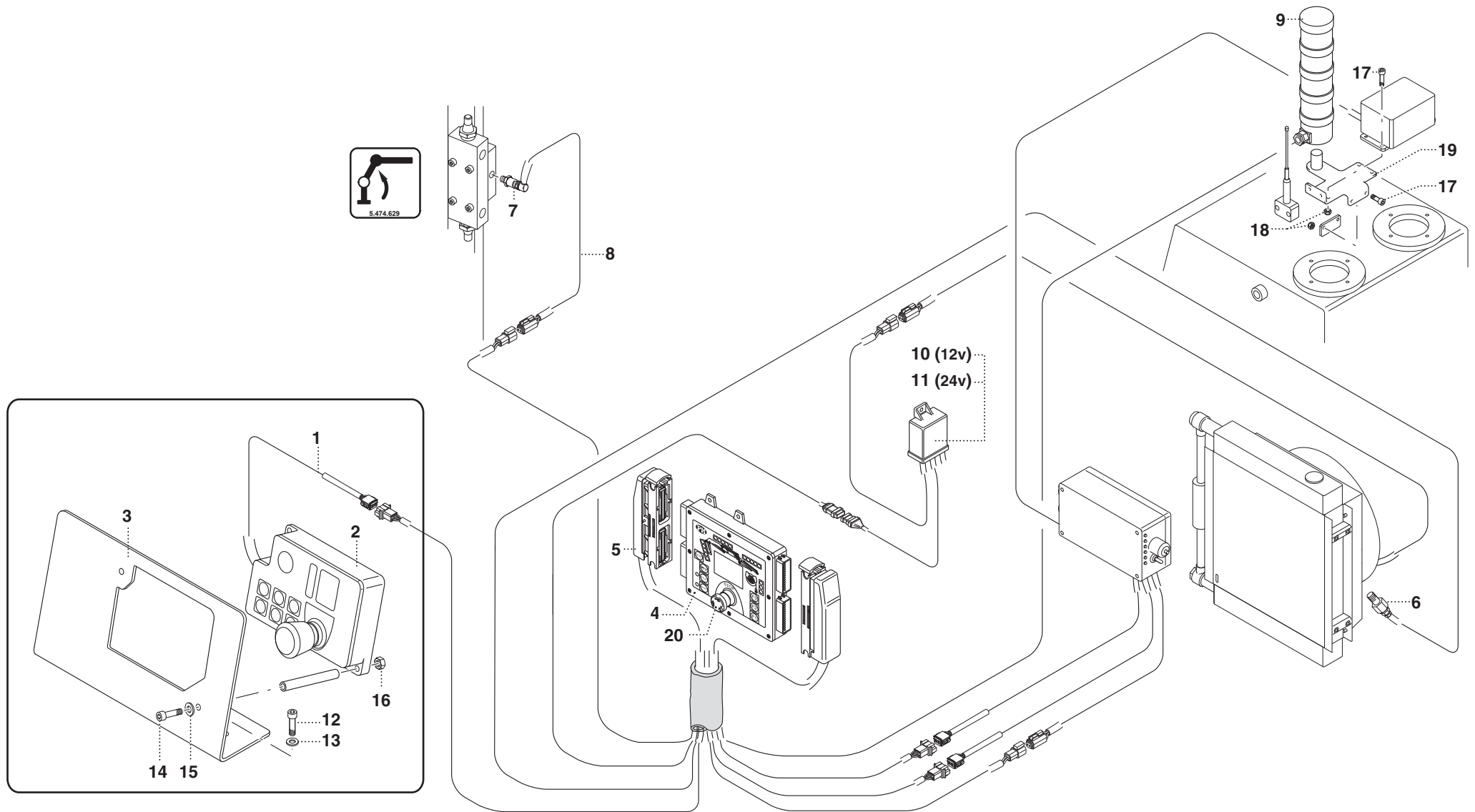

PM 23 P

matr. C11930

TAV. SX.03.01A 1/2

POS.	N° CODICE	Q.	DESCRIZIONE	DESIGNATION	BENENNUNG	DESCRIPTION	DENOMINACIONES
1	280061	1	CABLAGGIO	CABLAGE	VERKABELUNG	SET WIRES	CABLEADO
2	476034	1	UNITA' DI CONTROLLO	UNITE CONTROLE	KONTROLLEINHEIT	CONTROL UNIT	UNIDAD CONTROL
3	176310	1	SUPPORTO	SUPPORT	TRÄGER	SUPPORT	SOPORTE
4	476079	1	UNITA' DI CONTROLLO	UNITE CONTROLE	KONTROLLEINHEIT	CONTROL UNIT	UNIDAD CONTROL
5	394005	1	CABLAGGIO	CABLAGE	VERKABELUNG	SET WIRES	CABLEADO
6	395643	1	SENSORE	CAPTEUR	SENSOR	SENSOR	SENSOR
7	395641	1	SENSORE DI PRESSIONE	CAPTEUR DE PRESSION	DRUCKSENSOR	PRESSURE SENSOR	SENSOR DE PRESION
8	280297	1	CABLAGGIO	CABLAGE	VERKABELUNG	SET WIRES	CABLEADO
9	280748	1	LAMPEGGIATORE	CLIGNOTANT	BLINKLICHT	FLASHLIGHT	INTERMITENTE
10	476051	1	DISPOSITIVO ACCENSIONE	DISPOSITIF ALLUMAGE	STARTVORRICHTUNG	IGNITION DEVICE	DISPOS. ENCENDIDO
11	476052	1	DISPOSITIVO ACCENSIONE	DISPOSITIF ALLUMAGE	STARTVORRICHTUNG	IGNITION DEVICE	DISPOS. ENCENDIDO
12	497238	2	VITE	VIS	SCHRAUBE	SCREW	TORNILLO
13	417025	2	RONDELLA	RONDELLE	SCHEIBE	WASHER	ARANDELA
14	497111	2	VITE	VIS	SCHRAUBE	SCREW	TORNILLO
15	417050	2	RONDELLA	RONDELLE	SCHEIBE	WASHER	ARANDELA
16	191046	2	DADO	ECROU	MUTTER	NUT	TUERCA
17	497119	6	VITE	VIS	SCHRAUBE	SCREW	TORNILLO
18	191125	1	DADO	ECROU	MUTTER	NUT	TUERCA
19	466594	1	SUPPORTO	SUPPORT	TRÄGER	SUPPORT	SOPORTE
20	395781	1	PULSANTE	BOUTON	TASTE	BUTTON	BOTON



IMPIANTO ELETTRICO - MACCHINA BASE (23 P)

* Installation électrique - machine standard
* Standardmaschine - Elektrischeanlage
* Standard machine - electric system
* Instalación eléctrica máquina base

TAV. SX.03.01 2/2

matr. G107.0005

21
23 P

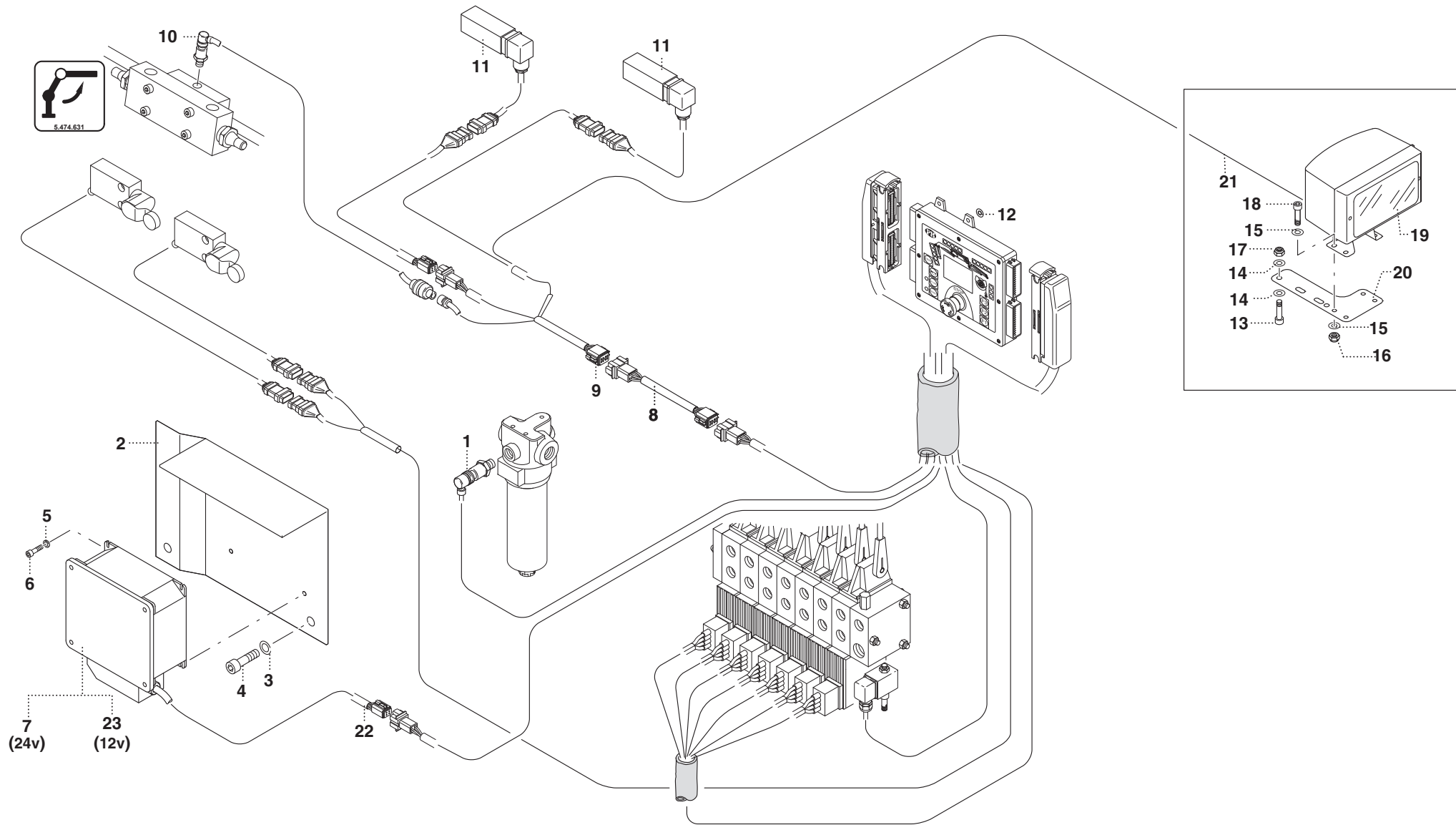

PM 23 P**matr. G107.0005****TAV. SX.03.01 2/2**

POS.	N° CODICE	Q.	DESCRIZIONE	DESIGNATION	BENENNUNG	DESCRIPTION	DENOMINACIONES
1	395632	1	SENSORE	CAPTEUR	SENSOR	SENSOR	SENSOR
2	466974	1	SUPPORTO	SUPPORT	TRÄGER	SUPPORT	SOPORTE
3	417026	2	RONDELLA	RONDELLE	SCHEIBE	WASHER	ARANDELA
4	497381	2	VITE	VIS	SCHRAUBE	SCREW	TORNILLO
5	417002	4	RONDELLA	RONDELLE	SCHEIBE	WASHER	ARANDELA
6	497111	4	VITE	VIS	SCHRAUBE	SCREW	TORNILLO
7	280933	1	KIT SCATOLA	KIT BOITE	GEHÄUSESATZ	BOX KIT	KIT CAJA
8	280041	1	CABLAGGIO	CABLAGE	VERKABELUNG	SET WIRES	CABLEADO
9	280042	1	CABLAGGIO	CABLAGE	VERKABELUNG	SET WIRES	CABLEADO
10	395641	1	SENSORE DI PRESSIONE	CAPTEUR DE PRESSION	DRUCKSENSOR	PRESSURE SENSOR	SENSOR DE PRESION
11	395731	2	SENSORE ANGOLARE	CAPTEUR CORNIERE	WINKELSENSOR	ANGLE SENSOR	SENSOR ANGULAR
12	262036	4	SPESSORE	EPAISSEUR	DICKE	THICKNESS	ESPEJOR
13	497138	2	VITE	VIS	SCHRAUBE	SCREW	TORNILLO
14	417004	4	RONDELLA	RONDELLE	SCHEIBE	WASHER	ARANDELA
15	417003	8	RONDELLA	RONDELLE	SCHEIBE	WASHER	ARANDELA
16	191125	4	DADO	ECROU	MUTTER	NUT	TUERCA
17	191168	2	DADO	ECROU	MUTTER	NUT	TUERCA
18	497119	4	VITE	VIS	SCHRAUBE	SCREW	TORNILLO
19	395798	1	FANALE	FEU	SCHEINWERFER	LIGHT	FARO
20	467329	1	LAMIERA	TOLE	BLECH	PLATE	LAMINA
21	280460	1	CABLAGGIO	CABLAGE	VERKABELUNG	SET WIRES	CABLEADO
22	280931	1	CABLAGGIO	CABLAGE	VERKABELUNG	SET WIRES	CABLEADO
23	280932	1	KIT SCATOLA	KIT BOITE	GEHÄUSESATZ	BOX KIT	KIT CAJA



IMPIANTO ELETTRICO - PROLUNGA ARTICOLATA (23 P)

- * Installation électrique - rallonge articulée
- * Gelenkverlängerung - Elektrischeanlage
- * Jib - electric system
- * Instalación eléctrica extensión articulada

TAV. SX.04.01

matr. G107.0005

21
23 P

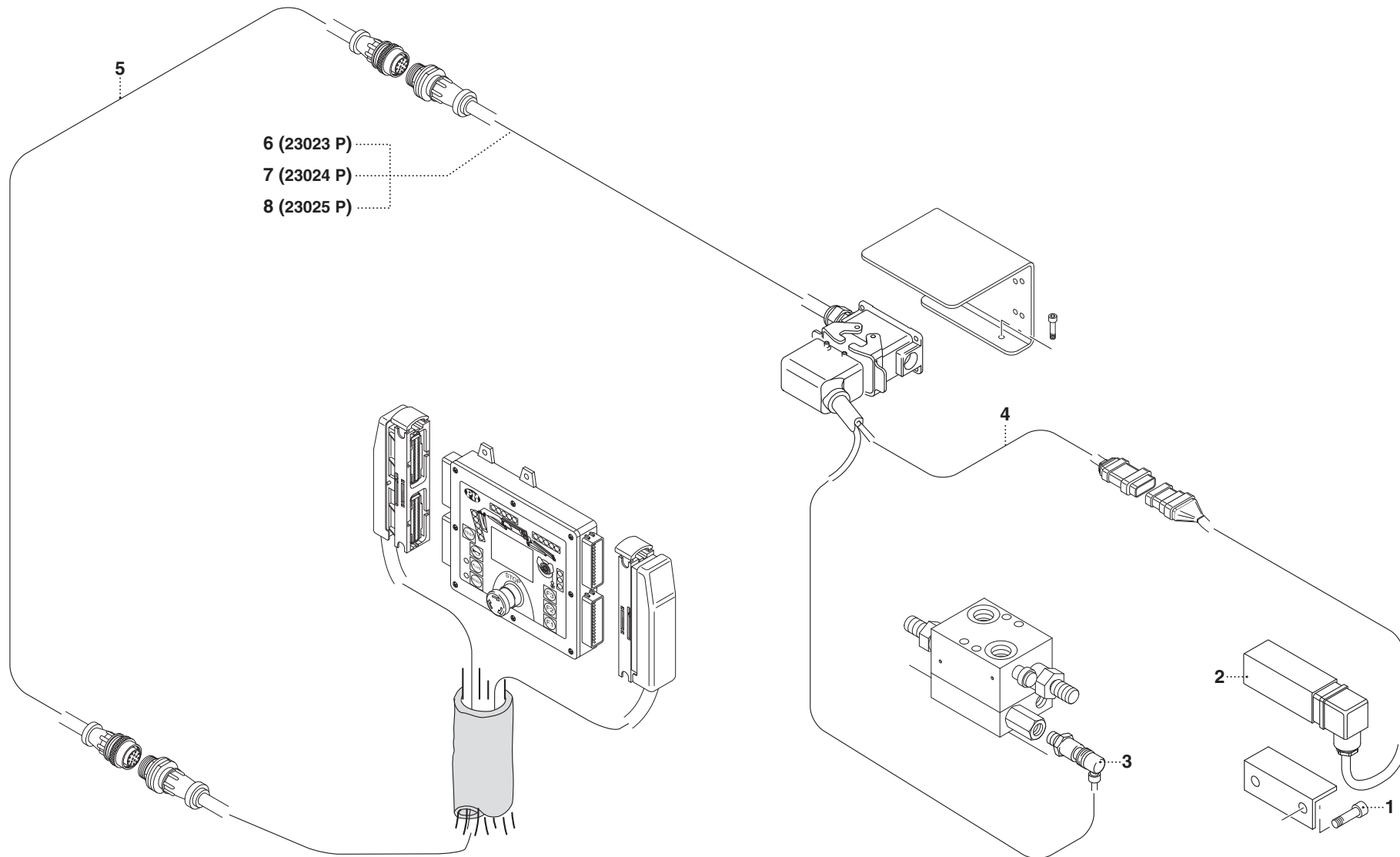

PM 23 P

matr. G107.0005

TAV. SX.04.01

POS.	N° CODICE	Q.	DESCRIZIONE	DESIGNATION	BENENNUNG	DESCRIPTION	DENOMINACIONES
1	497233	2	VITE	VIS	SCHRAUBE	SCREW	TORNILLO
2	395731	1	SENSORE ANGOLARE	CAPTEUR CORNIERE	WINKELSENSOR	ANGLE SENSOR	SENSOR ANGULAR
3	395641	1	SENSORE DI PRESSIONE	CAPTEUR DE PRESSION	DRUCKSENSOR	PRESSURE SENSOR	SENSOR DE PRESION
4	280058	1	CABLAGGIO	CABLAGE	VERKABELUNG	SET WIRES	CABLEADO
5	280059	1	CABLAGGIO	CABLAGE	VERKABELUNG	SET WIRES	CABLEADO
6	280934	1	CABLAGGIO	CABLAGE	VERKABELUNG	SET WIRES	CABLEADO
7	280935	1	CABLAGGIO	CABLAGE	VERKABELUNG	SET WIRES	CABLEADO
8	280936	1	CABLAGGIO	CABLAGE	VERKABELUNG	SET WIRES	CABLEADO



IMPIANTO ELETTRICO ARGANO (23 P)

* Installation électrique treuil
* Windeelektrischeanlage
* Winch electric system
* Instalación eléctrica cabrestante

TAV. SX.05.01

matr. G107.0005

21
23 P

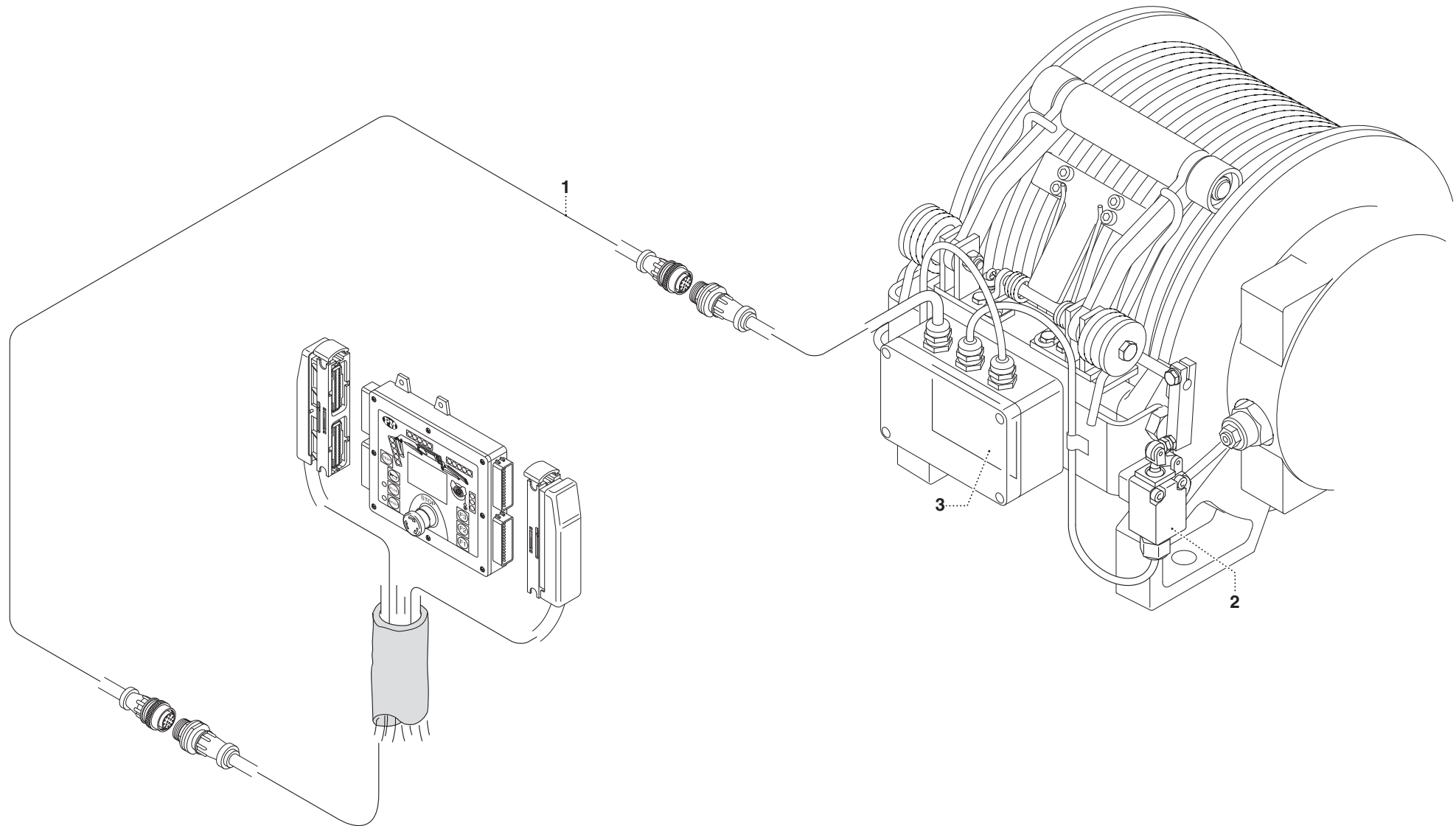



IMPIANTO ELETTRICO ARGANO TC1 - PROLUNGA ARTICOLATA (23 P)

* Installation électrique treuil TC1 - rallonge articulée
* TC1 Winde - Gelenkverlängerung Elektrischeanlage
* TC1 winch - jib - electric system
* Instalación eléctrica cabrestante TC1 - extensión articulada

TAV. SX.06.02

matr. G107.0005

21
23 P

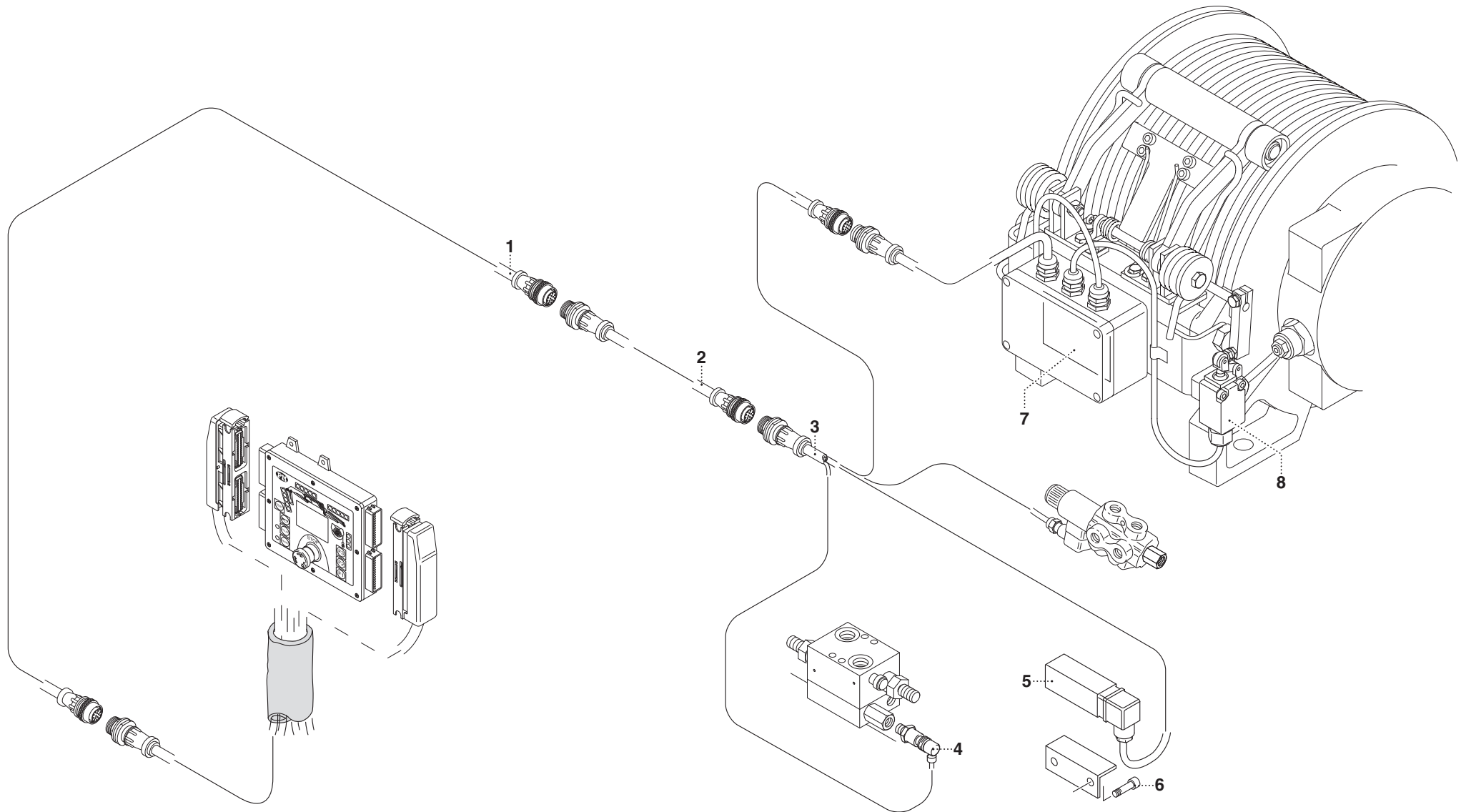



IMPIANTO ELETTRICO STABILIZZATORI "MCS" (23 P)

* Installation électrique stabilisateurs "MCS"
* Stützeelektrischeanlage "MCS"
* Outriggers electric system "MCS"
* Instalación eléctrica estabilizadores "MCS"

TAV. SX.07.01

matr. G107.0005

21
23 P

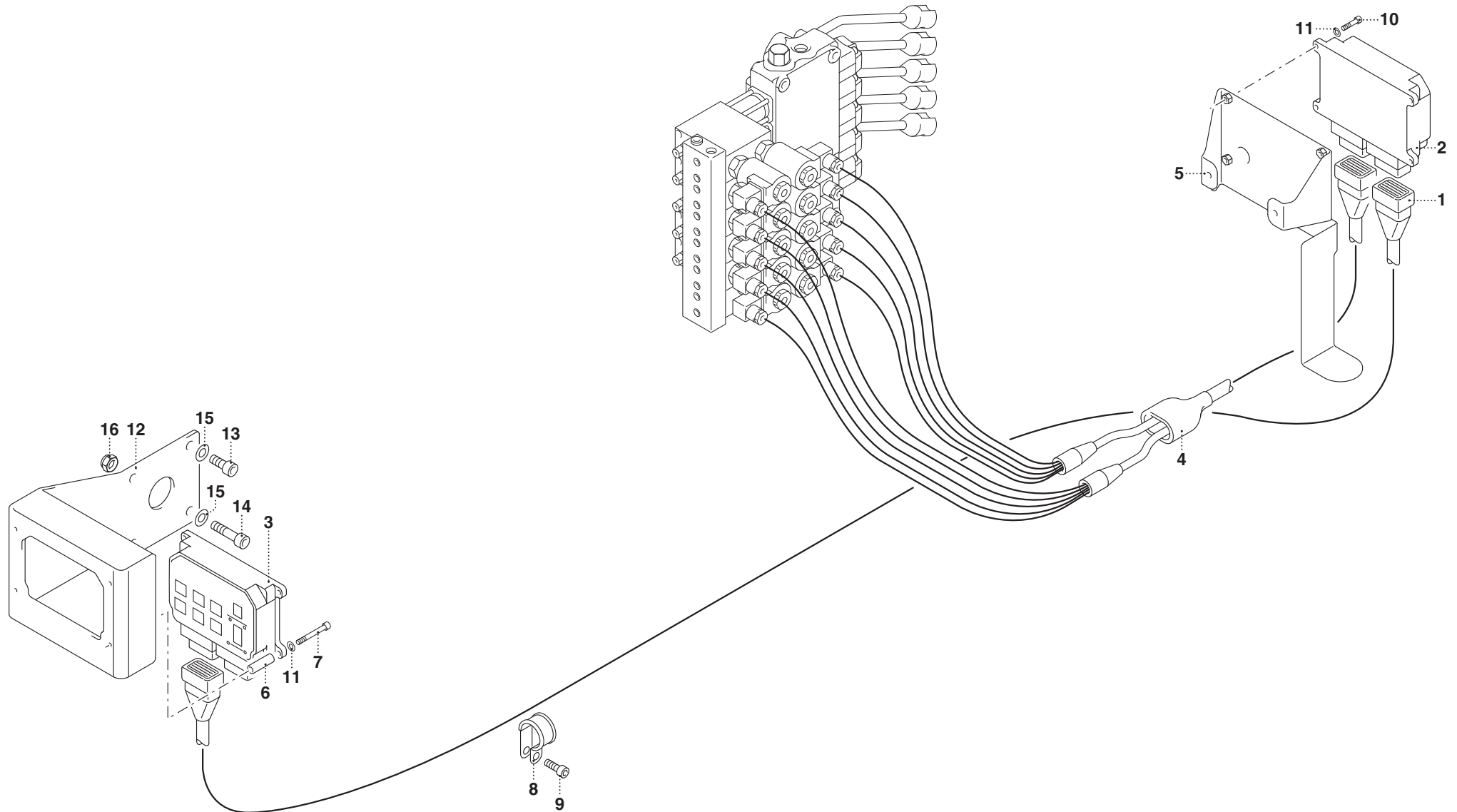

PM 23 P**matr. G107.0005****TAV. SX.07.01**

POS.	N° CODICE	Q.	DESCRIZIONE	DESIGNATION	BENENNUNG	DESCRIPTION	DENOMINACIONES
1	278086	1	CABLAGGIO	CABLAGE	VERKABELUNG	SET WIRES	CABLEADO
2	476072	1	CENTRALINA	DISPOSITIF DE COMM.	STEUERGEHÄUSE	CONTROL UNIT	CENTRAL
3	476073	1	CENTRALINA	DISPOSITIF DE COMM.	STEUERGEHÄUSE	CONTROL UNIT	CENTRAL
4	278052	1	CABLAGGIO	CABLAGE	VERKABELUNG	SET WIRES	CABLEADO
5	467582	1	SUPPORTO	SUPPORT	TRÄGER	SUPPORT	SOPORTE
6	139067	4	BOCCOLA	DOUILLE	BUCHSE	BUSHING	CASQUILLO
7	497113	4	VITE	VIS	SCHRAUBE	SCREW	TORNILLO
8	353062	1	MORSETTO	ETAU	KLEMME	CLAMP	PRENSOR
9	497117	1	VITE	VIS	SCHRAUBE	SCREW	TORNILLO
10	497486	4	VITE	VIS	SCHRAUBE	SCREW	TORNILLO
11	417002	8	RONDELLA	RONDELLE	SCHEIBE	WASHER	ARANDELA
12	467667	1	SUPPORTO	SUPPORT	TRÄGER	SUPPORT	SOPORTE
13	497144	2	VITE	VIS	SCHRAUBE	SCREW	TORNILLO
14	497147	2	VITE	VIS	SCHRAUBE	SCREW	TORNILLO
15	417026	4	RONDELLA	RONDELLE	SCHEIBE	WASHER	ARANDELA
16	191045	2	DADO	ECROU	MUTTER	NUT	TUERCA



SCAMBIATORE DI CALORE - HYDROCONTROL (MANUALE) (21)

- * Echangeur chaleur - HYDROCONTROL (manuel)
- * Wärmeaustauscher - HYDROCONTROL (manuelle)
- * Heat exchanger - HYDROCONTROL (manual)
- * Intercambiador calor - HYDROCONTROL (manual)

TAV. SX.08.01

matr. G107.0005

21
23 P

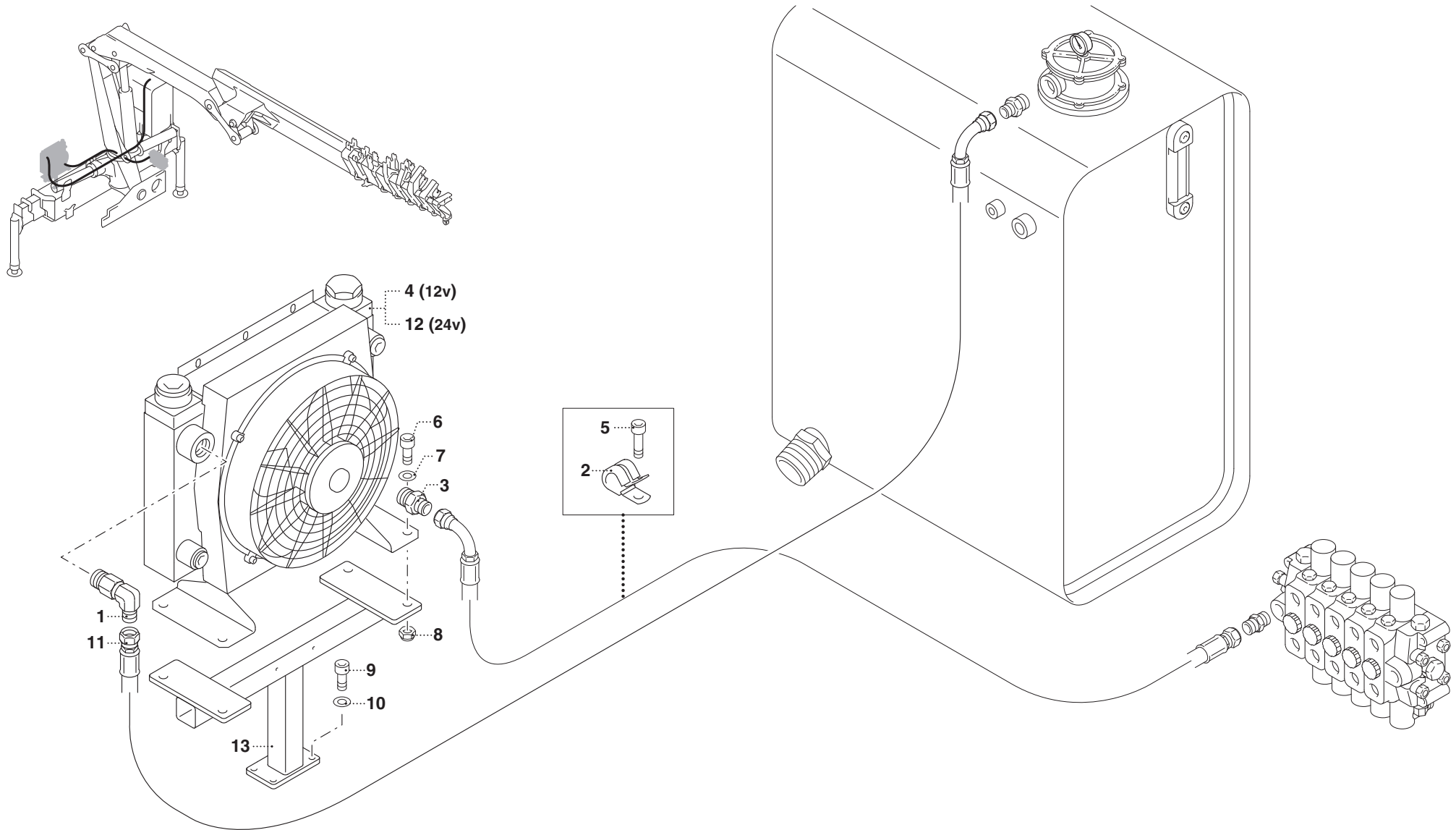

PM 21**matr. G107.0005****TAV. SX.08.01**

POS.	N° CODICE	Q.	DESCRIZIONE	DESIGNATION	BENENNUNG	DESCRIPTION	DENOMINACIONES
1	409116	1	RACCORDO	RACCORD	ANSCHLUSS	FITTING	RACOR
2	353110	1	MORSETTO	ETAU	KLEMME	CLAMP	PRENSOR
3	409425	1	RACCORDO	RACCORD	ANSCHLUSS	FITTING	RACOR
4	619434	1	SCAMBIATORE CALORE	ECHANGEUR CHALEUR	WÄRMEAUSTAUSCHER	HEAT EXCHANGER	INTERCAMB. CALOR
5	497225	1	VITE	VIS	SCHRAUBE	SCREW	TORNILLO
6	497382	4	VITE	VIS	SCHRAUBE	SCREW	TORNILLO
7	417005	4	RONDELLA	RONDELLE	SCHEIBE	WASHER	ARANDELA
8	191045	4	DADO	ECROU	MUTTER	NUT	TUERCA
9	497130	4	VITE	VIS	SCHRAUBE	SCREW	TORNILLO
10	417025	4	RONDELLA	RONDELLE	SCHEIBE	WASHER	ARANDELA
11	482527	1	TUBO FLESSIBILE	TUYAU FLEXIBLE	SCHLAUCH	FLEXIBLE HOSE	TUBO FLEXIBLE
12	619435	1	SCAMBIATORE CALORE	ECHANGEUR CHALEUR	WÄRMEAUSTAUSCHER	HEAT EXCHANGER	INTERCAMB. CALOR
13	467410	1	SUPPORTO	SUPPORT	TRÄGER	SUPPORT	SOPORTE



SCAMBIATORE DI CALORE - DANFOSS - HYDROCONTROL (RADIOCOMANDO)

- * Echangeur chaleur - DANFOSS -HYDROCONTROL (radiocommande)
- * Warmeaustauscher - DANFOSS -HYDROCONTROL (Fernsteuerung)
- * Heat exchanger - DANFOSS -HYDROCONTROL (radio control)
- * Intercambiador calor - DANFOSS -HYDROCONTROL (radio mando)

TAV. SX.08.02

matr. G107.0005

21
23 P

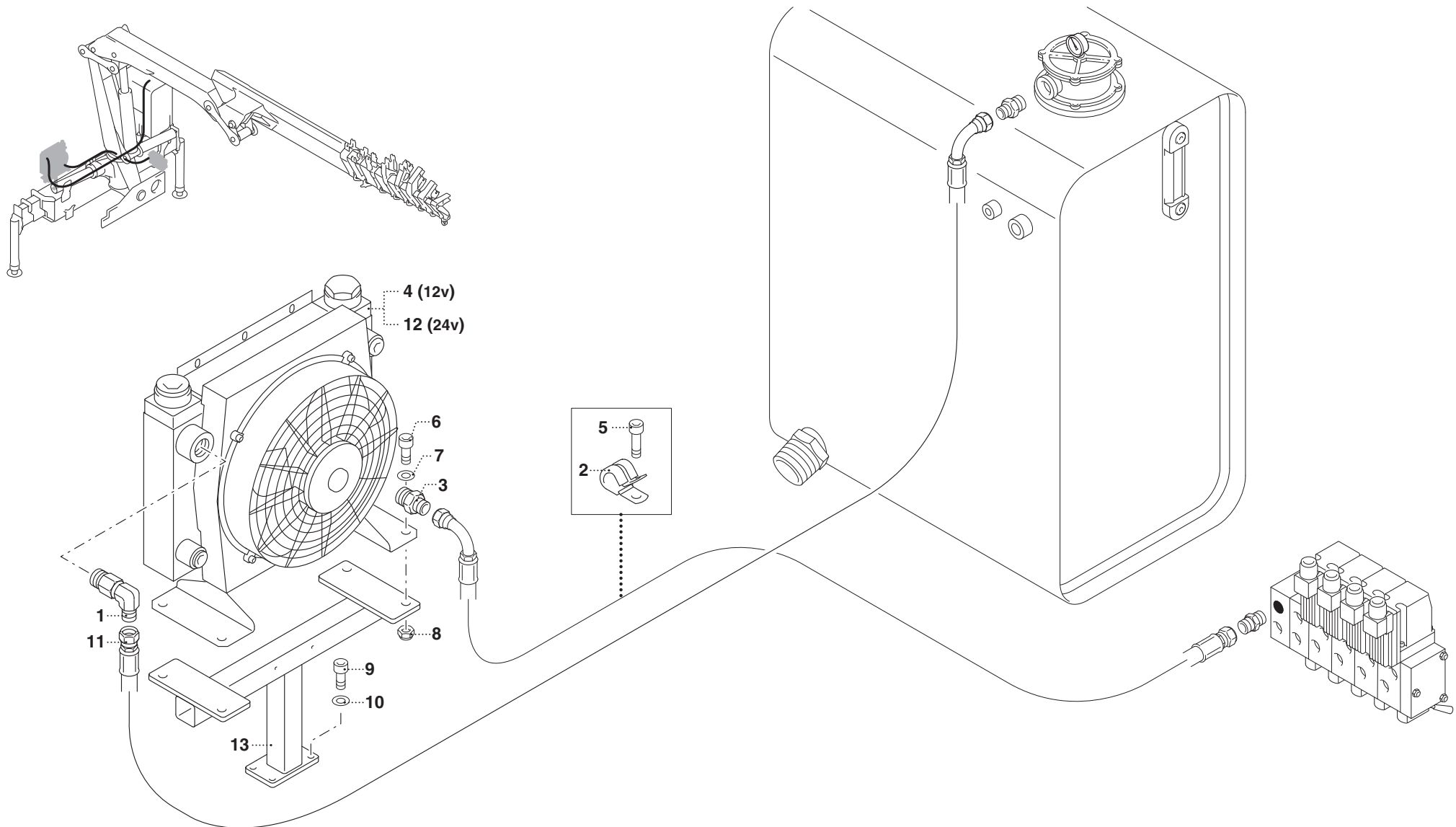

PM 21 - PM 23 P

matr. G107.0005

TAV. SX.08.02

POS.	N° CODICE	Q.	DESCRIZIONE	DESIGNATION	BENENNUNG	DESCRIPTION	DENOMINACIONES
1	409116	1	RACCORDO	RACCORD	ANSCHLUSS	FITTING	RACOR
2	353110	1	RACCORDO	RACCORD	ANSCHLUSS	FITTING	RACOR
3	409425	1	RACCORDO	RACCORD	ANSCHLUSS	FITTING	RACOR
4	619430	1	SCAMBIATORE CALORE	ECHANGEUR CHALEUR	WÄRMEAUSTAUSCHER	HEAT EXCHANGER	INTERCAMB. CALOR
5	497225	1	VITE	VIS	SCHRAUBE	SCREW	TORNILLO
6	497382	4	VITE	VIS	SCHRAUBE	SCREW	TORNILLO
7	417005	4	RONDELLA	RONDELLE	SCHEIBE	WASHER	ARANDELA
8	191045	4	DADO	ECROU	MUTTER	NUT	TUERCA
9	497130	4	VITE	VIS	SCHRAUBE	SCREW	TORNILLO
10	417025	4	RONDELLA	RONDELLE	SCHEIBE	WASHER	ARANDELA
11	482527	1	TUBO FLESSIBILE	TUYAU FLEXIBLE	SCHLAUCH	FLEXIBLE HOSE	TUBO FLEXIBLE
12	619431	1	SCAMBIATORE CALORE	ECHANGEUR CHALEUR	WÄRMEAUSTAUSCHER	HEAT EXCHANGER	INTERCAMB. CALOR
13	467410	1	SUPPORTO	SUPPORT	TRÄGER	SUPPORT	SOPORTE



SERBATOIO OLIO - 3° PUNTO DI MANOVRA

- * Réservoir d'huile - 3ème point de manœuvre
- * Ölbehälter - 3. Manöverplatz
- * Oil tank - 3rd manoeuvre position
- * Deposito aceite - 3er punto de maniobra

TAV. SX.09.01

matr. G107.0005

21
23 P

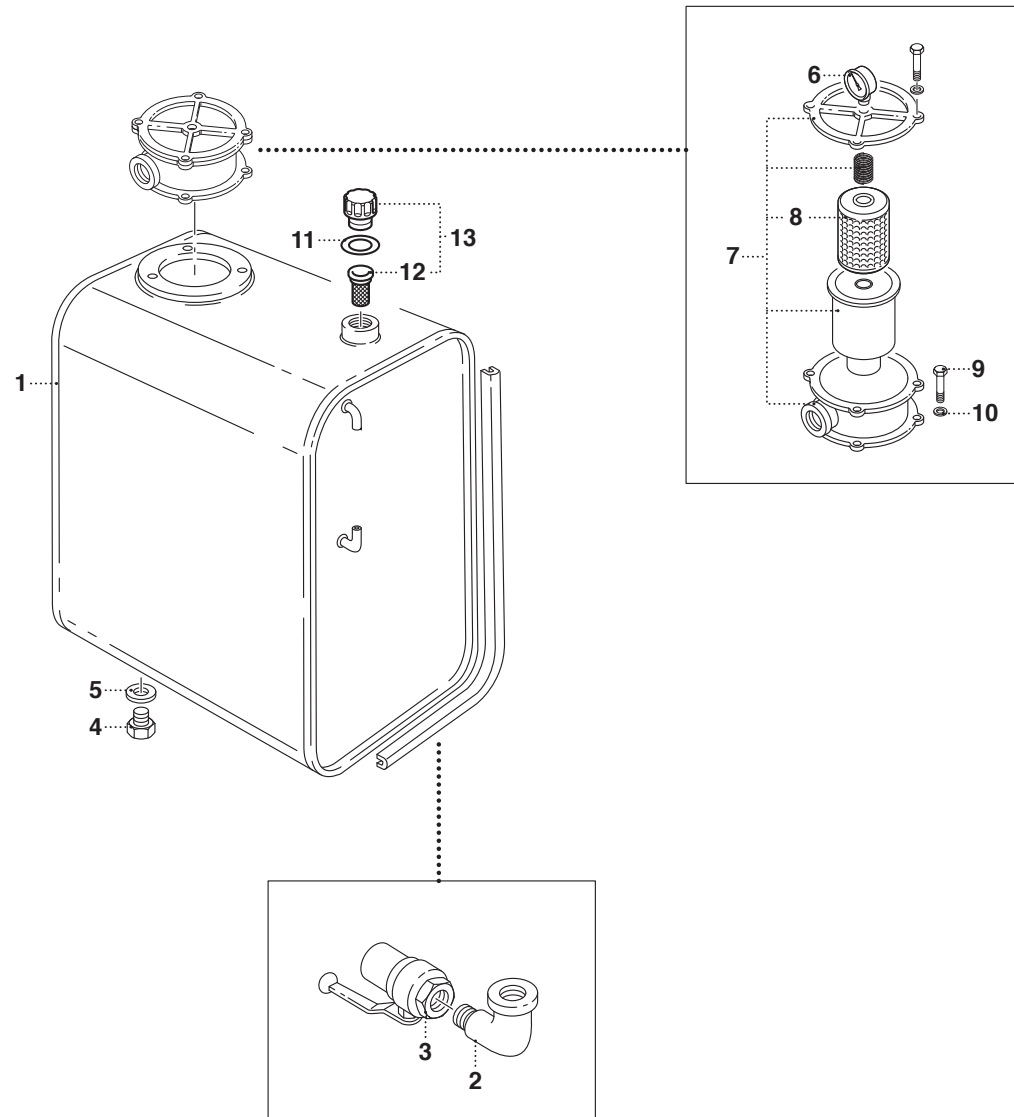

PM 21 - PM 23 P**matr. G107.0005****TAV. SX.09.01**

POS.	N° CODICE	Q.	DESCRIZIONE	DESIGNATION	BENENNUNG	DESCRIPTION	DENOMINACIONES
1	443090	1	SERBATOIO	RESERVOIR	TANK	TANK	DEPOSITO
2	185005	1	RACCORDO	RACCORD	ANSCHLUSS	FITTING	RACOR
3	421020	1	RUBINETTO	ROBINET	HAHN	COCK	GRIFO
4	471029	1	TAPPO	BOUCHON	VERSCHLUSSDECKEL	PLUG	TAPON
5	417087	1	RONDELLA	RONDELLE	SCHEIBE	WASHER	ARANDELA
6	355010	1	MANOMETRO	MANOMETRE	DRUCKMESSER	GAUGE	MANOMETRO
7	215076	1	FILTRO	FILTRE	FILTER	FILTER	FILTRO
8	149065	1	CARTUCCIA FILTRANTE	CARTOUCHE FILTRANTE	FILTREINSATZ	FILTERING CARTRIDGE	CARTUCHO FILTRANTE
9	497025	2	VITE	VIS	SCHRAUBE	SCREW	TORNILLO
10	417004	2	RONDELLA	RONDELLE	SCHEIBE	WASHER	ARANDELA
11	417088	1	RONDELLA	RONDELLE	SCHEIBE	WASHER	ARANDELA
12	149071	1	CARTUCCIA FILTRANTE	CARTOUCHE FILTRANTE	FILTREINSATZ	FILTERING CARTRIDGE	CARTUCHO FILTRANTE
13	215075	1	FILTRO	FILTRE	FILTER	FILTER	FILTRO



RADIOCOMANDO - SCANRECO 6F (397001) - DANFOSS (21)

- * Radiocommande - SCANRECO 6F - DANFOSS
- * Funksteuerung - SCANRECO 6F - DANFOSS
- * Radio control - SCANRECO 6F - DANFOSS
- * Radiocontrol - SCARECO 6F - DANFOSS

TAV. SY.01.01

matr. G107.0005

21
23 P

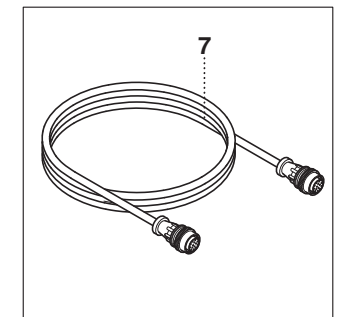
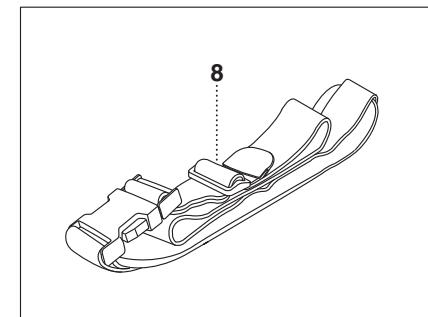
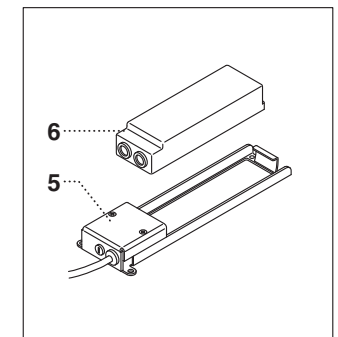
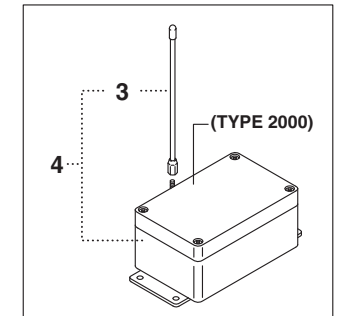
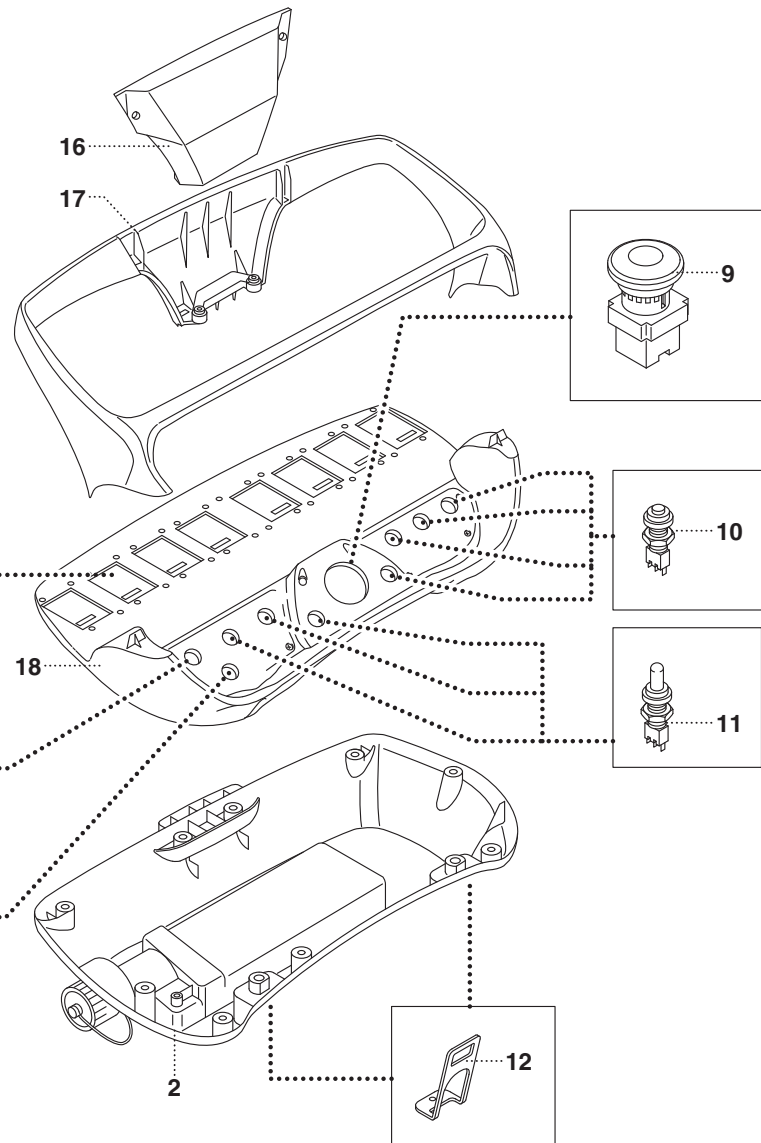
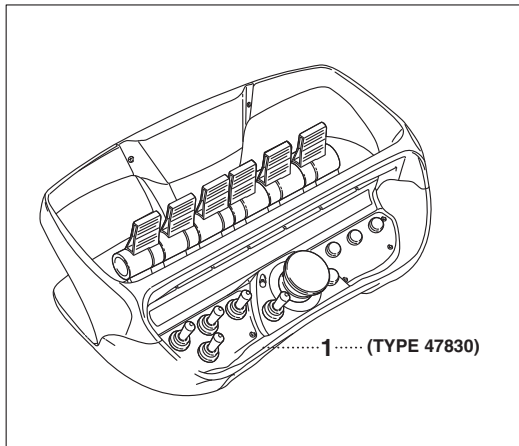

PM 21**matr. G107.0005****TAV. SY.01.01**

POS.	N° CODICE	Q.	DESCRIZIONE	DESIGNATION	BENENNUNG	DESCRIPTION	DENOMINACIONES
1	510978	1	UNITA' TRASMITTENTE	UNITE EMETTRICE	SENDEREINHEIT	TRANSMITTER UNIT	UNIDAD TRANSMISORA
2	510850	1	CORPO RADIOCOMANDO	CORPS RADIOCOMMANDE	FUNKSTEUERUNGSGEHÄUSE	RADIO CONTROL BODY	CUERPO RADIOCONTROL
3	510976	1	ANTENNA	ANTENNE	ANTENNE	ANTENNA	ANTENA
4	510997	1	UNITA' RICEVENTE	UNITE RECEPTRICE	EMPFANGSEINHEIT	RECEIVER UNIT	UNIDAD RECEPTORA
5	510581	1	CARICABATTERIA	CHARGEUR BATTERIE	BATTERIELADEGERÄT	BATTERY CHARGER	CARGADOR BATERIA
6	510582	1	BATTERIA	BATTERIE	BATTERIE	BATTERY	BATERIA
7	510977	1	CAVO	CABLE	KABEL	CABLE	CABLE
8	510755	1	CINGHIA	COURROIE	RIEMEN	BELT	CORREA
9	510585	1	PULSANTE	BOUTON	TASTE	BUTTON	BOTON
10	510885	1	PULSANTE	BOUTON	TASTE	BUTTON	BOTON
11	510756	1	INTERRUTTORE	INTERRUPTEUR	SCHALTER	SWITCH	INTERRUPTOR
12	510890	1	GANCIO	CROCHET	HAKEN	HOOK	GANCHO
13	510883	1	INTERRUTTORE	INTERRUPTEUR	SCHALTER	SWITCH	INTERRUPTOR
14	510884	1	INTERRUTTORE	INTERRUPTEUR	SCHALTER	SWITCH	INTERRUPTOR
15	510586	1	LEVA	LEVIER	HEBEL	LEVER	PALANCA
16	510874	1	COPERCHIO	COUVERCLE	DECKEL	COVER	TAPA
17	510882	1	COPERCHIO	COUVERCLE	DECKEL	COVER	TAPA
18	510881	1	COPERCHIO	COUVERCLE	DECKEL	COVER	TAPA



RADIOCOMANDO - SCANRECO 6F (470491) - STD (23 P)

* Radiocommande - SCANRECO 6F (470491) - STD
* Funksteuerung - SCANRECO 6F (470491) - STD
* Radio control - SCANRECO 6F (470491) - STD
* Radiocontrol - SCARECO 6F (470491) - STD

TAV. SY.01.02

matr. G107.0005

21
23 P

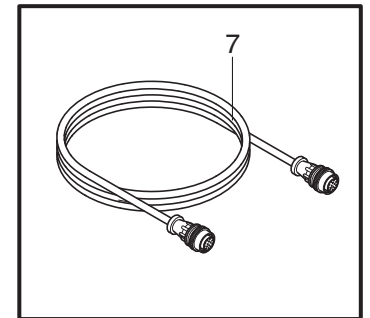
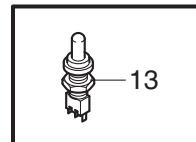
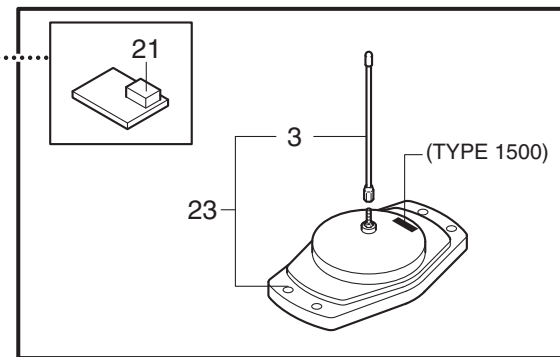
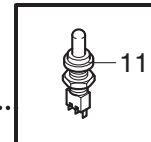
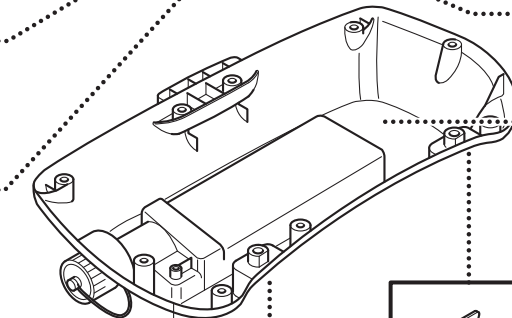
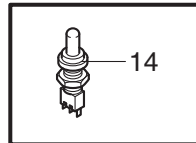
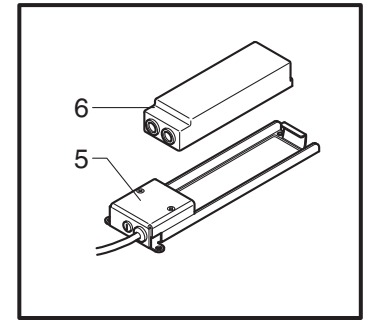
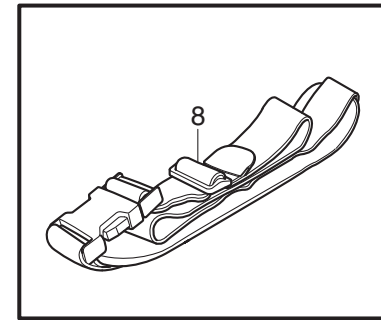
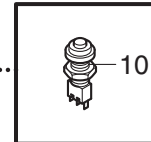
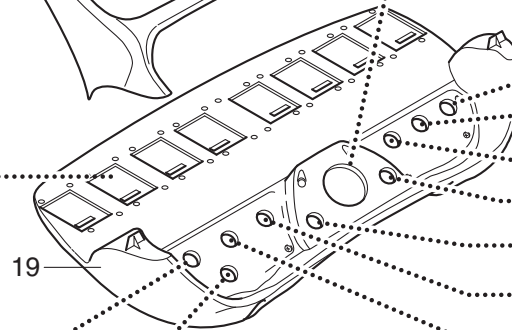
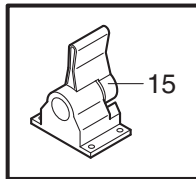
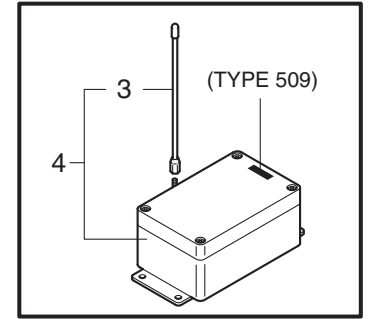
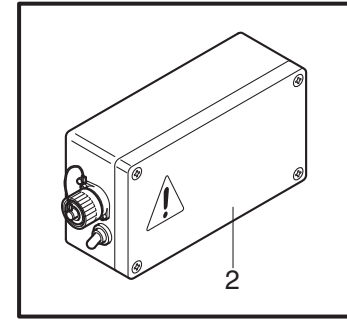
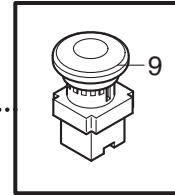
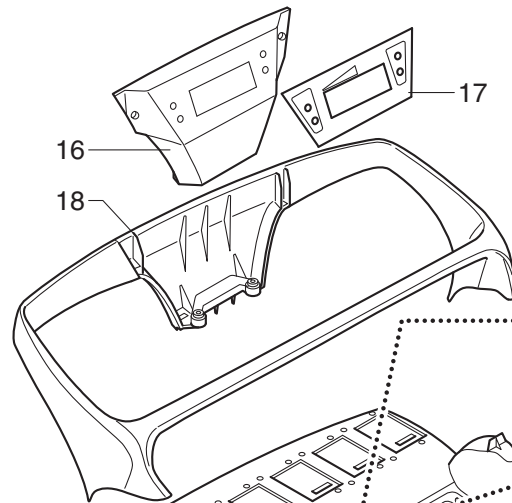
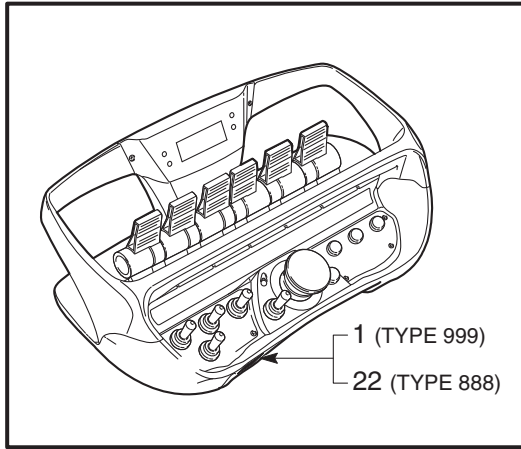

PM 23 P

matr. G107.0005

TAV. SY.01.02

POS.	N° CODICE	Q.	DESCRIZIONE	DESIGNATION	BENENNUNG	DESCRIPTION	DENOMINACIONES
1	510852	1	UNITA' TRASMITTENTE	UNITE EMETTRICE	SENDEREINHEIT	TRANSMITTER UNIT	UNIDAD TRANSMISORA
2	510853	1	UNITA' CENTRALE	UNITE CENTRALE	ZENTRALEINHEIT	CENTRAL UNIT	UNIDAD CENTRAL
3	510587	1	ANTENNA	ANTENNE	ANTENNE	ANTENNA	ANTENA
4	510851	1	UNITA' RICEVENTE	UNITE RECEPTRICE	EMPFANGSEINHEIT	RECEIVER UNIT	UNIDAD RECEPTORA
5	510581	1	CARICABATTERIA	CHARGEUR BATTERIE	BATTERIELADEGERÄT	BATTERY CHARGER	CARGADOR BATERIA
6	510582	1	BATTERIA	BATTERIE	BATTERIE	BATTERY	BATERIA
7	510580	1	CAVO	CABLE	KABEL	CABLE	CABLE
8	510755	1	CINGHIA	COURROIE	RIEMEN	BELT	CORREA
9	510585	1	PULSANTE	BOUTON	TASTE	BUTTON	BOTON
10	510885	1	PULSANTE	BOUTON	TASTE	BUTTON	BOTON
11	510756	1	INTERRUTTORE	INTERRUPTEUR	SCHALTER	SWITCH	INTERRUPTOR
12	510890	1	GANCIO	CROCHET	HAKEN	HOOK	GANCHO
13	510883	1	INTERRUTTORE	INTERRUPTEUR	SCHALTER	SWITCH	INTERRUPTOR
14	510884	1	INTERRUTTORE	INTERRUPTEUR	SCHALTER	SWITCH	INTERRUPTOR
15	510586	1	LEVA	LEVIER	HEBEL	LEVER	PALANCA
16	510857	1	COPERCHIO	COUVERCLE	DECKEL	COVER	TAPA
17	510856	1	TARGHETTA	AUTOCOLLANT	SCHILD	DECAL	ETIQUETA
18	510882	1	COPERCHIO	COUVERCLE	DECKEL	COVER	TAPA
19	510881	1	COPERCHIO	COUVERCLE	DECKEL	COVER	TAPA
20	510850	1	CORPO RADIOCOMANDO	CORPS RADIOCOMMANDE	FUNKSTEUERUNGSGEHÄUSE	RADIO CONTROL BODY	CUERPO RADIOCONTROL
21	510922	1	SCHEDA	FICHE	KARTE	BOARD	ESQUELA
22	510924	1	UNITA' TRASMITTENTE	UNITE EMETTRICE	SENDEREINHEIT	TRANSMITTER UNIT	UNIDAD TRANSMISORA
23	510923	1	UNITA' RICEVENTE	UNITE RECEPTRICE	EMPFANGSEINHEIT	RECEIVER UNIT	UNIDAD RECEPTORA



RADIOCOMANDO HTR 6F CE STD/INV (240247) (23 P)

- * Radiocommande HTR 6F CE STD/INV (240247)
- * Funksteuerung HTR 6F CE STD/INV (240247)
- * Radio control HTR 6F CE STD/INV (240247)
- * Radiocontrol HTR 6F CE STD/INV (240247)

TAV. SY.02.01

matr. G107.0005

21
23 P

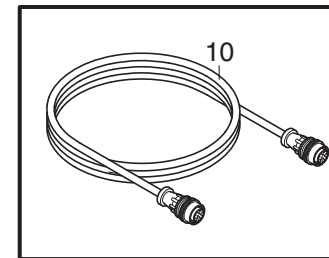
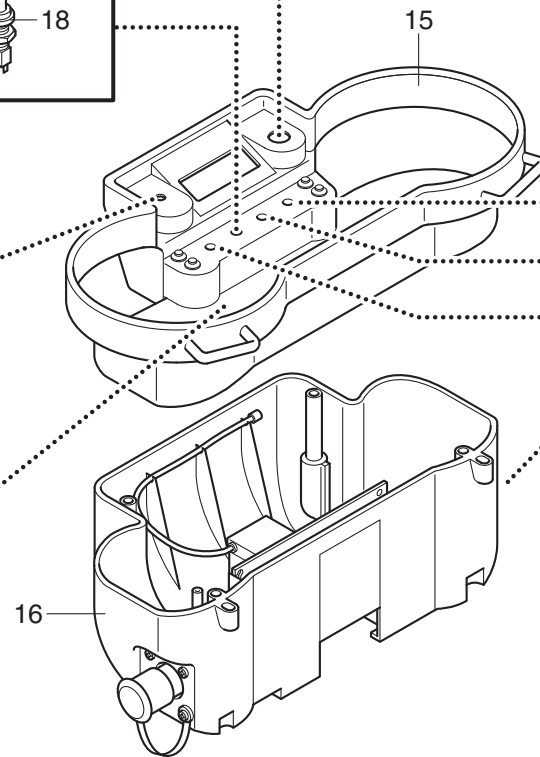
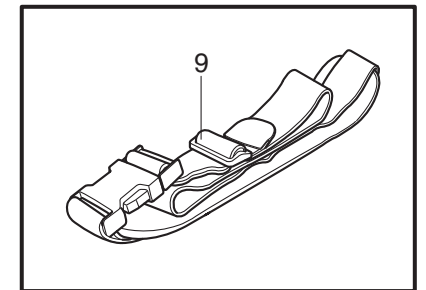
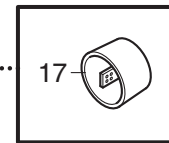
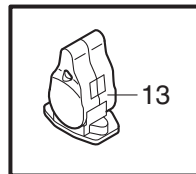
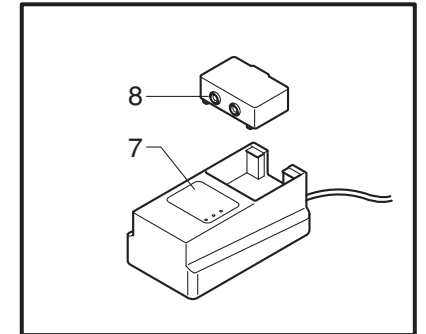
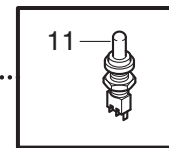
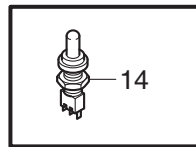
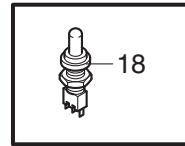
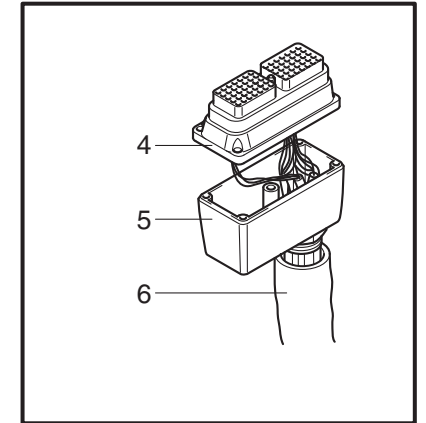
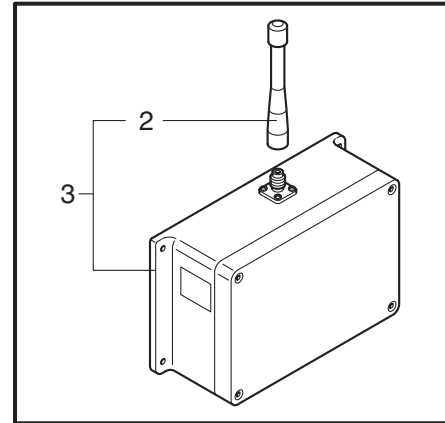
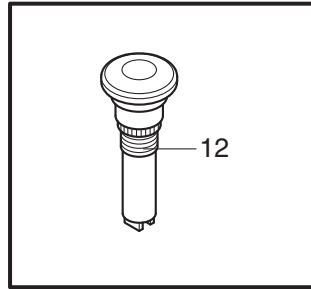
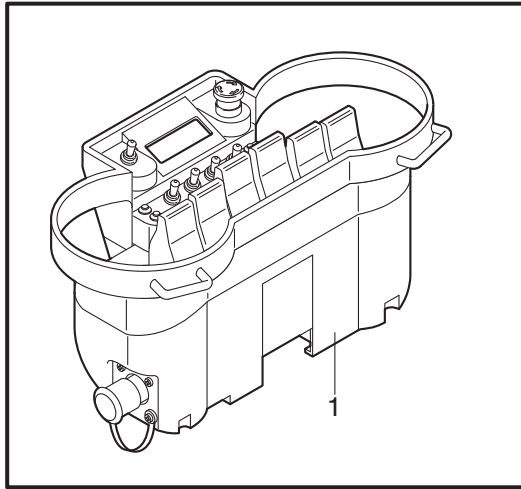

PM 23 P**matr. G107.0005****TAV. SY.02.01**

POS.	N° CODICE	Q.	DESCRIZIONE	DESIGNATION	BENENNUNG	DESCRIPTION	DENOMINACIONES
1	510867	1	UNITA' TRASMITTENTE	UNITE EMETTRICE	SENDEREINHEIT	TRANSMITTER UNIT	UNIDAD TRANSMISORA
2	510913	1	ANTENNA	ANTENNE	ANTENNE	ANTENNA	ANTENA
3	510866	1	UNITA' RICEVENTE	UNITE RECEPTRICE	EMPFANGSEINHEIT	RECEIVER UNIT	UNIDAD RECEPTORA
4	510813	1	CONNETTORE	CONNECTEUR	VERBINDER	CONNECTOR	CONECTOR
5	510814	1	CORPO CONNETTORE	CORPS CONNECTEUR	VERBINDERGEHAUSE	CONNECTOR BODY	CUERPO CONECTOR
6	510868	1	CAVO	CABLE	KABEL	CABLE	CABLE
7	510567	1	CARICABATTERIA	CHARGEUR BATTERIE	BATTERIELADEGERÄT	BATTERY CHARGER	CARGADOR BATERIA
8	510687	1	BATTERIA	BATTERIE	BATTERIE	BATTERY	BATERIA
9	510804	1	CINGHIA	COURROIE	RIEMEN	BELT	CORREA
10	510815	1	CAVO	CABLE	KABEL	CABLE	CABLE
11	510803	1	SELETTORE	SELECTEUR	WAHLSCHALTER	SELECTOR	SELECTOR
12	510552	1	PULSANTE	BOUTON	TASTE	BUTTON	BOTON
13	510739	1	LEVA	LEVIER	HEBEL	LEVER	PALANCA
14	510911	1	SELETTORE	SELECTEUR	WAHLSCHALTER	SELECTOR	SELECTOR
15	510907	1	COPERCHIO	COUVERCLE	DECKEL	COVER	TAPA
16	510908	1	COPERCHIO	COUVERCLE	DECKEL	COVER	TAPA
17	510752	1	CHIAVE	CLE	SCHLÜSSEL	KEY	LLAVE
18	510912	1	SELETTORE	SELECTEUR	WAHLSCHALTER	SELECTOR	SELECTOR



RADIOCOMANDO HTR 6F USA STD/INV (270592) (23 P)

- * Radiocommande HTR 6F USA STD/INV (270592)
- * Funksteuerung HTR 6F USA STD/INV (270592)
- * Radio control HTR 6F USA STD/INV (270592)
- * Radiocontrol HTR 6F USA STD/INV (270592)

TAV. SY.02.02

matr. G107.0005

21
23 P

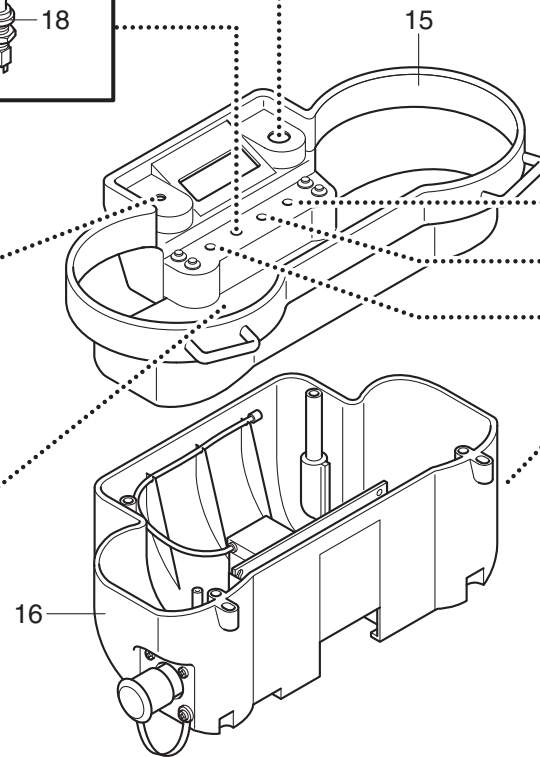
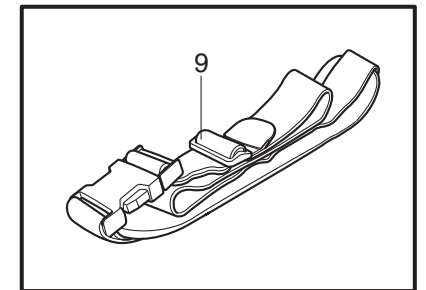
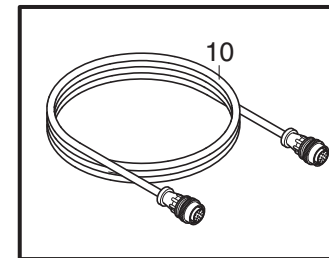
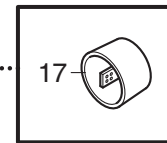
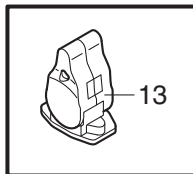
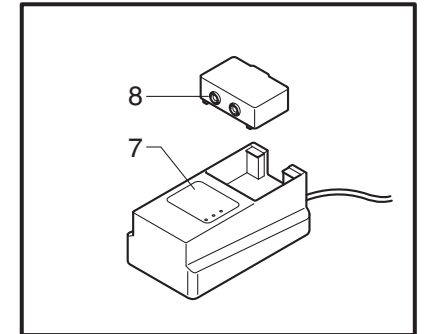
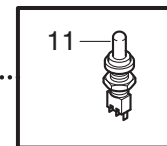
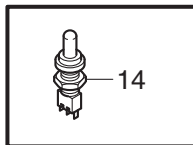
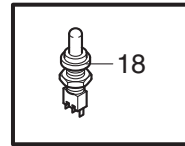
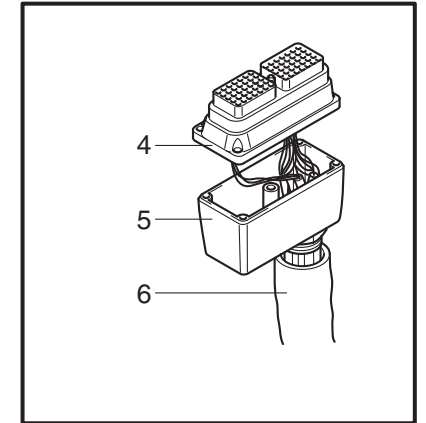
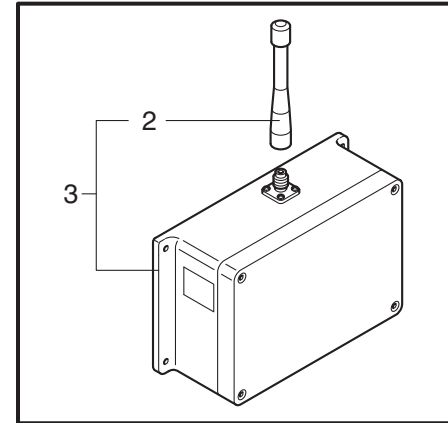
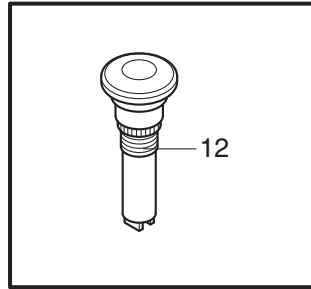
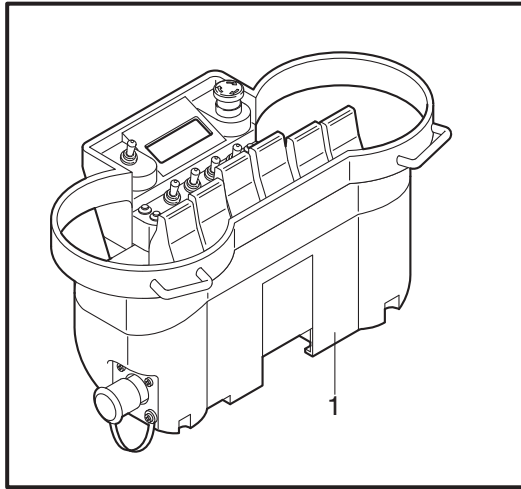

PM 23 P**matr. G107.0005****TAV. SY.02.02**

POS.	N° CODICE	Q.	DESCRIZIONE	DESIGNATION	BENENNUNG	DESCRIPTION	DENOMINACIONES
1	510901	1	UNITA' TRASMITTENTE	UNITE EMETTRICE	SENDEREINHEIT	TRANSMITTER UNIT	UNIDAD TRANSMISORA
2	510913	1	ANTENNA	ANTENNE	ANTENNE	ANTENNA	ANTENA
3	510900	1	UNITA' RICEVENTE	UNITE RECEPTRICE	EMPFANGSEINHEIT	RECEIVER UNIT	UNIDAD RECEPTORA
4	510813	1	CONNETTORE	CONNECTEUR	VERBINDER	CONNECTOR	CONECTOR
5	510814	1	CORPO CONNETTORE	CORPS CONNECTEUR	VERBINDERGEHAUSE	CONNECTOR BODY	CUERPO CONECTOR
6	510902	1	CAVO	CABLE	KABEL	CABLE	CABLE
7	510567	1	CARICABATTERIA	CHARGEUR BATTERIE	BATTERIELADEGERÄT	BATTERY CHARGER	CARGADOR BATERIA
8	510687	1	BATTERIA	BATTERIE	BATTERIE	BATTERY	BATERIA
9	510804	1	CINGHIA	COURROIE	RIEMEN	BELT	CORREA
10	510815	1	CAVO	CABLE	KABEL	CABLE	CABLE
11	510803	1	SELETTORE	SELECTEUR	WAHLSCHALTER	SELECTOR	SELECTOR
12	510552	1	PULSANTE	BOUTON	TASTE	BUTTON	BOTON
13	510739	1	LEVA	LEVIER	HEBEL	LEVER	PALANCA
14	510911	1	SELETTORE	SELECTEUR	WAHLSCHALTER	SELECTOR	SELECTOR
15	510907	1	COPERCHIO	COUVERCLE	DECKEL	COVER	TAPA
16	510908	1	COPERCHIO	COUVERCLE	DECKEL	COVER	TAPA
17	510752	1	CHIAVE	CLE	SCHLÜSSEL	KEY	LLAVE
18	510912	1	SELETTORE	SELECTEUR	WAHLSCHALTER	SELECTOR	SELECTOR

